

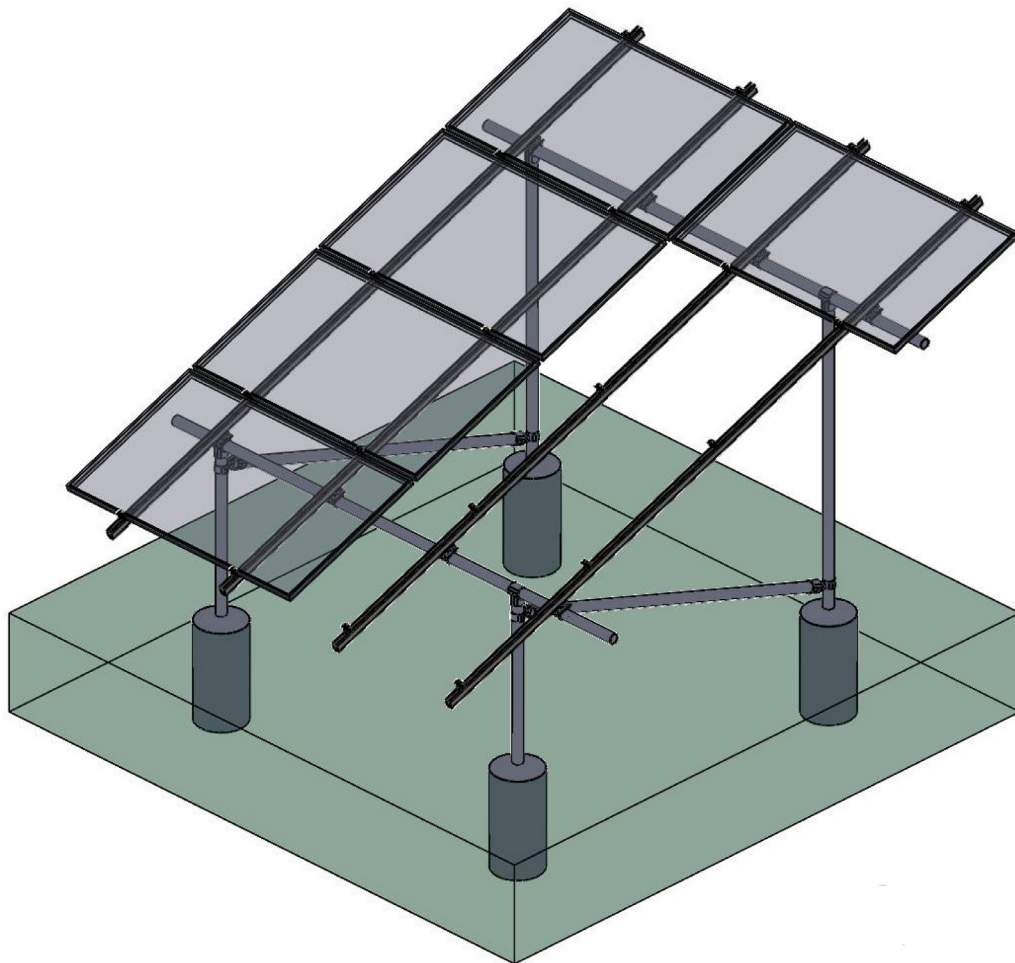

# Tamarack Ground Mount System Installation Manual



## Table of Contents

Product Summary . . . . .	3
Installer Responsibilities . . . . .	4
System Components . . . . .	5
Tools Required and Torque Specifications . . . . .	6
System Design . . . . .	7
Foundation Layout . . . . .	7 - 9
Assemble Pipe Structure. . . . .	10 - 12
Install Module Support Rails . . . . .	13 - 14
Module Level Electronics and Wire Management . . . . .	14
Grounding. . . . .	15
Module Installation . . . . .	16 - 17
Certified Module List for use with Tamarack Rail and Fittings . . . . .	18 - 19

## Customer Support

Tamarack Solar makes every effort to ensure your mounting kit is easy to install. If you need assistance at any point in your installation or have suggestions on how we can improve your experience, call customer support at 1-800-819-7236 ext 556 or email us at support@tamaracksolar.com

**Technical Support:** Call 707-234-8107 or email us at support@tamaracksolar.com

## Warranty Information

Warranty details can be found on our website: [www.tamaracksolar.com/warranty/](http://www.tamaracksolar.com/warranty/)

## Disclaimer

This manual describes proper installation procedures and provides necessary standards required for product reliability. All installers must thoroughly read this manual and have a clear understanding of the installation procedures prior to installation. Failure to follow these guidelines may result in property damage, bodily injury or even death.

## Tamarack Ground Mount System Features

- Designed for mounting photovoltaic (PV) arrays on the ground.
- Only 4 tools required for installation
- Top clamps and rail attachments require the use of a 1/2-IN socket
- One part for both mid-clamp and end-clamp use simplifies ordering and stocking parts
- Module clamps are spring loaded to ease module placement
- Built-in wire management for module and microinverter cables

## Tamarack Product Summary

The Tamarack Solar Ground Mount system is a visually appealing photovoltaic (PV) module installation system that significantly lowers PV module installation cost by allowing the installation professional to stock fewer parts and to complete the installation in less time. Certified to meet local and International Building Codes and ASCE/SEI-7 when installed in accordance with this manual.

ETL Listed to UL 2307 for bonding and grounding when installed in accordance with this manual.

Rails, clamps, splices, and mounting devices are UL2703 Listed for mounting flat-plate Photovoltaic Modules and Panels

- Conforms to STD UL 2703 (2015) Standard for Safety First Edition: Mounting Systems, Mounting Devices, Clamping/Retention Devices, and Ground Lugs for Use with Flat-Plate Photovoltaic Modules and Panels.
- Certified to CSA STD LTR AE-001-2012 Photovoltaic Module Racking Systems.
- Max Overcurrent Protective Device (OCPD) Rating: 20A
- Max Module Size: 25.6 ft<sup>2</sup>
- System Level Allowable Design Load Rating: meets minimum requirements of the standard (10 PSF downward, 5 PSF upward, 5 PSF lateral). Actual system structural capacity is defined by PE stamped certification letters.



## Installer Responsibilities

- Comply with all applicable local or national building codes, including any that may supersede this manual.
- Ensure all products used are appropriate for the particular installation and the installation environment including the site's loading conditions. Parameters, such as snow loading, wind speed, exposure and topographic factor should be confirmed with the local building official or a licensed professional engineer.
- Use only Tamarack Solar parts or parts approved by Tamarack Solar; substituting parts may void any applicable warranty.
- Ensure safe installation of all electrical aspects of the PV array. Electrical installation should be conducted by a licensed and bonded electrician or solar contractor.
- If loose components or loose fasteners are found during periodic inspection, retighten immediately. If corrosion is found, replace affected components immediately.
- Review module manufacturer's documentation to ensure compatibility and compliance with warranty terms and conditions.
- Maximum Series Fuse Rating for the photovoltaic array is 30 Amps.
- Ensure bare copper grounding wire does not contact aluminum and zinc-plated steel components, to prevent risk of galvanic corrosion.
- Ensure information used for the system design is accurate. Any inaccurate information used for the system design will cause errors and are the installer's responsibility to correct.
- Provide an appropriate method of direct-to-earth grounding according to the latest edition of the National Electrical Code, including NEC 250: Grounding and Bonding, NEC 690: Solar Photovoltaic Systems, and CSA C22.1, Safety Standard for Electrical Installations, Canadian Electrical Code, Part 1
- Disconnect AC power before servicing or removing microinverters and power optimizers.
- Module maintenance or removal must not break the bonding path of the system.

For Technical Support, call 707-234-8107 or 800-819-7236 ext.556 or email us at [support@tamaracksolar.com](mailto:support@tamaracksolar.com).

# Tamarack Ground Mount System Components

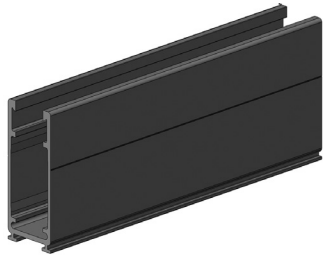

### 3.1 inch Mill Finish Rail

Our 3.1-inch heavy duty rail provides great performance with extreme wind and snow loads.

#90910 - 70-IN - 8-Rail Pack

#90927 - 70-IN - 144-Rail Pallet

#90545 - 93-IN - 8-Rail Pack

#90552 - 93-IN - 144-Rail Pallet

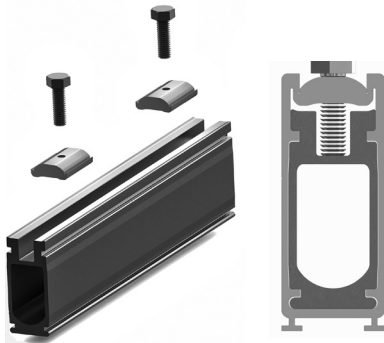

### 3.1 Structural Rail Splice

Quickly splice and bond 3.1-inch rail sections. Top Clamps can be co-located with splice. Wires and connectors can be run through opening.

#89556 - Splice w/channel nuts and bolts 6-Pack

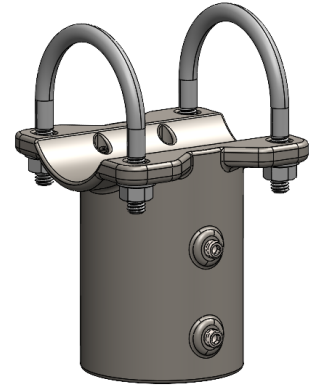

### Pole Cap

Connect vertical pipe to horizontal pipe. U-bolts are included.

For 2-IN post: #90682 2-Pack

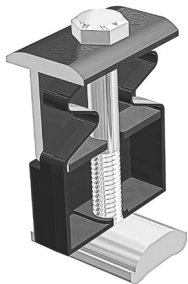

### 5050 Clamp

One clamp can be used as a mid-clamp or an end-clamp on modules with 30 mm to 40 mm frame height.

#88450 12-Pack

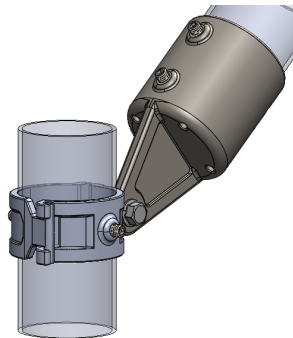

### Swivel Tee Fitting

Use for wind cross-bracing front to back vertical posts.

For 2-IN post: #90699

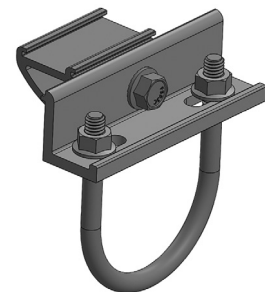

### Pipe Mount

Securely mount the rail to the horizontal pipe. U-bolts are included.

For 2-IN pipe: #88955 8-Pack



### Wire Clip

Pushes into top of rail to keep cables in place.

#88474 24-Pack



### Rail Ground Lug

Use one per module column to ground rail with bare 6 to 10 AWG copper wire.

#88504 8-Pack

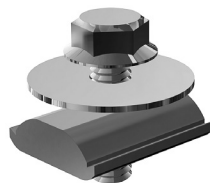

### MLPE Adapter

Use for mounting micro-inverters and optimizers on the rails under the solar modules.

#88481 12-Pack



### Module Frame Ground Lug

#89013 10-Pack



### Rail End Cap

Gives the installation a finished look and keeps insects from nesting in the rails.

#89846 8-Pack

## Tools Required

- Post Hole Digger or Power Auger
- Cordless Drill
- Torque Wrench
- 1/4-IN Hex Key Socket
- 1/2-IN socket and ratchet
- 3/16-IN Hex Driver Socket
- String Line and Level or Transit
- Tape Measure
- Chop saw or band saw to cut rails (optional)
- Pipe Cutter

## Torque Specifications

Rail Adapter on Pipe Mount Clamp . . . . .	144 in-lbs (12 ft-lbs)
U-Bolt Nuts on Pipe Mount Clamp . . . . .	72 in-lbs (6 ft-lbs)
Swivel Socket Tees . . . . .	204 in-lbs (17 ft-lbs)
Pole Cap - U-bolts . . . . .	144 in-lbs (12 ft-lbs)
Pole Cap - Set Screws . . . . .	204 in-lbs (17 ft-lbs)
Rail Splice Lock bolts . . . . .	144 in-lbs (12 ft-lbs)
MLPE Mount (optional part, not included in kits) . . . . .	144 in-lbs (12 ft-lbs)
Ground Lug . . . . .	144 in-lbs (12 ft-lbs)
5050 Clamp as Mid-Clamp. . . . .	144 in-lbs (12 ft-lbs)
5050 Clamp as End Clamp. . . . .	72-108 in-lbs (6-9 ft-lbs)
Ground Lug . . . . .	144 in-lbs (12 ft-lbs)
Ilsco SGB-4 Module Frame Ground lug (optional part, not included in kits) . . . . .	144 in-lbs (12 ft-lbs)

## Prepare for Installation

Plan the PV module layout and confirm that plans comply with local AHJ requirements.

Leave enough room to work safely around the array during the installation process. Some building and fire codes require minimum clearances around PV module installations.

The length of the rails for each row in the installation will be equal to the total width of the modules plus 1/2-IN for each 5050 clamp used between modules plus 2-IN total for end clamping.

Purchase 2-IN (NPS) ASTM A53 Grade B Schedule 40 Pipe, galvanized to a min of ASTM A653 G90 or ASTM A123 G35, or 2.375-IN (O.D.) Allied Mechanical Tubing with Gatorshield or FlowCoat Zinc Coating (ASTM A1057)

Verify Module Compatability with the Tamarack Rail System. See Page 18-19 for information.

## System Design

Make a drawing showing the dimensions of the mount system and the location of the mounting piers. Use the Tamarack state specific engineering letter or contact Tamarack Technical Support for design information. Documentation can be found at <https://tamaracksolar.com/downloads/#ground-mount>.

Tamarack design information assumes that the array is on relatively flat ground with no more than 15 degrees of slope.

Tamarack engineering data is for use in sites with Class 3 or Class 4 soil type and terrain exposure category B, C or D. If terrain and/or soils conditions are different consult a structural engineer.

Class 3 Soil Medium dense coarse sands, sandy gravels, very stiff silts and clays.

Class 4 Soil Loose to medium dense sands, firm to stiff clays and silts, alluvial fill.

Exposure Category B - Urban and suburban and wooded areas filled with obstructions the size of single family dwellings must surround the structure at least 2,630 ft or 10 times the structure height in all directions whichever is greater.

Exposure Category C - Open terrain with scattered obstructions having heights generally less than 30 ft [9.1 m]. This category includes flat, open country, grasslands and shorelines in hurricane regions.

Exposure Category D - Flat, unobstructed shorelines exposed to wind flowing over open water (excluding shorelines in hurricane prone regions) for a distance of at least 1 mile [1.61 km]. Shorelines in Exposure D include inland waterways, lakes and non-hurricane coastal areas. Exposure D extends inland a distance of 660 ft [200 m] or ten times the height of the structure, whichever is greater. Smooth mud flats, salt flats and other similar terrain shall be considered as Exposure D.

## Foundation Hole and Post Layout

The Tamarack Ground Mount System allows for two potential design configurations. Modules are mounted in landscape (long side of the modules oriented towards top and bottom edges of mount). Standard configurations can be either three or four modules per column in landscape orientation.

North to South post spacing is always constant and depends on the design choice for the number of modules in each column. North/south post spacing is 72" for systems with columns of 3 modules and north/south spacing is 90" for columns of 4 modules.

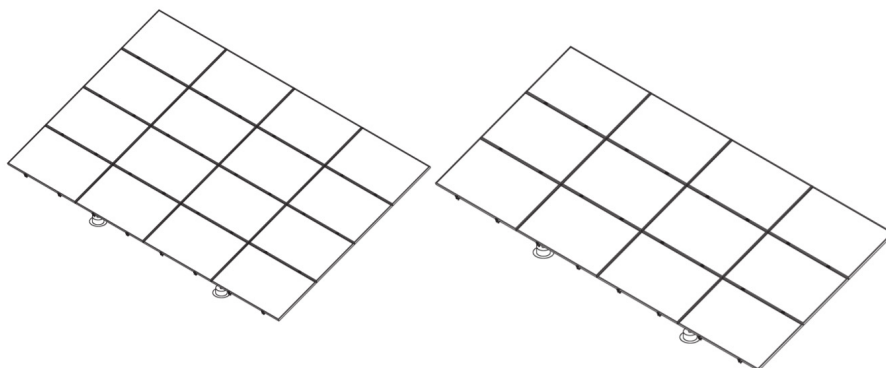

Find the maximum allowable East to West post spacing, based on the maximum allowable span between vertical posts from the online configuration tool or from the engineering letters. Do not exceed maximum allowable spacing, however you can use a closer spacing if that works out better with the particular horizontal pipe length for your array's length.

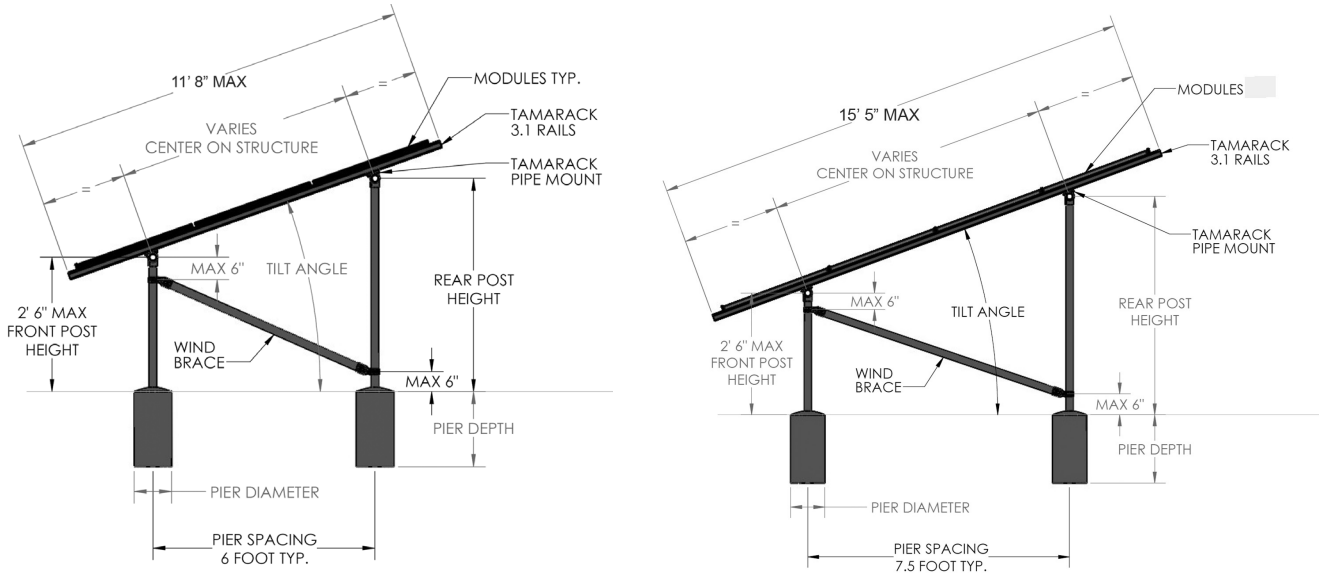

There will be two potential east-west post spacing distances: one with front to rear cross bracing and one without. Without cross bracing, post spacing will be less, typically requiring more vertical posts and piers. In some wind and snow load situations, only a braced configuration may be usable. Choose the design you plan to use.

NOTE: The maximum east/west length of the array should not exceed 100 feet in order to minimize the effects of expansion and contraction of the steel pipe structure. If the total array length will exceed 100 feet, break up the array into two or more separate and unconnected sections.

Place the footing locations so that the spacing is no greater than the maximum spacing in the engineering document applicable for the details of your installation. The horizontal pipe can cantilever past the end posts up to 0.4 times the maximum allowable span. For example: if the maximum allowable east to west pier spacing is 60-IN, the end cantilever can be up to 24-IN.

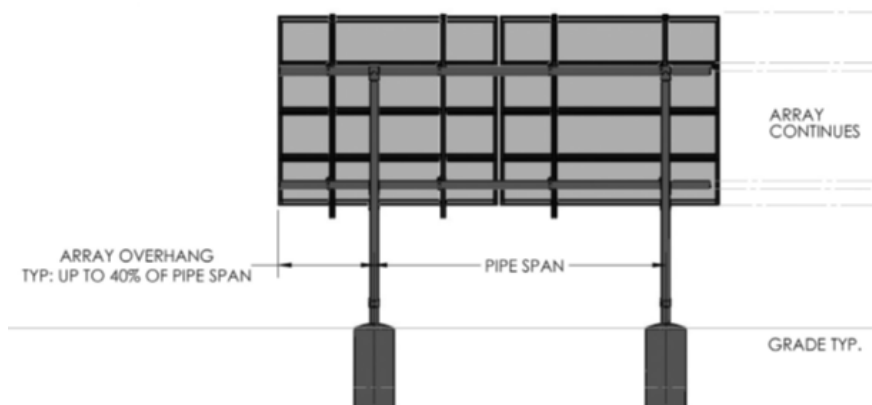

Using batter boards and string lines, lay out your footing locations for both the front and back east-west rows of piers. This will consist of two string lines, one for the front east-west row of piers and one for the back row of piers. Be sure that the two strings are parallel to each other, and with the proper spacing between the two east-west rows (this spacing depends on whether you use columns of 3 or 4 modules - (see page 7).

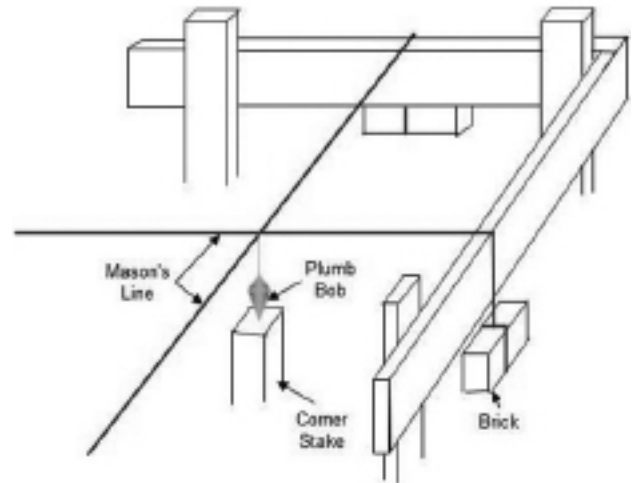
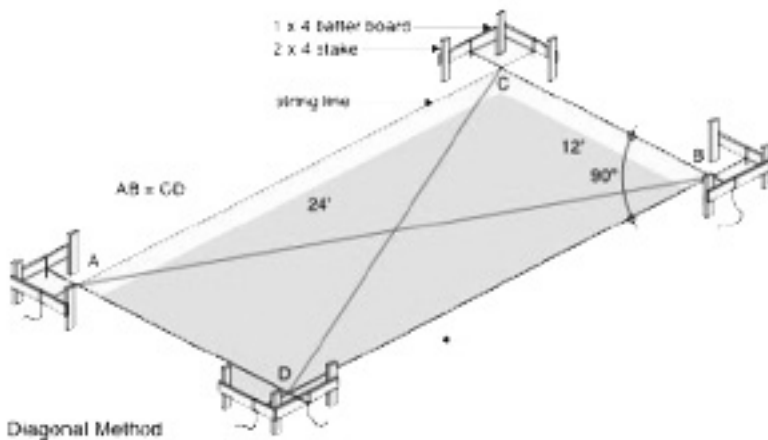

Once you have the two east-west string lines properly in place, place the first north-south string across one end, at the location where you want the first piers to be located. The first two piers (front and back) will be located directly below where the north-south string and two east-west strings cross.

Continue to add batter boards and north-south strings, spaced apart according to the proper east-west pier spacing. If you only need four piers (two front and two rear), you will only need two north-south strings. If you need six piers total, you will need three north-south strings. Eight piers would require four strings, etc. Make sure that the strings are in the proper locations and adjust as needed. Make sure that the whole layout is square and aligned evenly.

Directly below where each north-south string crosses one of the east-west strings will be the location of the center of a foundation hole and pier. Use a plumb bob to locate those points on the ground and drive a stake at each location. These are the centers of where the holes will be excavated. Once the stakes are driven, the strings may be temporarily removed.

## Excavating Holes for Concrete Piers

Hole depth for the piers is specified in the engineering document. The diameter and depth are related. A larger hole diameter allows the hole to be less deep. The vertical post must extend  $\frac{2}{3}$  of the distance from the ground to the bottom of the hole.

Using a power auger with the appropriate diameter auger, excavate footings at marked locations to the depth required by the structural engineering. Re-install the layout strings to make sure that the holes are excavated at the proper locations and adjust the hole centers if necessary. Clean out as much loose soil as you can from the augured holes.

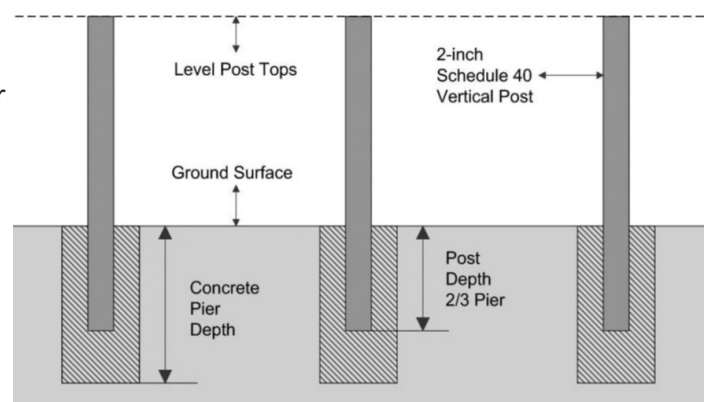

## Assemble Pipe Structure

While there are a number of methods that can be used to set the vertical pipe posts in concrete, we recommend the following method which makes it easier to align and level the pipe sub-structure:

Using the Pole Caps for 2-IN posts and sections of 2-IN pipe, assemble both the front and back 2-IN pipe horizontal beams, placing the Pole Caps at the proper distance apart based on the required pier spacing. Tighten the Pole Cap U-bolts just enough to hold them in place, but not fully tightened as their location may need to be adjusted later. Leave the horizontal pipe longer than necessary until the rails are assembled. This will allow for some adjustment from side to side.

**NOTE: Schedule-40 steel pipe is available in lengths up to 21 feet. For arrays with more than 3 or 4 columns, you may need to splice two sections of pipe together. Couplings are not permitted in the end cantilever section, in the outer 2/3 of an end span or in the middle 2/3 of an interior span. You can splice pipe sections in the center of a Pole Cap, or by using a 2-IN threaded pipe coupling or our 90705 Pipe Coupler, which can be used on pipe that is not threaded. If splicing pipes over a Pole Cap, pipe ends must have less than 1/2-IN between pipe ends.**

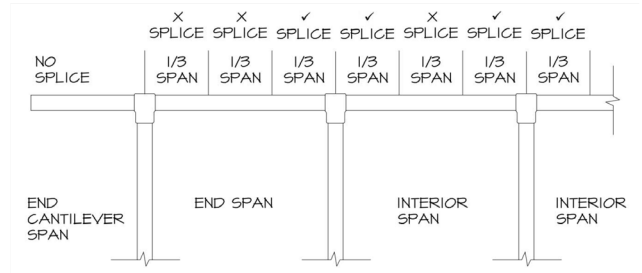

The height of the north (rear) posts will be determined by the tilt angle of the array. Use Tamarack Solar's online Ground Mount Configurator to determine the lengths of the post pipes needed. If the ground is sloped to the south, subtract the ground height difference of the rear pier location from the front pier location to determine how much the rear post lengths need to be shortened. Front post are always 30-IN above ground level.

North/south post spacing is 72-IN for systems with columns of 3 modules and north/south spacing is 90-IN for columns of 4 modules. Support the horizontal pipe beams at the proper height above the ground level using X-brace pipe supports made with 2x4 or 2x6 wood boards (or use commercially available pipe supports). Center the Pole Caps on the 2-IN pipe directly above the excavated holes. The X-braces can each be made using two boards with holes drilled at the proper location, and a connected together with a single bolt and nut to act as a hinge.

Level the two horizontal beams, and make sure that they are straight and parallel with each other and at the proper distance apart. The two boards of each X-brace can be pulled closer together at the bottom to raise the beam or drawn further apart to lower the beam to achieve level. Hold the X-braces in place with another board going down to the ground set at 90° to the X-braces as shown in the photos. Fine adjustment to level can also be done using shims between the beam pipes and the X-Braces. If the horizontal beams are long, you can do this in sections for easier handling. Check for array tilt consistency along the entire length of array and adjust if necessary. Use stakes at the bases of the brace boards to hold them in place. Steel concrete form stakes are perfect for this purpose, but you can also use wooden stakes.

As the tops of the concrete piers need to be above ground level to keep water from pooling around the pipe posts,

To keep water from pooling around the vertical pipes you can trowel a dome of concrete above ground level or use a 6-IN piece of 12" diameter Sonotube to form a



pedestal above the in-ground section of the concrete piers. It is only necessary for the tubes to be located from the ground level up. If you use the tube form, you will need to hang these Sonotube sections from the horizontal beams at each vertical post location before installing the pipe posts into the assembly. They will need to remain suspended until the concrete is poured, and then placed into position during the concrete pour. The pipe posts need to go through the center of each Sonotube piece so that when lowered, the pipe post is in the center of the Sonotube.

Next, hang the pipe posts from the Pole Caps. Insert each of the pipe posts down into each hole, at each of the post locations, and lift them up through the suspended Sonotube rings and into the bottom parts of the Pole Cap. Make sure that each post is fully inserted into each Pole Cap. Try not to allow the posts to contact the soil on the sides or bottom of the holes. If they do, do not allow any soil material to remain on or inside the pipes. Tighten the set screws on Pole Caps just enough to hold the post pipes in place. Ensure that the bottom of each post pipe extends 2/3 of the way to the bottom of the hole. Shorten the post pipes, or use a longer pipe section, if necessary. Then tighten the Pole Cap set screws on the post pipe to make sure that they stay in place.

Make any adjustments to the Pole Caps required to center the pipe posts in the holes. Do a final check to make sure that the horizontal beams are level and properly located at the correct spacing between each other, and that the posts are plumb and centered in the holes.

## Pouring Concrete

Pour mixed concrete (minimum 2500 psi) into excavated holes. Use a tamping tool (a length of 2x4 works well) to compress the wet concrete to make sure that there are not any trapped air pockets. As you are filling the hole with concrete make sure that the vertical post remains centered and plumb.

Fill the holes to ground level, and then lower the previously hung Sonotube sections down onto the wet concrete, with the pipe posts centered. Twist or shake the Sonotube to make sure it is in full contact with the wet concrete. You may want to make up a measuring jig beforehand to that you can position all of the Sonotubes at the same height above ground for aesthetic reasons. Use a short level to make sure that the sides of the Sonotubes are plumb and fill the tubes with concrete. Trowel the tops of the concrete into a slight dome formation to allow for water drainage.

Allow the concrete to cure for at least 24 hours before proceeding.



## System With Cross Braces

**Skip this step if cross bracing is not required.**

On each north/south post pair, attach a Swivel Tee Fitting to each vertical pipe.

Slide the Swivel Tee on the rear (north) post all the way to the bottom to the cured concrete and slide the one on the front (south) post to near the top of the post and set it at about 1/2-IN below the bottom of the Pole Cap containing the front horizontal beam pipe (this will allow space as you insert the brace pipes).

Face and align the two Swivel Tee sockets towards each other – the socket on the raised south Swivel Tee facing down towards the Swivel Tee on the lowered north post. Tighten the set screws just enough to hold both Swivel Tees in place.

Measure the length of pipe needed to be the brace pipe. The pipe ends can be inserted 2 inches into each Swivel Tee, but in order to insert the pipe into both Tees, the pipe will need to be cut shorter. Measure from the very inside of one of the Swivel Tees to the outside edge of the other Swivel Tee. Cut the pipe for the brace to this length.

To assemble the brace, first loosen the set screws on Swivel Tee at the bottom of the north post. Slide one end of the brace pipe fully into this Swivel Tee socket until it bottoms out, and tighten the set screw on the brace pipe, but do not tighten the set screws on the post pipe yet.

Angle the brace pipe up toward the Swivel Tee on the south post. After loosening the set screws on this Swivel Tee, guide the end of the pipe into the socket and lower the Swivel Tee assembly down until the pipe end is fully inserted into the socket and tighten the set screw onto the brace pipe.

With the set screws on both of the Swivel Tees that attach to the vertical posts loose, slide the whole brace assembly up so that there is roughly the same amount of space between the Swivel Tee on north post and the top of the concrete, and between the top of the Swivel Tee and the bottom of the Pole Cap on the south post. Make sure that there is no more than 6-IN from the center of the north-post Swivel Tee to the surface of the concrete, and no more than 6-IN from the center of the south horizontal beam and the center of the Swivel Tee on the south post, as the drawing on the right shows.

Repeat this whole process for installing the cross braces on each north/south pair of posts. There may need to be changes to the lengths of the brace pipes from location to location, especially if the installation site is not completely level.

## Assemble Module Support Rails

If you are installing **4 modules per column**, use two 93-IN rail sections to make each 186-IN rail.

You will need two of the 186-IN rails per column. The maximum module width that can be accommodated on this rail length is 45-IN per module.

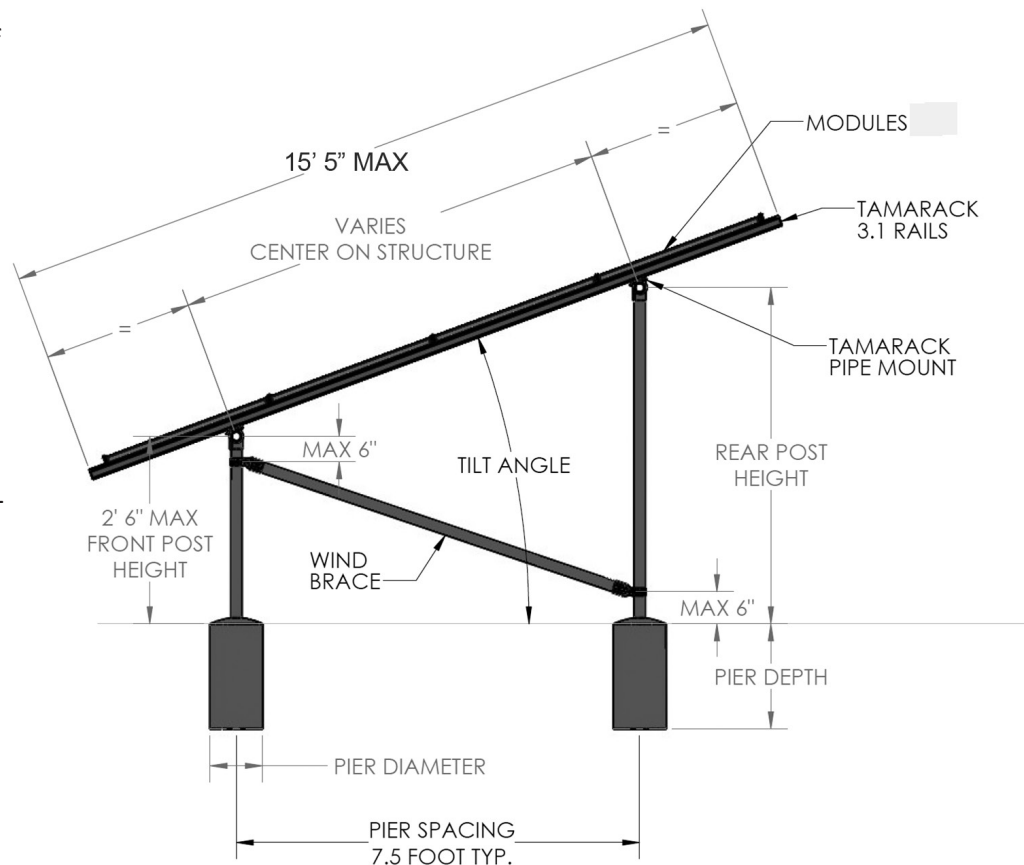
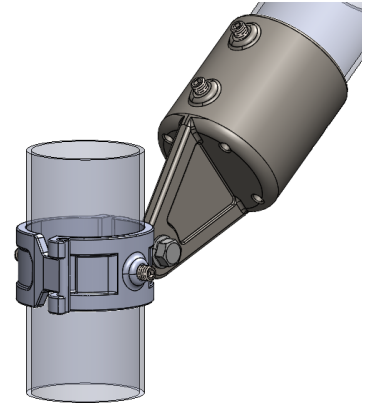

If you are installing **3 modules per column**, use two 70-IN rail sections to make each 140-IN Module Support Rail. You will need two of the 140-IN rails per column. The maximum module width that can be accommodated on this rail length is 46.16-IN per module.

The 3.1 Rail Splice comes with two two channel nuts that allow the splice to be clamped in place. Insert the Rail Splice 5-IN into one rail end. Install one bolt and channel nut (roughly centered in the 5-IN insertion) and tighten to hold it in place. Slide the second section of rail over the splice until it contacts the first section of rail and install the second bolt and channel nut. Tighten both bolts to 144 inch-pounds (12 foot-pounds). Either locking bolt may be loosened and moved slightly if it interferes with mid-clamp placement when installing modules. Splices should not be used in a cantilevered section of rail.

Use a Tamarack splice to connect each section of rail in a row.

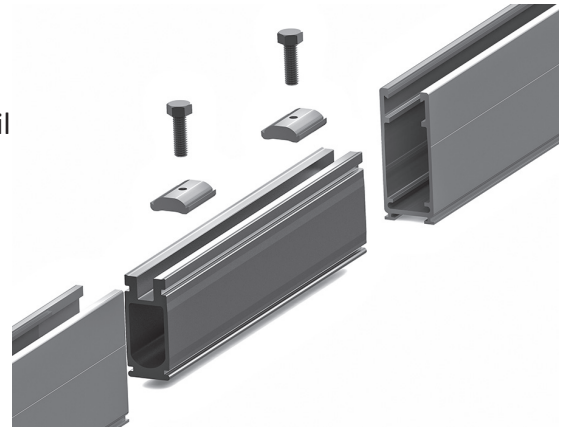

## Attach Mounts

Each Pipe Mount Clamp consists of a rail clamp loosely bolted to an aluminum extrusion and a u-bolt with hardware.

Simply position the adapter into the two feet on the bottom of the rail, and finger tighten the bolt. Leave the bolt slightly loose to allow for repositioning. See picture at right. Finger tighten the flange bolt so that the Pipe Mount Clamps are centered over the cross pipes to match pier spacing, leaving equal distance on ends.

Attach Pipe Mount Clamps to all of the rails at this time.

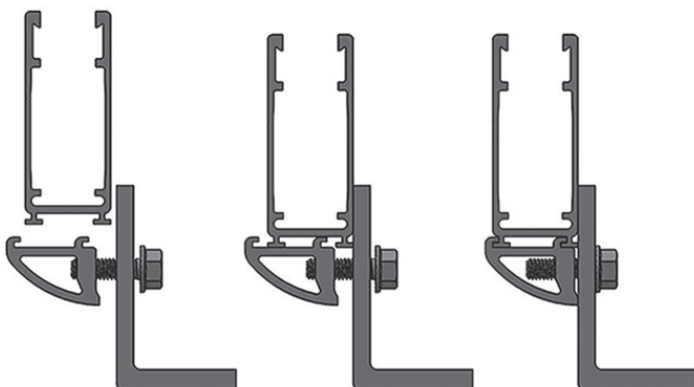
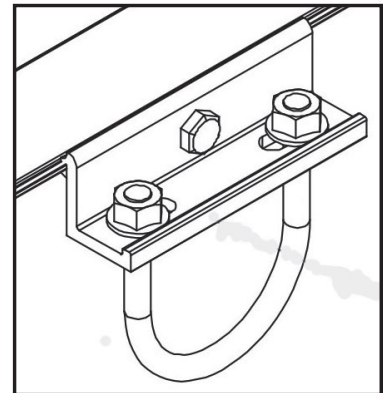

## Install Rail Assemblies onto the Pipe Substructure

Install the first module mounting rail assembly at one end of the horizontal beams at least 1-IN in from the end of the two beams. Position the rail assembly to be centered on the two horizontal beams (north to south), and with the rail assembly perpendicular (90°) to the beams. Finger-tighten the flange nuts on the Pipe Mount Clamps and on the U-bolts.

Locate the second rail on the beams, parallel to the first rail, and attach with the U-bolts provided, and the nuts finger-tight. The spacing between the two rails should align with the module manufacturer's recommended clamping locations on the module frames. This is typically the distance

between the mounting holes on the bottom of the module frames. Align the bottom end of the second rail with the first rail's bottom end so that they are even with each other. You will need to loosen the Pipe Mount Clamp flange nuts in order to slide the rail up or down for alignment. Tighten the U-bolt nuts to 6 foot-pounds and the flange bolts 12 foot-pounds on both rail assemblies. Allow for 1/2-IN between columns.



## Module Level Power Electronics

If you are using rail mounted Module Level Power Electronics (MLPE), install it before installing the solar modules. Use the Tamarack MLPE Rail Adapter to attach Enphase microinverters or SolarEdge Optimizers to the rails. Tighten the bolt with a 1/2" socket to the proper torque.



## Wire Management

Place electrical conductors and connectors at the bottom of the rail channels. Wires can be threaded through the hole in the splices. Install the Module Lead Clips where necessary to keep wires in the channels. If you are using MLPE, use these clips to keep the MLPE wiring in place as it is laid into the rail channels. On a ground mount installation, these clips can be installed from behind the array as necessary to keep wires in place.



# Grounding Diagram

Tamarack rails and PV modules are bonded by 5050 Module Clamps and Rail Splices. Use one Ground Lug per array. Column to Column Bonding is achieved through the Pipe Mounts that connect each rail to the horizontal 2-IN galvanized pipe.

The 5050 clamps achieve bonding to the module frames by stainless-steel pins in the clamping surface of the clamp tops, which penetrate module frame coatings. The rails and channel nuts are bonded because of the conductive surface of the mill finish aluminum used in the rail construction. SolarEdge Optimizers and Enphase Microinverters are bonded to the rail with the Tamarack MPLE adapters.

If modules being used are not on the approved list of modules on page 18 and 19, Module Frame Ground Lugs can be used. One lug is required on each module and a continuous copper wire must be run to each lug and to Rail Ground Lug on one of the module rails.

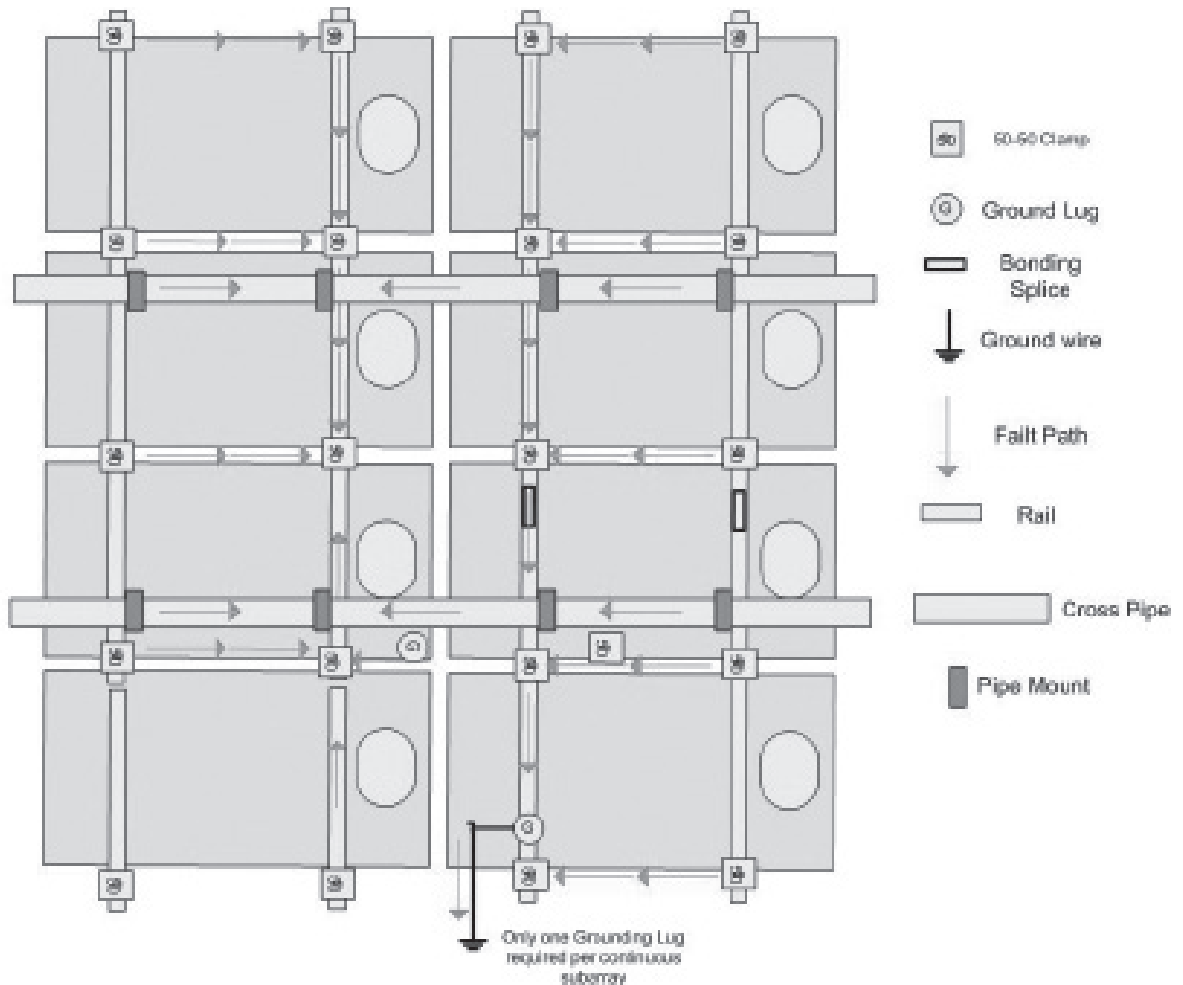
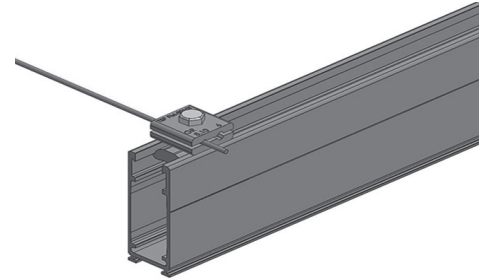

## PV Module Installation

Start module installation at the bottom of the first column. In order to center the column of modules, you will need to determine if, and by how much, the mounting rails will extend past the bottom module and above the top module in the column. This will be determined by the actual width of the particular PV module being used, the number of modules per column, and the 1/2 inch spacing between the modules for the mid-clamps. If installing columns of 3 modules, the rail lengths will be 140 inches. If installing columns of 4 modules, the rail lengths will be 186 inches.

To determine the actual full length of the module column:

For 3-module columns:  $140 - (3 \times \text{module width} + 1 \text{ inch})$

For 4-module columns:  $186 - (4 \times \text{module width} + 1.5 \text{ inch})$

The additional 1 or 1.5 inches in the formulas account for the space required for the 5050 Clamps between the modules.

For example: a 4-column installation with PV module measuring 44 inches in width:

$$186'' - ((4 \times 44'') + 1.5'') \text{ or } 186'' - 177.5'' = 8.5 \text{ inches of extra rail length.}$$

To center the column of modules on the rails, take that measurement of extra rail length and divide by 2. In the example above, that would be 4.25 inches of rail that would extend past the bottom module and past top module in the column.

Place a solar module on the first set of rails so that it is the calculated distance from the lower end of the rails and secure it in place with a 5050 clamp on each rail. Since these clamps will be used as end clamps, place the side of the top clamp with two pins toward the modules. Center the first module east to west over the rails and hold in place. Make sure that the module is straight and level on the rails and tighten the two end clamp bolts to 96 inch-pounds (8 foot-pounds).

Install one 5050 Clamp in each rail on the other side of the first module and slide it down so that the inside of the clamp contacts the frame of the first module. The springs will hold the clamps in place prior to tightening. Place the second module on the rails, align it with the first module, and slide down and fully into the two mid-clamps. Tighten the mid-clamp bolts to 144 inch-pounds (12 foot-pounds) to fully secure the module. Install the third module (and fourth module if installing columns of four) and mid-clamps on the rails in the column in the same manner, aligning the corners of the modules as you go up the column. Check to make sure that the modules in this first column are all even and straight, and where you want them to be.

On the top edge of the last module of the first column, install the 5050 Clamps so that the sides with the two stainless-steel pins are facing in toward the module frame, and the clamp is tight up against the module frame. Tighten the two end clamp bolts 6 foot-pounds.

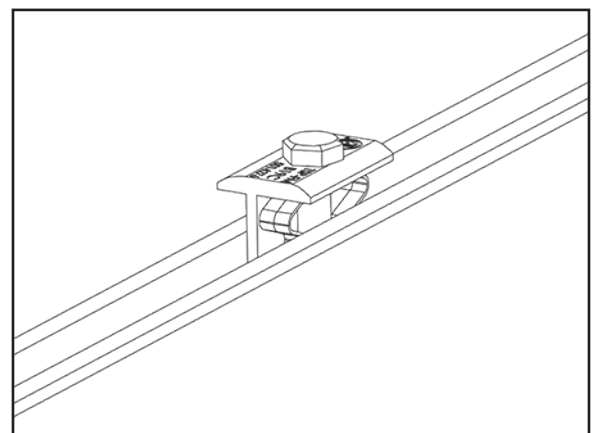
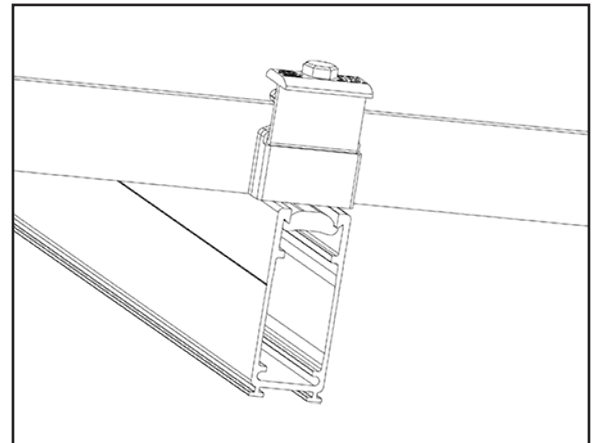

Install subsequent columns of modules in the same manner. Leave 1/2-IN of spacing between the columns. Make sure that all of the rails are centered between the north and south beams and extend past the south beam the same distance at the bottom end. Use a string line as an alignment aid, or just do this with line-of-sight

Do a final check to be sure that all bolts and installation hardware on the array is properly tightened to the specified torque values.

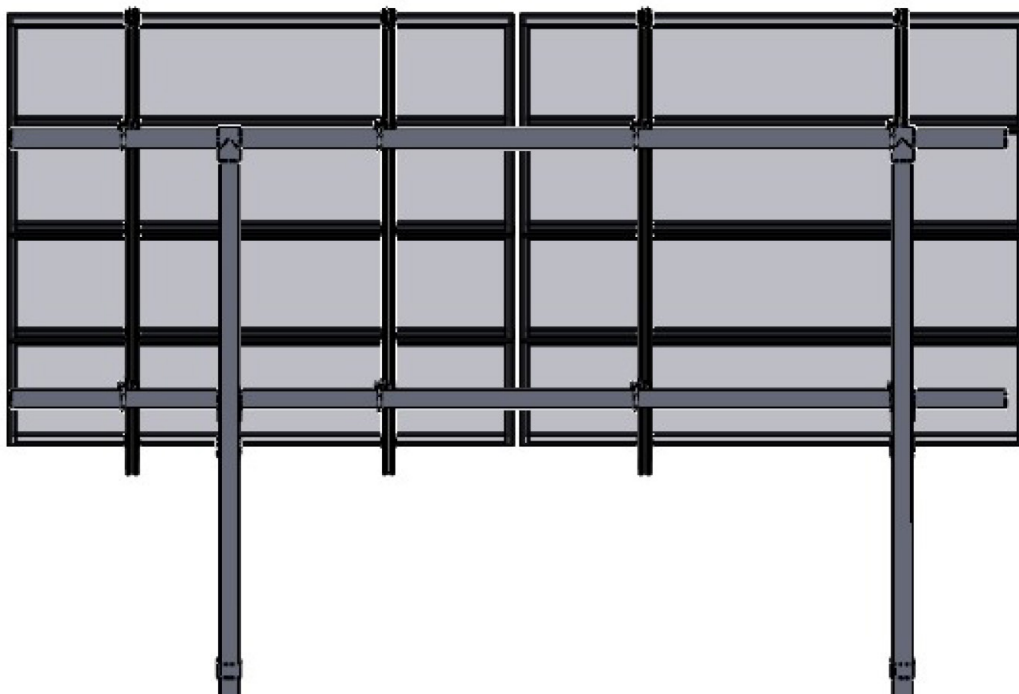

Back View

**Certified Module List for UL61730 Listing Program**

Manufacturer	Model
Aleo	P18/P19/S18/S19/S59/S79.
AU Optronics	PM Series
Astronergy	modules with 30, 35, 40, and 45 mm frames aaSMbbyC/zz-xxx Where "aa" can be CH or A; "bb" can be 60, 66, or 72; "yy" can be blank, 10 or 12; "C" can M, P, M(BL), M-HC, M(BL)-HC, P-HC, M(DG), or M(DGT); and "zz" can be blank, HV, F-B, or F-BH
Auxin	Modules with 35 mm frames AXN10YxxxZ where "y" can be M or B; "z" can be B, W or C modules with 40 mm frames AXN6y6zAxxx Where "y" can be M or P; "z" can be 08, 09, 10, 11, or 12; and "A" can be F or T
Axitec	Modules with 35 and 40 mm frames AC-xxxY/aaZZb Where "Y" can be M, P or MH; "aa" can be blank, 125- or 156-; "ZZ" can be 54, 60, 72, 120, or 144; "b" can be S
Boviet	Boviet modules with 35 and 40mm frames - BVMZZaaYY-xxxBcc Where "ZZ" can be 66 or 76; "aa" can be 9, 10 or 12; "YY" is M or P; and "B" can be blank, L or S; and "cc" can be blank, H, H-BF, H-BF-DG, H-HC, H-HC-BF, H-HC-BF-DG, HC-BF or HC-BF-DG]
BYD	BYD modules with 35 mm frames BYDxxxAY-ZZ Where "A" can be M6, P6, MH or PH; "Y" can be C or K; and "ZZ" can be 30 or 36
Canadian Solar	Canadian Solar modules with 30, 32, 35, and 40 mm frames - CSbY-xxxZ Where "b" can be 1, 3, 6, 6.2 or 7; "Y" can be H, K, L, N, P, R, U, V, W, X, Y, -48TM, or -54TM; and "Z" can be H, M, P, MS, PX, M-SD, P-AG, P-SD, MB-AG, PB-AG, MS-AG, MS-SD, MS-HL, HP, T, PB-AG, or TB-AG
CentrsoSolar	C and E series.
Certainteed	CertainTeed modules with 35 and 40 frames CTxxxYZZ-AA Where "Y" can be M, P, or HC; "ZZ" can be 00,01, 10, or 11; and "AA" can be 01, 02, 03, or 04
CSUN	Csun modules with 35 and 40 mm frames - YYxxx-zzAbb Where "YY" is CSUN or SST; "zz" is blank, 60, or 72; and "A" is blank, P, M or MM; "bb" is blank, BB, 5BB, BW, or ROOF
Dehui	Dehui modules with 30, 35 and 40mm frames - DH-MYYYY-xxx Where "YYY" can be 760, 772, 860, 872; and "Z" can be B, F or W
Eco Solargy	ORION 1000 ECOXXH156P-60, APOLLO 1000 ECOXXT156M-60, and APOLLO 1000 ECOXXA156M-60.
ET Solar	30, 35, 40, and 50 mm frames ET-Y6ZZxxxAA Where "Y" can be P, L, or M; "ZZ" can be 60, 72 or 72BH; and "AA" can be GL, WB, WW, BB, WBG, WWG, WBAC, WBCO, WWCO, WWBCO or BBAC
GCL	40mm frame: GCL-P6/72, 35mm frame: GCL-P6/72, GCL-P6/72H, GCL-M6/72, GCL-M6/72H, 35mm frame (Black frame): GCL-P6/60, GCL-M6/60
GigaWatt Solar:	Gigawatt modules with 40 mm frames - GWxxxYY Where "YY" can be either PB or MB
Hansol	Hansol modules with 35 and 40 frames HSxxxYY-zz Where "YY" can be PB, PD, PE, TB, TD, UB, UD, or UE; and "zz" can be AH2, AN1, AN3, AN4, HH2, HV1, or JH2]
Heliene	Heliene modules with 35 or 40 mm frames - YYZxxxA Where "YY" can be 36, 60, 72, 96, 108, 120, 132, 144 or 156; "ZZ" can be HC, M, P, or MBLK, M10-SL, M10-SL-BLK, M10 Bifacial or M10 SL-Bifacial; and "A" can be blank, HomePV, Bifacial, M10 NTYP SL, or M10 NTYP SL Bifacial
Hounen	Hounen modules with 30 and 35 mm frames HNMY-AAA-xxxM, Where "Y" can be 6, 7 or 8; "AAA" can be 72, NH120, NH144, NHDB144, NHLDD144, SH108, SH144, SHDB108, SHDB120, SHDB132, SHDB144, SHDB156, SHLDD120, SHLDD144, SPDB108, SPDB120, SPDB144, SPDB132, SPDB156, TP120, TPLDD120 or UHLDD144; and "M" can be M or N
HT Solar	HT60-156(M) (NDV) (-F), HT 72-156(M/P)
Hyundai	Hyundai modules with 30, 32, 33, 35 and 40 mm frames HiY-SxxxZZ Where "Y" can be A, D, N or S; "S" can be M, S or T; and "ZZ" can be GI, HG, HI, KI, MI, MF, MG, NF(BK), NJ, OJ, PI, RI, RG, RG(BF), RG(BK), SG, TI, TG, YH(BK), XG(BK), LE-FB(ZB),
ITEK	40 and 50 mm frames IT-xxx-YY Where "YY" can be blank, HE, or SE, or SE72
JA Solar	JA Solar modules with 30, 35 and 40 mm frames JAyzz-bbww-xxx/aa Where "yy" can be M, P, M6 or P6; "zz" can be blank, (K), (L), (R), (V), (BK), (FA), (TG), (FA)(R), (L)(BK), (L) (TG), (R)(BK), (R)(TG), (V)(BK), (BK)(TG), or (L)(BK)(TG); "bb" can be 48, 54, 60, 66, or 72; "ww" can be D09, D40, D41, D45, S01, S02, S03, S06, S09, S10, S12; and "aa" can be BP, LB, MB, MR, SI, SC, PR, 3BB, 4BB, 4BB/RE, 5BB
Japan Solar	JPS-xxxP-60 (35mm), JPS-xxxM-60 (35mm), JPS-xxxP-72 (40mm), JPS-xxxM-60-BB (35mm), JPS-xxxP-72-BB (40mm)
Jinko	35 and 40 mm frames JKMYxxxZZ-aa Where "Y" can either be blank or S; "ZZ" can be M, P, or PP; and "aa" can be blank, 60, 60B, 60H, 60L, 60BL, 60HL, 60HB, 60HBL, 6HBL-EP, 60-J4, 60B-J4, 60B-EP, 60(Plus), 60-V, 60-MX, 7RL3-V, 7RL3-TV, 72, 72B, 72-J4, 72B-J4, 72(Plus), 72-V, 72H-V, 72L-V, 72HL-V, 72-MX, 72H-BDVP, 72HL-TV, or 72HL-V-MX3
Kyocera	KU26x-6MCA where x is 0 or 5.
LG	[LG modules with 35, 40, and 46 mm frames - LGxxxYaZ-bb Where "Y" can be A, E, M, N, Q, S; "a" can be A, 1, 2 or 3 "Z" can be C, K, T, or W; and "bb" can be A3, A5, A6, B3, B6, E6, G3, G4, J5, K4, L5, N5, V5 or V6]
LONGi	[Longi modules with 30, 35 and 40 mm frames - LRa-YYZZ-xxxM Where "a" can be 4, 5 or 6; "YY" can be blank, 60 or 72; and "ZZ" can be blank, BK, BP, HV, PB, PE, PH, HBD, HIB, HIH, HPB, HPH, or HIBD]
Maxeon	Maxeon (G3 or G4) or InvisiMount (G5) 40 and 46 mm frames - SPR-Zb-xxx-YY Where "Z" is either A, E, P, MAX, or X; "b" can be blank, 17, 18, 19, 20, 21, or 22; and "YY" can be blank, BLK, COM, C-AC, D-AC, E-AC, BLK-E-AC, G-AC, BLK-C-AC, or BLK-D-AC
Mission Solar (mSolar)	33 and 40 mm frames YYYbxxxZZaa - Where "YYY" can be MSE, MSI, MST, TXI or TXS; "bb" can be blank, 6, 10 or 60A; "ZZ" can be blank, HN, HT, MM, SE, SO, SQ, SR, SX, TS, 108, 120 or 144; and "aa" can be blank, 0B, 1J, 2B, BB, BW, 4G, 4J, 4S, 4T, 5R, 5T, 6O, gJ, 6S, gW, 6Z, 8K, 8T, 9R, 9S or 9Z
Mitsubishi	Mitsubishi modules with 46 mm frames - PV-MYYxxxZZ Where "YY" can be LE or JE; and "ZZ" can be either HD, HD2, or FB
NSP	D6M and D6P
Optivolt	OPT10MxxxW where W is a variable that can be B or W for black or white backsheet
Panasonic	30 mm frames EVPVxxxA, Where "A" can be blank or H, K, HK or PK or Panasonic modules with 35 and 40 mm frames VBHNxxxYYZZA Where "YY" can be either KA, RA, SA or ZA; "zz" can be either 01, 02, 03, 04, 06, 06B, 11, 11B, 15, 15B, 16, 16B, 17, or 18; and "A" can be blank, E, G, or N
Peimar	40 mm frames SbxxxYzz Where "b" can be G, M or P; "Y" can be M or P; and "zz" can be blank, (BF) or (FB)

**Certified Module List for UL61730 Listing Program**

Manufacturer	Model
Phono Solar	Phono Solar modules with 35, 40, and 45 mm frames - PSxxxY-ZZ/A Where "Y" can be M, M1, MH, M1H, M4, M4H or P; "ZZ" can be 20 or 24; and "A" can be F, T, U, UH, or TH]
Q CELLS	Q CELLS Modules with 30, 32, 35, 40 mm frames aaYY-ZZ-xxx where "aa" can be Q or B; "YY" can be PLUS, PRO, PEAK, LINE PRO, LINE PLUS, PLUS DUO or PEAK DUO; TRON "ZZ" can be G3, G3.1, G4, G4.1, L-G2, L-G2.3, L-G3, L-G3.1, L-G3y, L-G4, L-G4.2, L-G4y, LG4.2/TAA, BFR-G3, BLK-G3, BFR-G3.1, BLK-G3.1, BFR-G4, BFR-G4.1, BFR G4.3, BLK-G4.1, G4/SC, G4.1/SC, G4.1/TAA, G4.1/MAX, BFR G4.1/TAA, BFR G4.1/MAX, BLK G4.1/TAA, BLK G4.1/SC, EC-G4.4, G5, G5/SC, G5/TS, BLK-G5, BLK-G5/SC, BLK-G5/TS, L-G5, L-G5.1, L-G5.2, L-G5.2/H, L-G5.3, G6, G6/SC, G6/TS, G6+/TS, G6+, BLK-G6, L-G6, L-G6.1, L-G6.2, L-G6.3, G7, BLK-G6+, BLK-G6+/AC, BLK-G6+/HL, BLK-G6+/SC, BLK-G6/TS, BLK-G6+/TS, BLK-G7, G7.2, G8, BLK-G8, G8+, BLK-G8+ L-G7, L-G7.1, L-G7.2, L-G7.3, L-G8, L-G8.1, L-G8.2, L-G8.3, L-G8.3/BFF, L-G8.3/BFG, L-G8.3/BGT, ML-G9, BLK ML-G9, ML-G9+, BLK ML-G9+, ML-G10, BLK ML-G10, ML-G10+, BLK ML-G10+, ML-G10.a, BLK ML-G10.a, ML-G10.a+, BLK ML-G10.a+, XL-G9, XL-G9.2, XL-G9.3, XL-G9.3/BFG, BLK G10+/AC, BLK-G10+/HL, ML-G10, BLK ML-G10, ML-G10+, BLK ML-G10+, ML-G10.a, BLK ML-G10.a, ML-G10.a+, BLK ML-G10.a+, BLK ML-G10.C+, BLK ML-G10.C1+/AC, BLK ML-G10+/t, XL-G2.3/BFG, XL-G9, XL-G9.2, XL-G9.3, XL-G9.3/BFG, XL-G10.d/BFG, XL-G10.d/BGT, XL-G10.3/BFG, XL-G10.3/BGT, XL-G11.3/BFG or XL-G11S.3/BFG, BLK M-G2.F1+/AC, BLK M-G2.H1+/AC, BLK M-G2+/AC, BLK M-G2.F+, BLK M-G2.H+, ML-G12S.3/BFG, ML-G12S.7/BFG
Risen	RSM72-6 (MDG) (M), RSM60-6
REC Solar	REC modules with 30, 38 and 45 mm frames - RECxxxYYZZ Where "YY" can be AA, M, NP, NP2, NP3, PE, PE72, TP, TP2, TP2M, TP2SM, TP2S, TP3M or TP4; and "ZZ" can be blank, Black, BLK, BLK2, SLV, 72, Pure, or Pure-R, Pure-RX or Pure 2
Renesola	Virtus II with module ratings of 250-260 in increments of 5. 156 series with module ratings of 270-275.
S-Energy	S-Energy modules with 35 and 40mm frames - SABB-CCYYY-xxxZ Where "A" can be C, D, L or N; "BB" can be blank, 20, 25, 40 or 45; "CC" can be blank, 60 or 72; "YYY" can be blank, BDE, MAE, MAI, MBE, MBI, MCE or MCI; and "Z" can be V, M-10, P-10 or P-15
Seraphim Energy Group	Seraphim modules with 30, 35, and 40 mm frames - SEG-aYY-xxxZZ Where "a" can be blank, 6 or B; "YY" can be blank, MA, MB, PA, or PB; and "ZZ" can be blank, BB, BG, BW, HV, WB, WW, BMB, BMA-HV, BMA-BG, BMB-HV
Seraphim USA	Seraphim modules with 30, 35, 40 and 50 mm frames - SRP-xxx-YYY-ZZ Where "xxx" is the module power rating; and "YYY" can be BMA, BMD, 6MA, 6MB, 6PA, 6PB, 6QA-XX-XX, and 6QB-XX-XX; ZZ is blank, BB, BG or HV
Sharp	60 and 72 NUSA-xxx/NUSC-xxx
Silfab	Silfab Modules with 35 and 38 mm frames - SYY-Z-xxxAb Where "YY" can be IL, SA, LA, SG or LG; "Z" can be blank, M, P, or X; "A" can be blank, B, H, M, N, Q, or X; and "b" can be A, C, C+, D, G, K, L, M, M+, N, T, U, X, HC+, HM, and HN
SolarWorld	Sunmodule Plus, Protect, Bisun, XL, Bisun XL, may be followed by mono, poly, duo, black, bk, or clear; modules with 31, 33 or 46 mm frames SW-xxx, SolarWorld Sunmodule Plus, Protect, Bisun, XL, Bisun XL, may be followed by mono, poly, duo, black, bk, or clear; modules with 33 mm frames SWA-xxx
Solar4America	S4A550-144MH10STT
Solaria	40 mm frames PowerXT xxxY-ZZ Where "Y" can be R or C; and "ZZ" can be AC, BD, BX, BY, PD, PM, PM-AC, PX, PZ, WX or WZ
Sonali	SS 230 - 265
SunEdison	SunEdison Modules with 35, 40 & 50 mm frames - SE-YxxxZABCDE Where "Y" can be B, F, H, P, R, or Z; "Z" can be 0 or 4; "A" can be B,C,D,E,H,I,J,K,L,M, or N ; "B" can be B or W; "C" can be A or C; "D" can be 3, 7, 8, or 9; and "E" can be 0, 1 or 2
Suniva	Suniva modules with 35, 38, 40, 46, and 50 mm frames - OPTxxx-AA-B-YYY-Z and MVxxx-AA-B-YYY-Z Where "AA" is either 60 or 72; "B" is either 4 or 5; "YYY" is either 100,101,700,1B0, or 1B1; and "Z" is blank or B
SunSpark	40 mm frames SYY-xxxZ-A Where "YY" can be MX or ST; and "Z" can be M, MB, M3, M3B, P or W; and "A" can be 60 or 72
Suntech	35, 40 and 50mm frames STPxxxz-aa Where "y" is blank or S; and "zz" can be 20, 24, A60 or A72U; and "aa" can be Vd, Vem, Vfw, Vfth, Wdb, Wde, Wd, or Wfthb
Talesun	Talesun modules with 30, 35 and 40mm frames - TA6yZZaaxxx-b Where "A" can be D or P, "y" can be blank, F, G, H, I, or L; "ZZ" can be 60 or 72; "aa" can be M, M(H), or P; and "b" can be blank, B, T, or (H)
Tesla	Tesla modules with 40 mm frames - TxxxY Where "Y" can be H or S
Trina Solar	Trina Modules with 30, 35, 40 and 46mm frames - TSM-xxxYYZZ Where "YY" can be DD05, DD06, DD14, DE14, DE15, DE15V, DEG15, DEG15VC, DE19, DEG19C.20, DE06X, PA05, PC05, PD05, PD06, PA14, PC14, PD14, PE14, PE15, NE19RC, NE09RH.05, NED19RC.20, NEG21C.20, NE19RC, NEG19RC.20 ; and "ZZ" can be blank, .05, .05(II), .08, .10, .18, .08D, .18D, 0.82, .002, .00S, 05S, 08S, .20(II), A, A.05, A.08, A.10, A.18, (II), A(II), A.05(II), A.08(II), A.082(II), A.10(II), A.18(II), H, H(II), H.05(II), H.08(II), HC.20(II), HC.20(II), M, M(II), M.05(II), MC.20(II)
Upsolar	UP-MxxxP, UP-MxxxP-B, UP-MxxxM, UP-MxxxM-B
URECO	FBM_M7G-BB and FBM_MFG-BB
Vikram	40 mm frames VSyy.ZZ.AAA.bb Where "yy" can be M, P, MBB, MH, MS, MHBB, or PBB; "ZZ" can be 60 or 72; "AAA" is the module power rating; and "bb" can be 03.04 or 05
VSUN	108 BMH, 108 BMH-DG, 132 BMH, 144BMH-DG
Yingli	YL xxx P-29b, YLM 60, YLM 72, YGE, YGE-VG, YLM, YL xxx P-35b, YL xxx D-30b, YL xxx D-36b
Waaree	AC, Adiya 60/72 Mono/Poly Black, Adiya 60/72 Multi
Winaico	35 and 40 mm frames Wsy-xxxZa Where "y" can be either P or T; "Z" can be either M, P, or MX; and "a" can be blank or 6
ZNShine	ZN Shine modules with 30 and 35 mm frames ZXMY-AAA-xxx/M, Where "Y" can be 6, 7 or 8; "AAA" can be 72, NH120, NH144, NHDB144, NHLDD144, SH108, SH144, SHDB120, SHDB144, SHLDD120, SHLDD144, TP120, TPLDD120 or UHLDD144; and "M" can be M or N
<b>Certified Power Optimizer List for UL2703 Listing Program</b>	
Manufacturer	Model
Enphase	M250-72, 250-60, M215-60, C250-72, S230, S280, IQ 6, IQ 6+, IQ 7, IQ 7+, IQ 7X, Q Aggregator
Solar Edge	P300, P320, P340, P370, P400, P405, P505, P600, P700, P730, P800p, P800s, P850, P860