

Conext™ SW Inverter Charger

Conext SW 2524 120/240 (865-2524)

Conext SW 4024 120/240 (865-4024)

Installation Guide

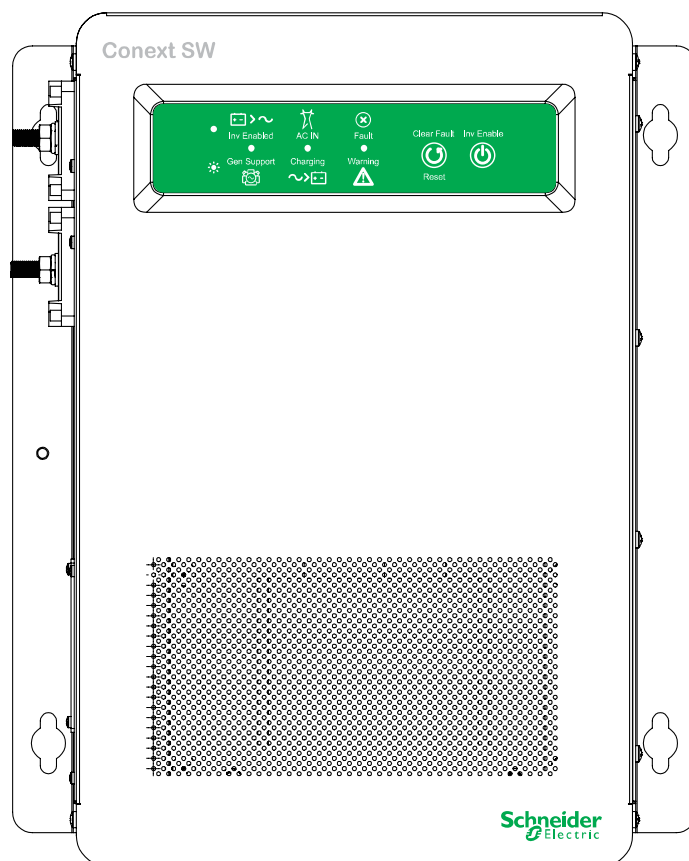

xanbus™
E N A B L E D

Conext SW Inverter Charger

Conext SW 2524 120/240 (865-2524)

Conext SW 4024 120/240 (865-4024)

Installation Guide

Copyright © 2012 Schneider Electric. All Rights Reserved. All trademarks are owned by Schneider Electric Industries SAS or its affiliated companies.

Exclusion for Documentation

UNLESS SPECIFICALLY AGREED TO IN WRITING, SELLER

(A) MAKES NO WARRANTY AS TO THE ACCURACY, SUFFICIENCY OR SUITABILITY OF ANY TECHNICAL OR OTHER INFORMATION PROVIDED IN ITS MANUALS OR OTHER DOCUMENTATION;

(B) ASSUMES NO RESPONSIBILITY OR LIABILITY FOR LOSSES, DAMAGES, COSTS OR EXPENSES, WHETHER SPECIAL, DIRECT, INDIRECT, CONSEQUENTIAL OR INCIDENTAL, WHICH MIGHT ARISE OUT OF THE USE OF SUCH INFORMATION. THE USE OF ANY SUCH INFORMATION WILL BE ENTIRELY AT THE USER'S RISK; AND

(C) REMINDS YOU THAT IF THIS MANUAL IS IN ANY LANGUAGE OTHER THAN ENGLISH, ALTHOUGH STEPS HAVE BEEN TAKEN TO MAINTAIN THE ACCURACY OF THE TRANSLATION, THE ACCURACY CANNOT BE GUARANTEED. APPROVED CONTENT IS CONTAINED WITH THE ENGLISH LANGUAGE VERSION WHICH IS POSTED AT WWW.SCHNEIDER-ELECTRIC.COM.

Document Number: 975-0639-01-01 **Revision:** Rev A **Date:** 12-2012

Product Part Numbers: 865-2524, 865-4024

Contact Information www.schneider-electric.com

For other country details please contact your local Schneider Electric Sales Representative or visit the Schneider Electric website at:

<http://www.schneider-electric.com/sites/corporate/en/support/operations/local-operations/local-operations.page>

Information About Your System

As soon as you open your product, record the following information and be sure to keep your proof of purchase.

Serial Number _____

Product Number _____

Purchased From _____

Purchase Date _____

About This Guide

Purpose

The purpose of this Installation Guide is to provide explanations and procedures for installing the Conext SW Inverter/Charger to a main AC power source such as an AC generator for off-grid application or AC mains (main power grid) for power backup application.

Scope

The Guide provides safety and installation guidelines as well as information on tools and wiring. Complete balance of system installation is not covered. For a complete balance of system installation using the Conext SW AC Switchgear, DC Switchgear, and solar charge controllers, consult the Conext SW System Guide.

It does not provide details about particular brands of batteries. You need to consult individual battery manufacturers for this information.

Audience

The Guide is intended for use by anyone who plans to install an off-grid/backup system involving the Conext SW Inverter/Charger. The information in this manual is intended for qualified personnel. Qualified personnel have training, knowledge, and experience in:

- Installing electrical equipment and PV power systems (up to 1000 volts).
- Applying all applicable installation codes.
- Analyzing and reducing the hazards involved in performing electrical work.
- Selecting and using Personal Protective Equipment (PPE).

Organization

This Guide is organized into:

Chapter 1, "Installation" covers installation instructions.

Chapter 2, "Specifications" covers product specifications.

Chapter 3, "Wiring Diagrams" covers overviews of Conext SW BOS installations and wiring diagrams.

Conventions Used

The following conventions are used in this guide.

⚠ DANGER

DANGER indicates an imminently hazardous situation, which, if not avoided, will result in death or serious injury.

⚠ WARNING

WARNING indicates a potentially hazardous situation, which, if not avoided, can result in death or serious injury.

⚠ CAUTION

CAUTION indicates a potentially hazardous situation, which, if not avoided, can result in moderate or minor injury.

NOTICE

NOTICE indicates a potentially hazardous situation, which, if not avoided, can result in equipment damage.

Abbreviations, Acronyms, and Symbols

AC	Alternating Current	LED	Light Emitting Diode
AGS	Automatic Generator Start	SCP	System Control Panel
BOS	Balance of System	SW	Sine Wave
DC	Direct Current	VAC	Volts, Alternating Current
PPE	Personal Protective Equipment	VDC	Volts, Direct Current
PV	Photovoltaic	⊕	Ground

Related Information

You can find more information about Schneider Electric as well as its products and services at www.schneider-electric.com.

Important Safety Instructions

READ AND SAVE THESE INSTRUCTIONS - DO NOT DISCARD

DANGER

ELECTRICAL SHOCK AND FIRE HAZARD

Installation must be done by qualified personnel to ensure compliance with all applicable installation and electrical codes and regulations. Instructions for installing the Conext SW are provided here for use by qualified installers only.

Failure to follow these instructions will result in death or serious injury.

DANGER

ELECTRICAL SHOCK AND FIRE HAZARD

- Read all instructions, cautionary markings, and all other appropriate sections of this guide before installing the Conext SW.
- Exercise extreme caution at all times to prevent accidents.
- Do not cover or obstruct ventilation openings.
- Do not mount in a zero-clearance compartment. Overheating may result.
- Charge only lead-acid batteries.
- Do not open nor disassemble the inverter/charger. There are no user-serviceable parts inside.
- Do not expose to rain or spray.
- Disconnect and lockout all AC and DC sources before servicing. Servicing includes maintenance or cleaning or working on any circuits connected to the inverter/charger. See following note.

Failure to follow these instructions will result in death or serious injury.

NOTE: Turning off inverter mode using the Inv Enable switch on the front panel, disabling the inverter and charger functions using the SCP, and putting the unit in Standby mode will not reduce an electrical shock hazard.

⚠ DANGER

ELECTRIC SHOCK HAZARD

- **For indoor use only.** This inverter/charger is designed for off-grid, solar, backup, and hybrid applications.
- Do not operate the inverter/charger if it has been damaged in any way.
- Do not operate the inverter/charger with damaged or substandard wiring. Wiring must be done by qualified personnel to ensure compliance with all applicable installation codes and regulations.

Failure to follow these instructions will result in death or serious injury.

⚠ WARNING

EXPLOSION AND FIRE HAZARD

- Charge only properly rated (such as 24 V) lead-acid (GEL, AGM, Flooded, or lead-calcium) rechargeable batteries because other battery types may explode.
- Do not work in the vicinity of lead-acid batteries. Batteries generate explosive gases during normal operation. See note #1.
- Do not install and/or operate in compartments containing flammable materials or in locations that require ignition-protected equipment. See notes #2 and #3.

Failure to follow these instructions can result in death or serious injury.

NOTES:

1. Follow these instructions and those published by the battery manufacturer and the manufacturer of any equipment you intend to use in the vicinity of the battery. Review cautionary markings on these products.
2. This inverter/charger contains components which tend to produce arcs or sparks.
3. Locations include any space containing gasoline-powered machinery like a generator, fuel tanks, as well as joints, fittings, or other connections between components of the fuel system.

⚠ CAUTION

FIRE AND BURN HAZARD

Do not cover or obstruct the air intake vent openings and/or install in a zero-clearance compartment.

Failure to follow these instructions can result in moderate or minor injury.

Precautions When Working With Batteries

Important: Battery work and maintenance must be done or supervised by qualified personnel knowledgeable about batteries to ensure compliance with battery handling and maintenance safety precautions.

WARNING

ENERGY AND FIRE HAZARD

- Always wear proper, non-absorbent gloves, complete eye protection, and clothing protection.
- Remove all personal metal items, like rings, bracelets, and watches when working with batteries. See CAUTION below.
- Never smoke or allow a spark or flame near batteries.

Failure to follow these instructions can result in death or serious injury.

CAUTION

BURN HAZARD

Batteries can produce a short circuit current high enough to weld a ring or metal bracelet or the like to the battery terminal, causing a severe burn.

Failure to follow these instructions can result in moderate or minor injury.

CAUTION

ELECTRIC SHOCK HAZARD

- Determine if the battery is inadvertently grounded. If inadvertently grounded, remove the source from ground.
- Avoid contact with any part of a grounded battery.
- Remove ground during installation and maintenance.

Failure to follow these instructions can result in moderate or minor injury.

⚠ CAUTION

CHEMICAL HAZARD

- Never allow battery acid to drip when reading specific gravity or filling battery.
- Make sure the area around the battery is well ventilated.
- Make sure the voltage of the batteries matches the rated nominal output DC voltage of the inverter/charger.
- Study and follow all of the battery manufacturer's specific precautions, such as removing or not removing cell caps while charging, whether equalization is acceptable for your battery, and recommended rates of charge.

Failure to follow these instructions can result in moderate or minor injury.

NOTICE

RISK OF INVERTER/CHARGER DAMAGE

Never place the Conext SW Inverter/Charger unit directly above batteries; gases from a battery will corrode and damage the inverter/charger.

Failure to follow these instructions can result in damage to equipment.

Regulatory

The Conext SW Inverter/Charger is certified to appropriate North American standards. For more information see "Regulatory Approvals" under Specifications.

The Conext SW Inverter/Charger is intended to be used for off-grid, backup, solar, and hybrid applications.

It is not intended for other applications as it may not comply with the additional safety code requirements needed for those other applications. See "Limitations On Use" below.

⚠ WARNING

LIMITATIONS ON USE

Do not use in connection with life support systems or other medical equipment.

Failure to follow these instructions can result in death or serious injury.

FCC Information to the User

This equipment has been tested and found to comply with the limits for a Class B digital device, pursuant to part 15 of the FCC Rules. These limits are designed to provide reasonable protection against harmful interference in a residential installation. This equipment generates, uses, and can radiate radio frequency energy and, if not installed and used in accordance with the instructions, may cause harmful interference to radio communications.

However, there is no guarantee that interference will not occur in a particular installation. If this equipment does cause harmful interference to radio or television reception, which can be determined by turning the equipment off and on, the user is encouraged to try to correct the interference by one or more of the following measures:

- Reorient or relocate the receiving antenna.
- Increase the separation between the equipment and receiver.
- Connect the equipment into an outlet on a circuit different from that to which the receiver is connected.
- Consult the dealer or an experienced radio/TV technician for help.

Contents

Important Safety Instructions

Precautions When Working With Batteries	vii
Regulatory	viii
FCC Information to the User	ix

1 Installation

Materials List	1-2
Conext SW Front and Side Panels	1-3
Conext SW AC/DC/Ports Side Panel	1-5
Conext SW Supplied Accessories	1-6
Conext SW Required Accessory	1-7
Installation Information	1-8
Before You Begin the Installation	1-8
Installation Codes	1-8
Xanbus Network System	1-9
Xanbus System	1-9
Xanbus-enabled Products and Other Accessories	1-10
Installation Planning	1-11
Planning Preparations	1-11
Components of the Inverter Power System	1-11
AC, DC, and Network Components	1-12
Unpacking and Inspecting the Conext SW Inverter/Charger	1-16
Installation Tools and Materials	1-17
Tools	1-17
Materials	1-17
Inverter/Charger Installation-	1-18
Overview	1-18
Step 1: Choosing a Location for the Inverter/Charger	1-19
Step 2: Mounting the Inverter/Charger	1-19
Step 3: Connecting the AC Input and AC Output Wires	1-21
General AC Wiring Considerations	1-21
Step 4: Installing the DC Switchgear and Connecting the DC Cables	1-23
DC Connection Precautions	1-23
Installing the DC Switchgear next to Conext SW Inverter/Charger	1-24
Connecting the DC Cables to the DC Switchgear	1-26
Step 5: Connecting the BTS and Xanbus-enabled Components	1-28
Step 6: Performing Checks Prior to Initial Start-Up	1-30
Step 7: Testing Your Installation	1-30
Testing in Invert Mode	1-31
Testing in Charge Mode and AC Bypass Mode	1-31
Installation Complete	1-31

Multiple Unit Configuration - - - - -	1-32
DC Connections for Multiple Unit Configuration - - - - -	1-33
Neutral Wiring for Inverters in Multiple Unit Configuration - - - - -	1-34
Configuring the System for Multiple Unit Operation - - - - -	1-35
Search Mode Operation in Multiple Unit Configuration - - - - -	1-36
Disabling Search Mode on the Master Unit - - - - -	1-36
Setting Search Mode on the Slave Unit - - - - -	1-36
Wiring Schematic - - - - -	1-36
Battery Information - - - - -	1-37
Battery Bank Sizing - - - - -	1-37
Estimating Battery Requirements - - - - -	1-38
Calculating Battery Size - - - - -	1-38
Battery Banks - - - - -	1-39
Battery Bank Sizing Worksheet - - - - -	1-39
Restrictions on Motor Size - - - - -	1-40
Battery Cabling and Hook-up Configurations - - - - -	1-41
Battery Parallel Connection - - - - -	1-41
Battery Series Connection - - - - -	1-42
Battery Series-Parallel Connections - - - - -	1-42

2 Specifications

Inverter Specifications - - - - -	2-2
Charger Specifications - - - - -	2-3
AC Transfer Specifications - - - - -	2-4
Physical Specifications - - - - -	2-4
Environmental Specifications - - - - -	2-5
Regulatory - - - - -	2-5

3 Wiring Diagrams

Figures

Figure 1-1	Materials List- - - - -	1-2
Figure 1-2	Conext SW Front and Side Panels- - - - -	1-3
Figure 1-3	Front Panel Buttons and Status LEDs - - - - -	1-4
Figure 1-4	AC and DC Terminals, Network and Communication Ports Panel- - - - -	1-5
Figure 1-5	Supplied Accessories - - - - -	1-6
Figure 1-6	DC Switchgear - - - - -	1-7
Figure 1-7	Xanbus System Diagram Example - - - - -	1-9
Figure 1-8	AC, DC, and Network Components- - - - -	1-12
Figure 1-9	AC, DC, and Network Components- - - - -	1-13
Figure 1-10	Conext SW Mounting Instructions - - - - -	1-20
Figure 1-11	Conext SW AC INPUT and OUTPUT Connections - - - - -	1-22
Figure 1-12	Installing the DC Switchgear- - - - -	1-25
Figure 1-13	Conext SW DC Connections - - - - -	1-27
Figure 1-14	Conext SW BTS and Xanbus Connections - - - - -	1-29
Figure 1-15	Conext SW Front Panel- - - - -	1-30
Figure 1-16	Multiple Unit Configuration Using Two Conext SW Units - - - - -	1-32
Figure 1-17	Connecting Battery Cables- - - - -	1-33
Figure 1-18	Neutral Wiring for Multiple Unit Configuration - - - - -	1-34
Figure 1-19	Multi Menu Screen- - - - -	1-35
Figure 1-20	Batteries Connected in Parallel - - - - -	1-41
Figure 1-21	Batteries Connected in Series- - - - -	1-42
Figure 1-22	Batteries in Series-Parallel Connections- - - - -	1-42
Figure 2-1	Output Power versus Temperature Derating Graph - - - - -	2-5

Tables

Table 1-1	AC Wire Size In and Out of the Inverter/Charger-----	1-14
Table 1-2	Recommended Battery Cable Sizes -----	1-15
Table 1-3	Recommended Fuse and Breaker Sizes -----	1-15
Table 1-4	Battery Sizing Example -----	1-39
Table 1-5	Battery Sizing Worksheet -----	1-40

1

Installation

The following topics will be covered in this chapter.

- Materials List
- Installation Information
- Xanbus Network System
- Installation Planning
- Inverter/Charger Installation
- Multiple Unit Configuration
- Battery Information
- Wiring Diagrams

Materials List

The Conext SW ships with the following items:

- One Conext SW unit
- One set of owner's and installation guides
- One Battery Temperature Sensor (BTS)
- Two Xanbus network terminators
- Two sets of 5/16"-8 nuts and washers for the DC terminals,
- Two DC terminal covers (red and black) with two sets of #6-32 screws
- One Installation bracket with one set of M6 nuts for mounting (not shown)

NOTE: If any of the items are missing, contact your dealer and/or sales representative. For code-compliant installations in Canada and USA, the DC Switchgear accessory is required. See "Conext SW DC Switchgear*" on page 1-10.

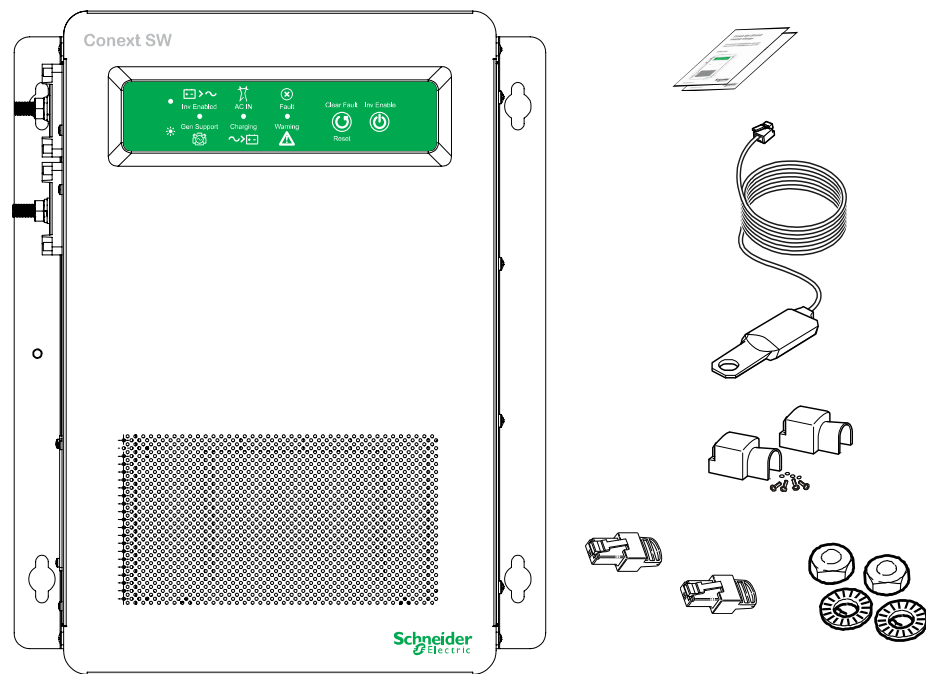

Figure 1-1 Materials List

Conext SW Front and Side Panels

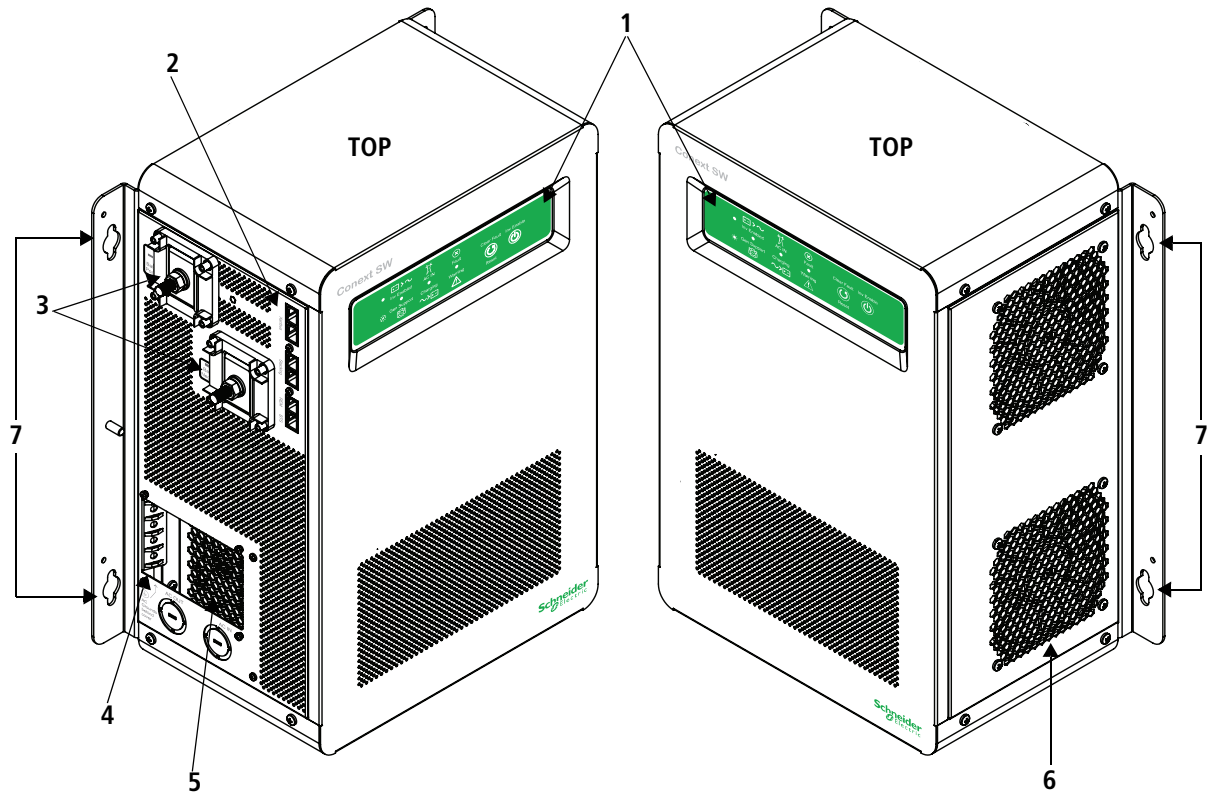

Figure 1-2 Conext SW Front and Side Panels

Before you begin to operate the Conext SW after installation, review the front panel features shown in Figure 1-3 and described in the next table. A detailed view of the lights and buttons on the front panel is also shown.

Item	Description
1	Front Panel contains the Inv Enable and Clear Fault Reset buttons, as well as various LEDs (status indicator lights). See “Front Panel Buttons and Status LEDs” on page 1-4.
2	Network and communications ports. See “AC and DC Terminals, Network and Communication Ports Panel” on page 1-5.
3	DC battery terminals. See “AC and DC Terminals, Network and Communication Ports Panel” on page 1-5.
4	AC Ground terminals. See “AC and DC Terminals, Network and Communication Ports Panel” on page 1-5.

Item	Description
5	AC line terminals. See “AC and DC Terminals, Network and Communication Ports Panel” on page 1–5.
6	Two variable-speed cooling fans maintain a cool internal temperature of critical components. The two fans control airflow through the transformer and power compartments of the unit. Ensure at least 10" (254 mm) of clearance for proper ventilation.
7	Mounting holes for permanent installation. See “Step 2: Mounting the Inverter/Charger” on page 1–19.

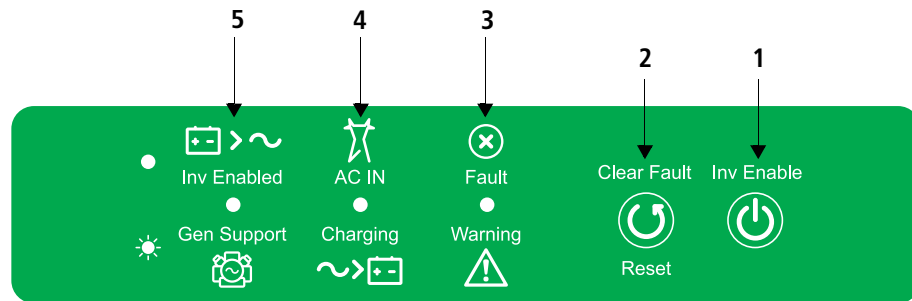

Figure 1-3 Front Panel Buttons and Status LEDs

Item	Description
1	Inv Enable button is used to enable and disable inverter mode. “Enabled” is different from the inverter being “on”. When enabled, the inverter can be on or off. When disabled, the inverter is always off.
2	Clear Fault Reset button is used to clear any detected faults if pressed momentarily. If held down for more than three seconds, the unit will reset (reboot) itself.
3	Fault Warning LED illuminates steadily if a fault is detected (a fault detection condition) and flashes intermittently when a warning condition is active.
4	When AC is present and qualified, the AC IN LED will illuminate steadily indicating also that AC is passing through. Charging LED flashes intermittently when the Conext SW is in charge mode and is producing DC output to charge your batteries.
5	The Inv Enabled LED illuminates steadily when invert mode is enabled. If AC is present and invert mode is enabled, this LED remains illuminated even though AC power is being passed through. Gen Support LED flashes intermittently when the inverter is in generator support mode and is assisting the generator.

Conext SW AC/DC/Ports Side Panel

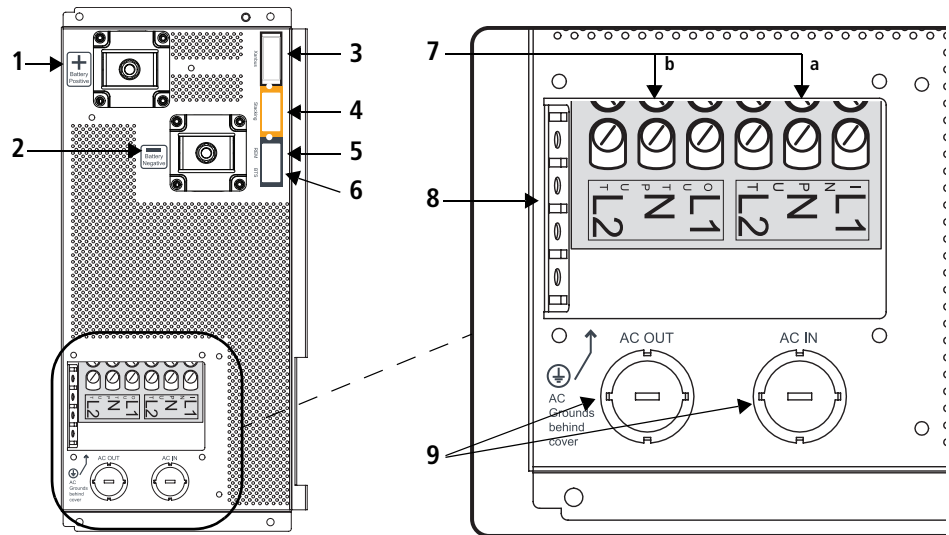

Figure 1-4 AC and DC Terminals, Network and Communication Ports Panel

Item	Description
1	Battery Positive (+) (red) DC terminal connects to the positive bus bar of the DC Switchgear.
2	Battery Negative (-) (black) DC terminal connects to the negative bus bar of the DC Switchgear.
3	XANBUS interface ports are used to connect Xanbus-enabled devices including the optional SCP and AGS.
4	STACKING port. Feature not available in this model.
5	Remote (REM) port provides connection for the on/off remote switch.
6	Battery temperature sensor (BTS) port provides connection for the battery temperature sensor (supplied).
7	AC input/output lines wiring compartment access panel without the compartment cover. (a) AC Input terminal block is a screw-type terminal block for attaching AC input wires. The terminals are labeled INPUT N for Neutral and INPUT L1 and L2 for split-phase lines 1 and 2 respectively. (b) AC Output terminal block is a screw-type terminal block for attaching AC output wires. The terminals are labeled OUTPUT N for Neutral and OUTPUT L1 and L2 for split-phase lines 1 and 2 respectively.
8	All ⊕ Ground terminals are along the tab (as shown) of the AC wiring compartment access panel opening.
9	AC knockouts (3/4" and 1") provide access for AC cables (both input and output wiring). Detach the knockout covers and install strain-relief clamps available in hardware and electrical stores.
Not shown	AC wiring compartment cover that is taken out during wiring and put back in when wiring has been completed.

Conext SW Supplied Accessories

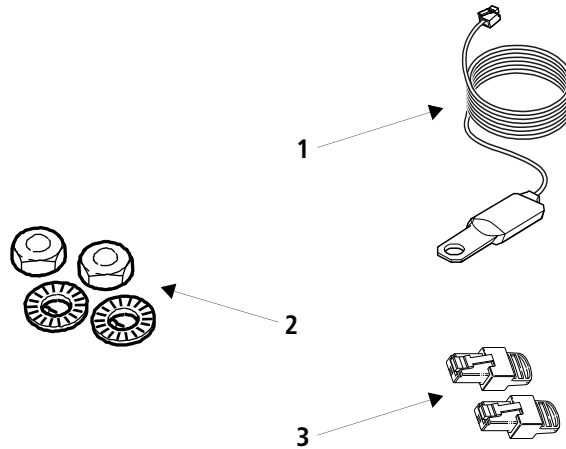

Figure 1-5 Supplied Accessories

NOTE: If any of the supplied accessories are missing, contact customer service for replacement. See “Contact Information www.schneider-electric.com” on page ii.

Item	Description
1	<p>BTS, the Battery Temperature Sensor consists of:</p> <ul style="list-style-type: none"> • Connector that plugs into the BTS port on the Conext SW. • Sensor cable is 25 feet (7.6 meters). • Sensor can be mounted on the side of the battery case or on the negative battery terminal. <p>NOTE: The BTS continuously measures the temperature of the battery and adjusts the charger output for a more accurate, temperature-compensated charge.</p>
2	Two sets of M6 nuts and washers are used to secure the DC Switchgear’s bus bars to the DC battery terminals.
3	<p>Two Xanbus network terminators are used to properly terminate each of the two ends of the daisy-chained Xanbus network. For example, if the SCP is connected to the inverter/charger, one terminator will be plugged to the SCP, one network cable will connect both devices, and one terminator will be plugged to the inverter/charger.</p> <p>IMPORTANT: The SCP may perform erratically if the Xanbus network is not properly terminated.</p>
4	Two DC terminal covers (not shown) - not needed for installation with the DC Switchgear which is required in Canada and the USA.
5	Installation bracket (not shown)

Conext SW Required Accessory

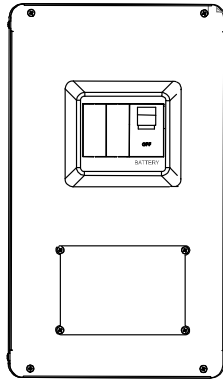

Figure 1-6 DC Switchgear

NOTE: The DC Switchgear is required by electrical code to be installed with the Conext SW inverter/charger in installations within Canada and the USA.

Installation Information

Before You Begin the Installation

Before beginning your installation:

- Read the entire Installation Guide so you can plan the installation from beginning to end.
- Assemble all the tools and materials you require for the installation.
- Review the Important Safety Instructions on page v.
- Be aware of all safety and electrical codes which must be met.

⚠ DANGER

ELECTRICAL SHOCK AND FIRE HAZARD

- All wiring must be done by qualified personnel to ensure compliance with all applicable installation codes and regulations.
- Disconnect and lockout all AC and DC power sources.
- Disable and secure all AC and DC disconnect devices and automatic generator starting devices.

Failure to follow these instructions will result in death or serious injury.

Installation Codes

Applicable installation codes vary depending on the specific location and application of the installation. Some examples are:

Applicable installation codes vary depending on the specific location and application of the installation. Some examples are:

- National Electrical Code (NFPA 70)
- Canadian Electrical Code (CSA C22.1)

Xanbus Network System

Xanbus System

The Xanbus system includes the Conext SW and other Xanbus-enabled devices. The Conext SW is the device in a Xanbus system that typically provides network power—500 mA at 12 VDC. All of the Xanbus-enabled devices, such as the Conext SW, the SCP, and the AGS are able to communicate their settings and activity to each other.

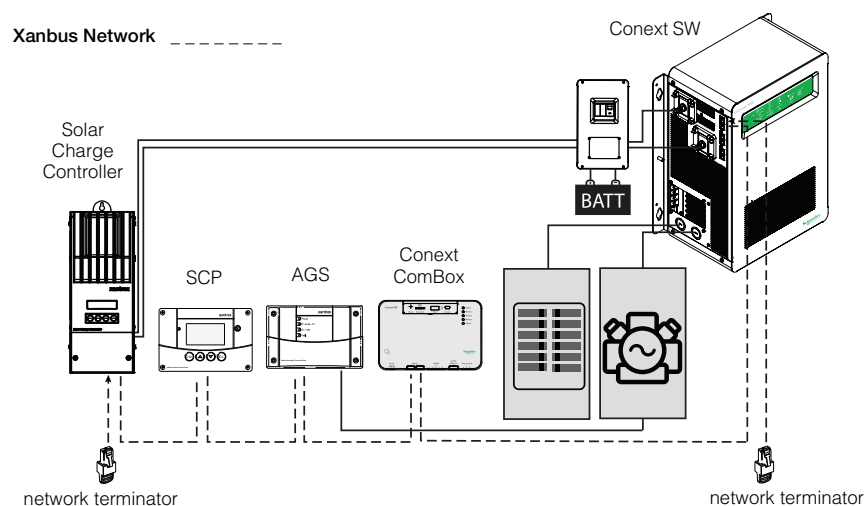

Figure 1-7 Xanbus System Diagram Example

The Xanbus-enabled designation (see below) means that this product works on a Xanbus network. Xanbus-enabled products are:

- Simple to operate and routine tasks are automated.
- Controlled by software that eliminates analog signalling errors.
- Less susceptible to interference and line loss.
- Upgradable through new software releases.

xanbus[™]
E N A B L E D

Xanbus-enabled Products and Other Accessories

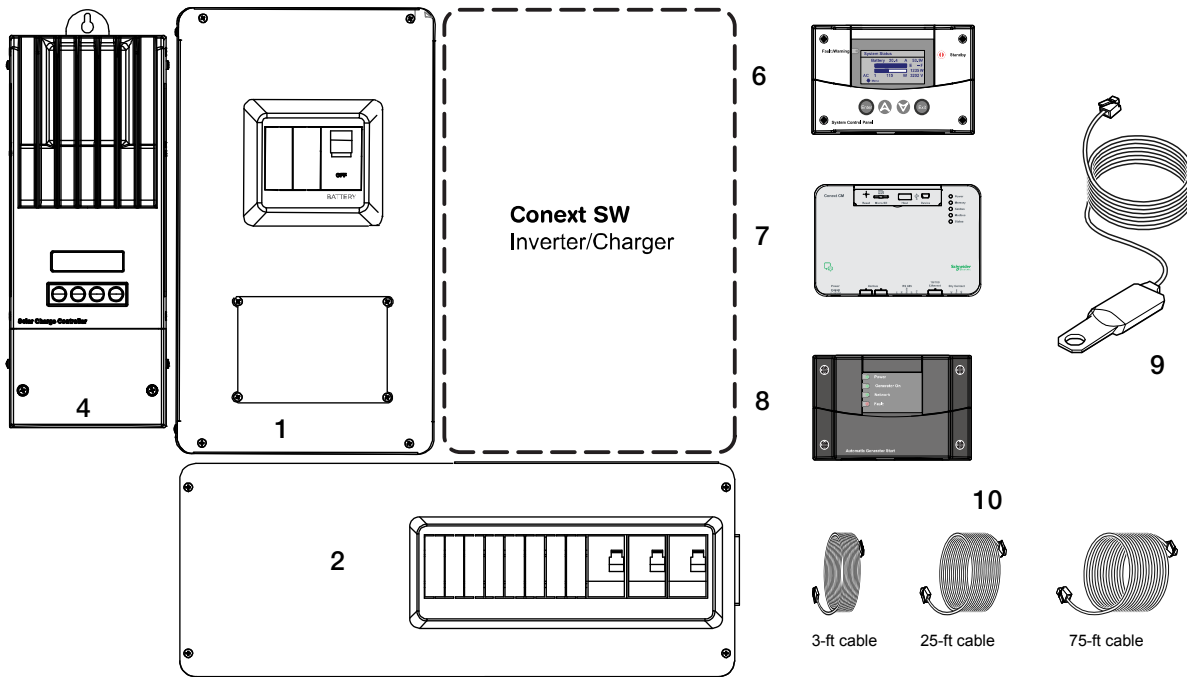

	Product/Accessory (Shown above)	Product Number/s
1	Conext SW DC Switchgear*	865-1016*
2	Conext SW AC Switchgear	865-1017
3	Stacking Kit (not shown)	865-1019
4	MPPT 60 150 Solar Charge Controller	865-1030-1
	MPPT 80 600 Solar Charge Controller (not shown)	865-1032
5	Conext SW On/Off Remote Switch (not shown)	865-1052
6	System Control Panel (SCP)	865-1050
7	Conext ComBox	865-1058
8	Automatic Generator Start (AGS)	865-1060
9	Battery Temperature Sensor (BTS)	808-0232-02
10	3-ft network cable (0.9 m)	809-0935
	25-ft network cable (7.6 m)	809-0940
	75-ft network cable (22.9 m)	809-0942

* required accessory for code-compliant installation in Canada and USA.

Installation Planning

Planning Preparations

This section provides information to help plan for a basic installation of the Conext SW. There are two key factors that will have a major impact on system performance.

1. Size and Length of DC Cables

To select the appropriate size and length of DC cables, see “DC Cabling” on page 1–14.

The DC cables should be as short as possible and large enough to handle the required current, in accordance with the electrical codes or regulations applicable to your installation. If there are long battery cables which are in excess of 3 meters each and not of sufficient size, the voltage drop across the cables will have a negative impact on overall system performance.

2. Mounting Location of the Conext SW

See “Step 1: Choosing a Location for the Inverter/Charger” on page 1–19.

Components of the Inverter Power System

Inverter power systems vary depending on the power requirements of the user and where the user is located. Inverter power systems typically involve one AC source, one DC source, one inverter/charger, and a control and monitoring device.

One example is an off the grid house with an AC generator, a battery, and a Conext SW inverter/charger with a System Control Panel (SCP). Another example is a house in the city, that is connected to the power grid but needs a power backup solution to cope with rolling blackouts during summer. Some power systems involve harvesting renewable energy such as solar energy in conjunction with off-grid or power backup solutions.

Before installing a Conext SW inverter/charger, know your power requirements then divide the components of the power system into AC, DC, and Xanbus network devices. Xanbus network devices control and monitor the Conext SW inverter/charger as well as AC generators and solar panels.

AC, DC, and Network Components

The illustration below shows the different components that can go into a Conext SW inverter/charger installation.

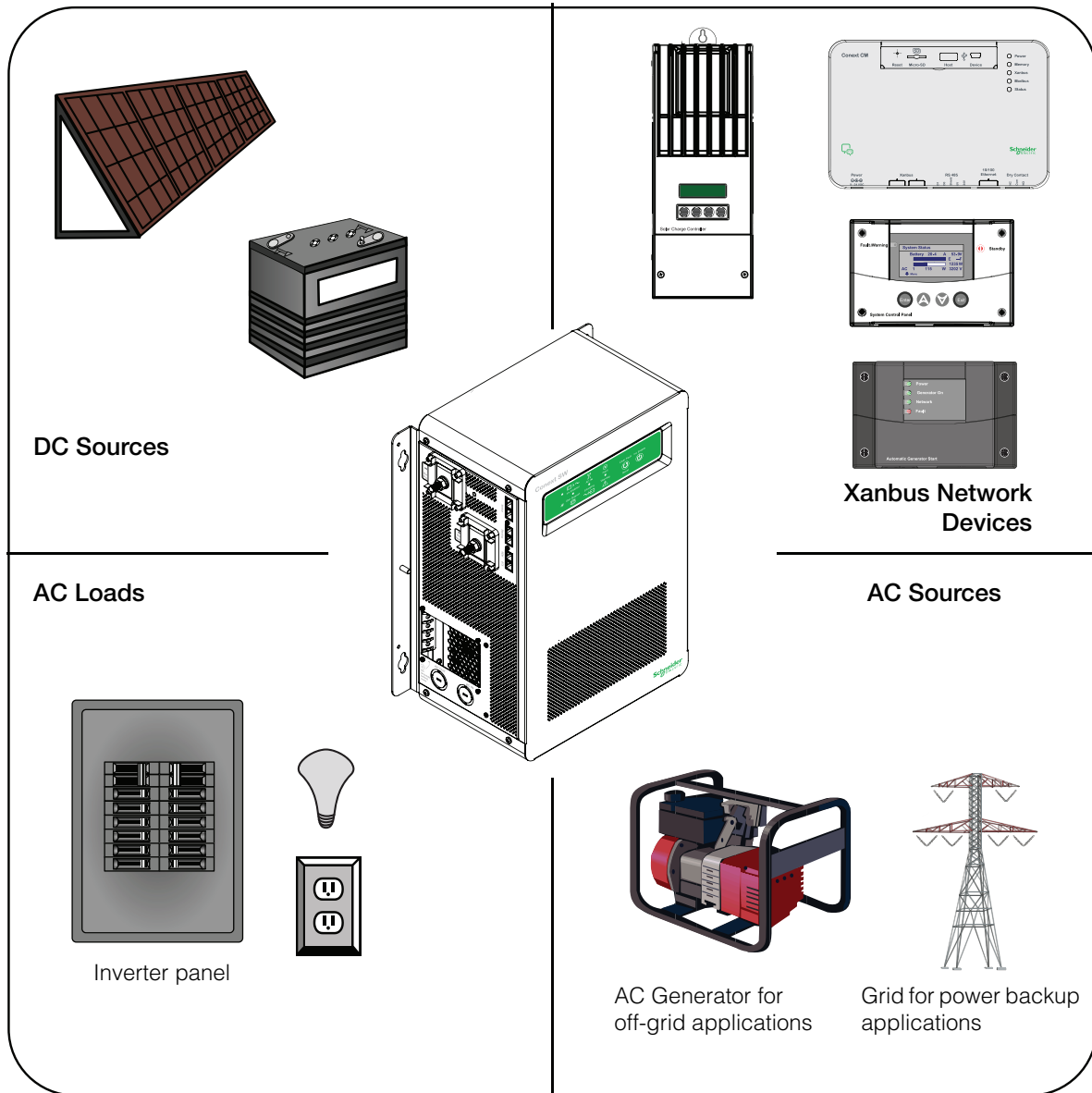

Figure 1-8 AC, DC, and Network Components

The illustration below shows which components you may need before you begin your installation.

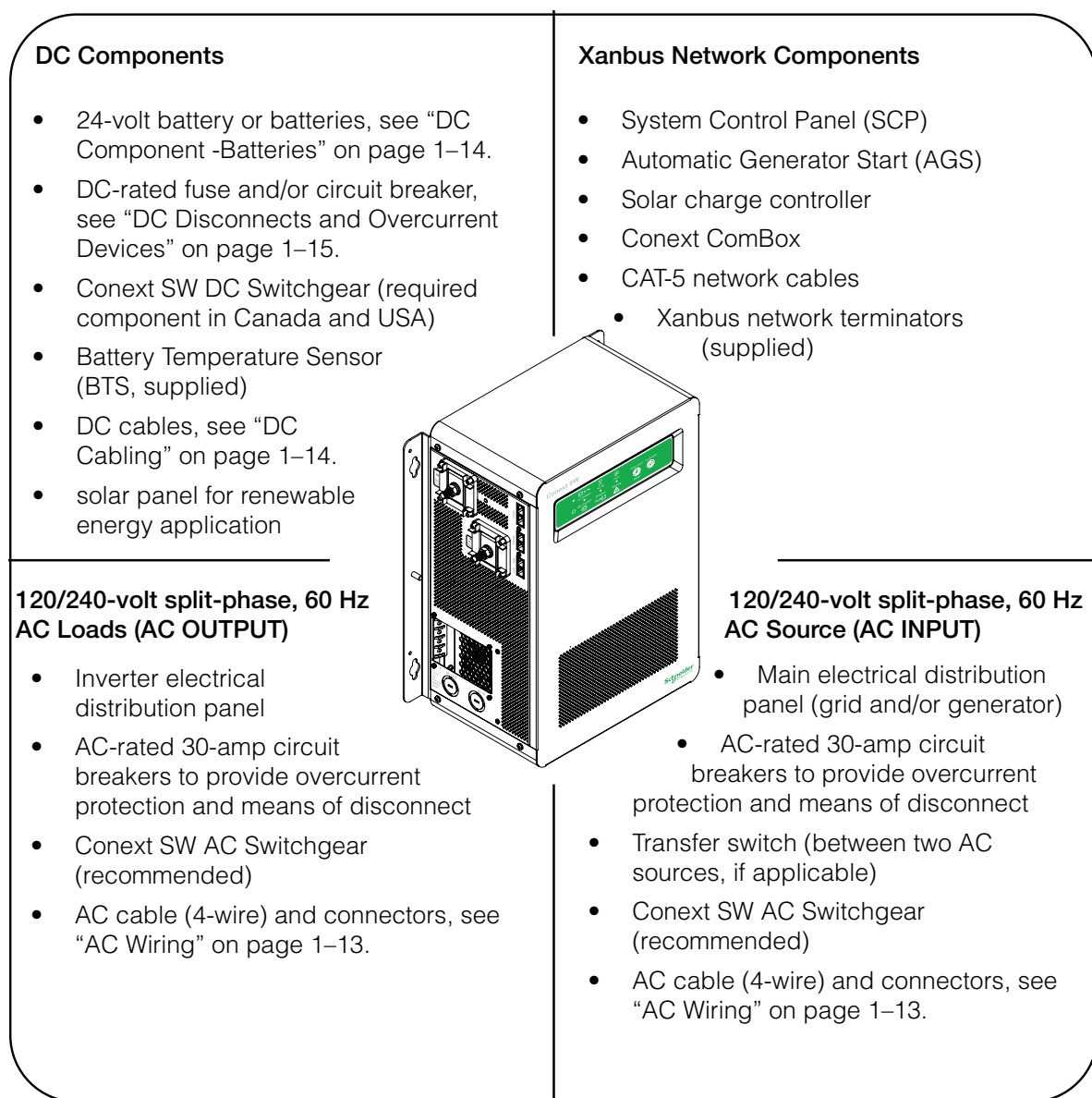

Figure 1-9 AC, DC, and Network Components

AC Wiring

Definition AC wiring includes input wiring (all the wires and connectors between the main AC source panel and the inverter/charger AC INPUT) and output wiring (all the wires between the inverter/charger AC OUTPUT and the AC load panels, circuit breakers, and loads).

Type The type of wiring required varies according to the electrical codes or regulations applicable to your installation. Wiring may be solid in multi-conductor cables, but stranded wire is required if single conductors are used. All wiring must be rated 90 °C or higher.

Size of AC Input Wiring Wire size must be coordinated with the overcurrent protection provided ahead of the wire involved, in accordance with the electrical codes or regulations applicable to your installation.

Therefore, the wiring used between the main AC source panel's circuit breaker and the inverter/charger AC INPUT must be sized to match the input breaker rating.

Table 1-1 AC Wire Size In and Out of the Inverter/Charger

	Conext SW
Breaker Size Used	30 amps per line
Wire Size	No. 8 AWG
Color Coding	L1/L2: red or black N: white or gray ⊕: green or bare

Size of AC Output Wiring Wire size must be coordinated with the current the wiring will carry. For example, this current may be determined by the 15-amp maximum inverter current, or by the bypass current, which is determined by the overcurrent protection provided ahead of the Conext SW 4024 120/240.

Size of Wiring Downstream of the AC Output Breaker The wiring used between the AC output breaker and your loads must be sized to match the output breaker.

DC Component - Batteries

The Conext SW system requires a 24-volt, lead-acid deep-cycle battery or group of batteries to provide the DC current that the inverter/charger converts to AC power. The battery may be a flooded, gel, or AGM type.

See “Battery Information” on page 1–37 for information on:

- Estimating the battery size that will meet your requirements.
- Designing battery banks.
- Restrictions on the size of appliances.

For information on cabling and hooking up batteries, see “Battery Cabling and Hook-up Configurations” on page 1–41.

For detailed information about specific brands of batteries, consult individual battery manufacturers or a local battery distributor.

DC Cabling

Definition DC cabling and connectors between the batteries, the DC disconnect and overcurrent protection device, and the inverter/charger.

Type All installations require multi-strand insulated cables. The DC cables must be copper and must sized based on 75 °C ampacity and must have an insulation rating of at least 75 °C.

Size and Length See Table 1-2 for required DC cable length, cable size and required fuse size for the Conext SW. Wire size is usually marked on the cables.

Table 1-2 Recommended Battery Cable Sizes^a

Model	Maximum Current (A)	Conduit ^b	
		Cable Length < 5 ft (1.5 m)	Cable Length 5 to 10 ft (1.5 to 3 m)
SW 2524 120/240	120	1 AWG	
SW 4024 120/240	200	3/0 AWG	

a.From National Electrical Code (NEC) requirements.

b.Per NEC Table 310.16 for 177 °F (75 °C) rated copper conductor.

IMPORTANT: Using a smaller gauge cable or a longer cable may cause the inverter to shut down under heavy load.

⚠ WARNING

FIRE AND BURN HAZARD

Do not use battery cables that are insufficiently sized for expected current. Check local electrical codes carefully.

Failure to follow this instruction can result in death or serious injury.

DC Disconnects and Overcurrent Devices

The DC circuit from the battery to the inverter/charger must be equipped with a disconnect and overcurrent protection device. Refer to your applicable installation code.

TypeThis device usually consists of a circuit breaker, a “fused-disconnect,” or a separate fuse (installed at each positive cable near the battery terminal) and DC disconnect. Do not confuse AC circuit breakers with DC circuit breakers. They are not interchangeable.

RatingThe rating of the fuse or breaker must be matched to the size of cables used in accordance with the applicable installation codes.

LocationThe breaker or fuse and disconnect should be located as close as possible to the battery in the positive cable. Applicable codes may limit how far the protection can be from the battery.

Table 1-3 Recommended Fuse and Breaker Sizes

Model	Fuse Size (A)	Minimum Breaker Size (A)
SW 2524 120/240	250	250
SW 4024 120/240	250	250

Conext SW DC Switchgear

The DC Switchgear (part number: 865-1016) provides complete DC disconnect and overcurrent protection for the Conext SW Inverter/Charger. The Conext DC Switchgear contains a master DC breaker that stops DC power from the main DC source. The DC Switchgear must be installed with the Conext SW Inverter/Charger in Canada and USA.

Unpacking and Inspecting the Conext SW Inverter/Charger

▲ CAUTION

HEAVY LOAD HAZARD

Do not lift the unit by yourself. Use two people to lift and mount the unit. Always use proper lifting techniques during installation to prevent injury.
--

Failure to follow these instructions can result in injury.

To unpack and inspect:

Important: Keep the carton and packing material in case you need to return the Conext SW for servicing.

1. Unpack the unit and check the materials list. If anything is missing from the shipping box, contact your local Schneider Electric customer service representative. See page ii for information.
2. Record the serial number of the Conext SW and other purchase information in the beginning section under Information About Your System of the *Conext SW Inverter/Charger Owner's Guide*.
3. Save your purchase receipt to use as proof of purchase. This receipt is required if the inverter/charger requires warranty service.
4. Save the original shipping carton and packing materials. If the inverter/charger needs to be returned for service, it should be shipped in the original carton. Packing the Conext SW in the original shipping carton is also a good way to protect the inverter/charger if it ever needs to be moved.

Installation Tools and Materials

Tools

You will need the following tools to install the Conext SW and the battery temperature sensor.

- Wire stripper
- Crimping tools for fastening lugs and terminals on DC cables
- Phillips screwdriver: #2
- Slot screwdriver (1/4" [6mm] wide blade max.)
- Needle-nose pliers
- Wrench for DC terminals and Installation bracket: 5/16" and M6
- Power drill/driver

Materials

You will need the following materials to complete your installation:

- DC Switchgear
- Strain-relief clamp(s) for AC cables (not provided): 3/4" and/or 1"
- DC battery cables sized according to Table 1-2 on page 1–15
- Terminals and/or crimp connectors for DC cables (3/8" [9.5mm] stud size)
- AC and DC disconnect switches and overcurrent protective devices and connectors as required. See page 1–14
- AC output and input wire. See "AC Wiring" on page 1–13
- If the AC ground wire is stranded, each ground wire requires a ring terminal
- Four M6 nuts to secure the unit to the installation bracket (supplied)
- Four #12 (or equivalent) screws or bolts to mount the installation bracket to the wall
- Four #10 (or equivalent) screws for securing the DC Switchgear to the installation bracket

Inverter/Charger Installation

Overview

This section provides detailed information on installing the Conext SW. The overall procedure is divided into seven steps:

Step 1: Choosing a Location for the Inverter/Charger on page 1–19,

Step 2: Mounting the Inverter/Charger on page 1–19,

Step 3: Connecting the AC Input and AC Output Wires on page 1–21,

Step 4: Installing the DC Switchgear and Connecting the DC Cables on page 1–23,

Step 5: Connecting the BTS and Xanbus-enabled Components on page 1–28.

Step 6: Performing Checks Prior to Initial Start-Up on page 1–30, and

Step 7: Testing Your Installation on page 1–30.

Step 1: Choosing a Location for the Inverter/Charger

⚠ WARNING

FIRE HAZARD

For indoor use only. Do not install and/or operate in compartments containing flammable materials or in locations that require ignition-protected equipment.

Do not cover or obstruct the ventilation openings. Do not install this unit in a compartment with limited airflow.

Failure to follow these instructions can result in death or serious injury.

The inverter should only be installed in a location that meets the following requirements:

Dry	Do not allow water or other fluids to drip or splash on the inverter/charger. Do not expose to rain, snow or water.
Cool	Normal ambient air temperature should be between 32 °F and 77 °F (0 °C and 25 °C).
Close to battery but not in the same compartment	The length and size of your DC cables will affect performance. Use the DC cables recommended in Table 1-2 on page 1–15. The unit should not be installed in the battery compartment due to the possible presence of explosive hydrogen gas from the batteries.
Clearance	Allow as much space around the inverter/charger as possible. It is recommended that other objects and surfaces be at least 10" (254 mm) away from the ventilation openings for best performance.

Step 2: Mounting the Inverter/Charger

⚠ CAUTION

HEAVY LOAD HAZARD

- Do not lift the unit by yourself. Use two people to lift and mount the unit. Always use proper lifting techniques during installation to prevent injury.
- Make sure that the wall can support a load of up to 155 lbs. (70 kilos) for a two-unit stacked configuration.
- Do not install in drywall using drywall anchors. Attach the unit to wall studs. Use appropriately sized screws.

Failure the follow these instructions can result in injury.

IMPORTANT: Mount the inverter/charger before connecting any wires or cables.

TIP: Align the mounting holes in the center of wall studs. If necessary, fasten a plywood board first to a wall with non-standard-spaced wall studs. Then mount the inverter/charger on the plywood board.

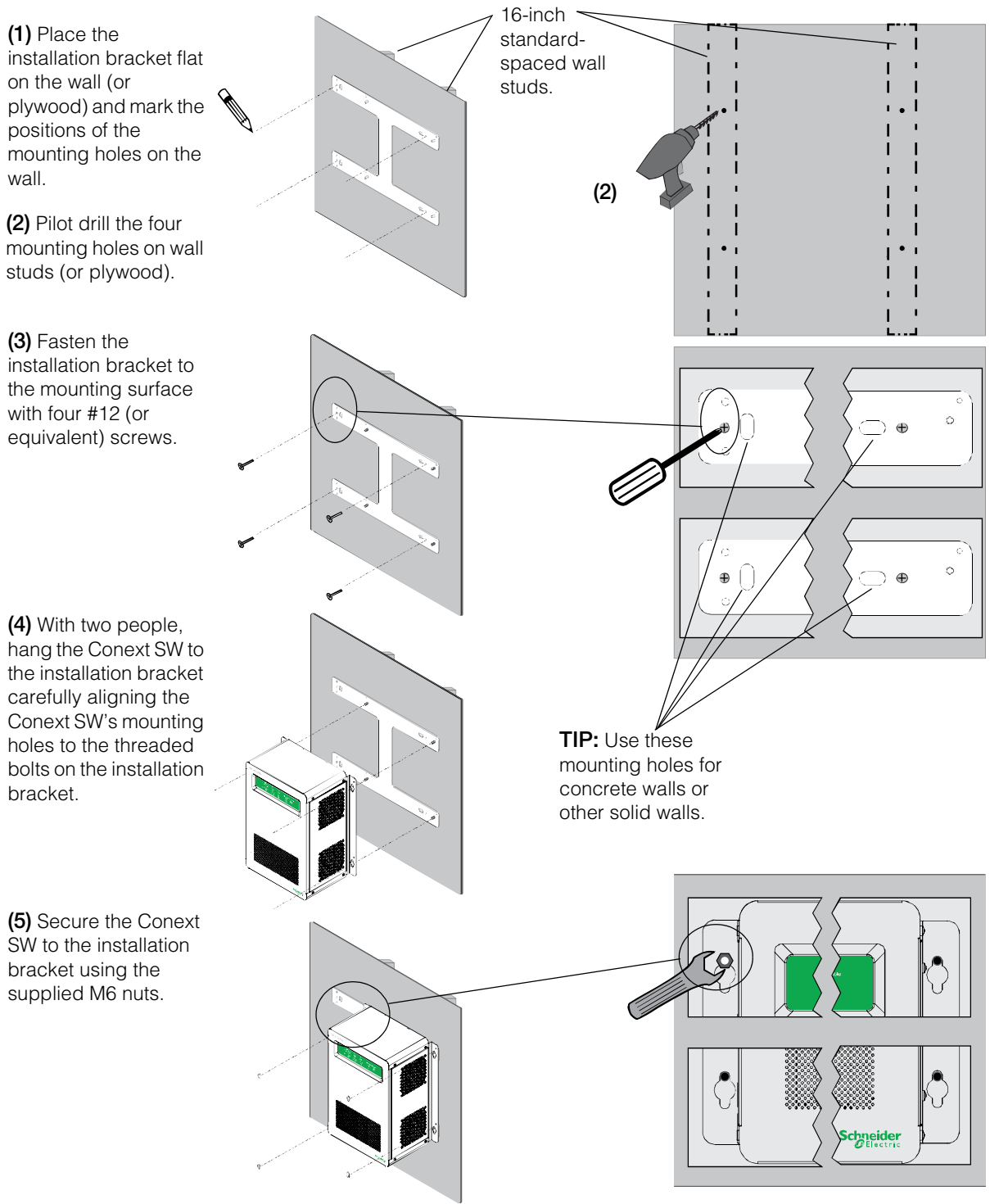

Figure 1-10 Conext SW Mounting Instructions

Step 3: Connecting the AC Input and AC Output Wires

⚠ DANGER

ELECTRICAL SHOCK AND FIRE HAZARD

Make sure wiring being connected to the inverter/charger is disconnected (physically or by opening and locking out the breaker) from all electrical sources before handling. All wiring must be done in accordance with local and national electrical wiring codes.

Failure to follow these instructions will result in death or serious injury.

General AC Wiring Considerations

AC and DC Wiring Separation Do not mix AC and DC wiring in the same conduit or panel. Consult the applicable installation code for details.

AC Knockouts There are two dual 3/4" /1" trade-size knockouts on the side panel and another two on the bottom panel for AC wiring. Use the same trade size of strain relief as the trade size of the knockout(s) you are using.

AC Wiring Terminals The AC wiring terminals accept cables of a specific size. See "AC Wiring" on page 1–13 for required sizes.

NOTICE

EQUIPMENT DAMAGE

Do not mix input and output wires. The terminal block is split into INPUT and OUTPUT sections. Damage may occur if the unit is wired incorrectly.

Failure to follow these instructions can damage the inverter/charger.

⚠ WARNING

ELECTRICAL SHOCK AND FIRE HAZARD

Turn off all electrical sources (by opening and locking out main and inverter panel breakers) before connecting wires to and from the inverter/charger. All wiring must be done in accordance with local and national electrical wiring codes.

Failure to follow these instructions can result in death or serious injury.

NOTE: Make the connections to the AC INPUT side first (steps (3) to (8)) then the AC OUTPUT side (steps (4) to (9)). Finish with step (10).

(1) Make the wiring connections to the AC source main panel.

(2) Route the AC cable to the inverter/charger.

(3) Remove the wiring compartment cover panel on the inverter/charger.

(4) Remove the AC knockouts from the side or bottom (or both). Do not leave the knockout inside the wiring compartment.

(5) Install a strain-relief clamp in the AC knockout.

(6) Route the AC cable through the AC knockout and inside the wiring compartment.

(7) Connect Line 1 to **L1**, Line 2 to **L2**, Neutral to **N**, ground to \oplus . If solid ground wire is being used, the wire can be connected directly under the screw heads. If stranded ground wire is being used, ring terminals must be used.

(8) Tighten the terminal screws. Leave a service loop in the wires inside the wiring box.

(9) Make the wiring connections to the inverter load panel.

(10) Replace the wiring compartment cover panel on the inverter/charger.

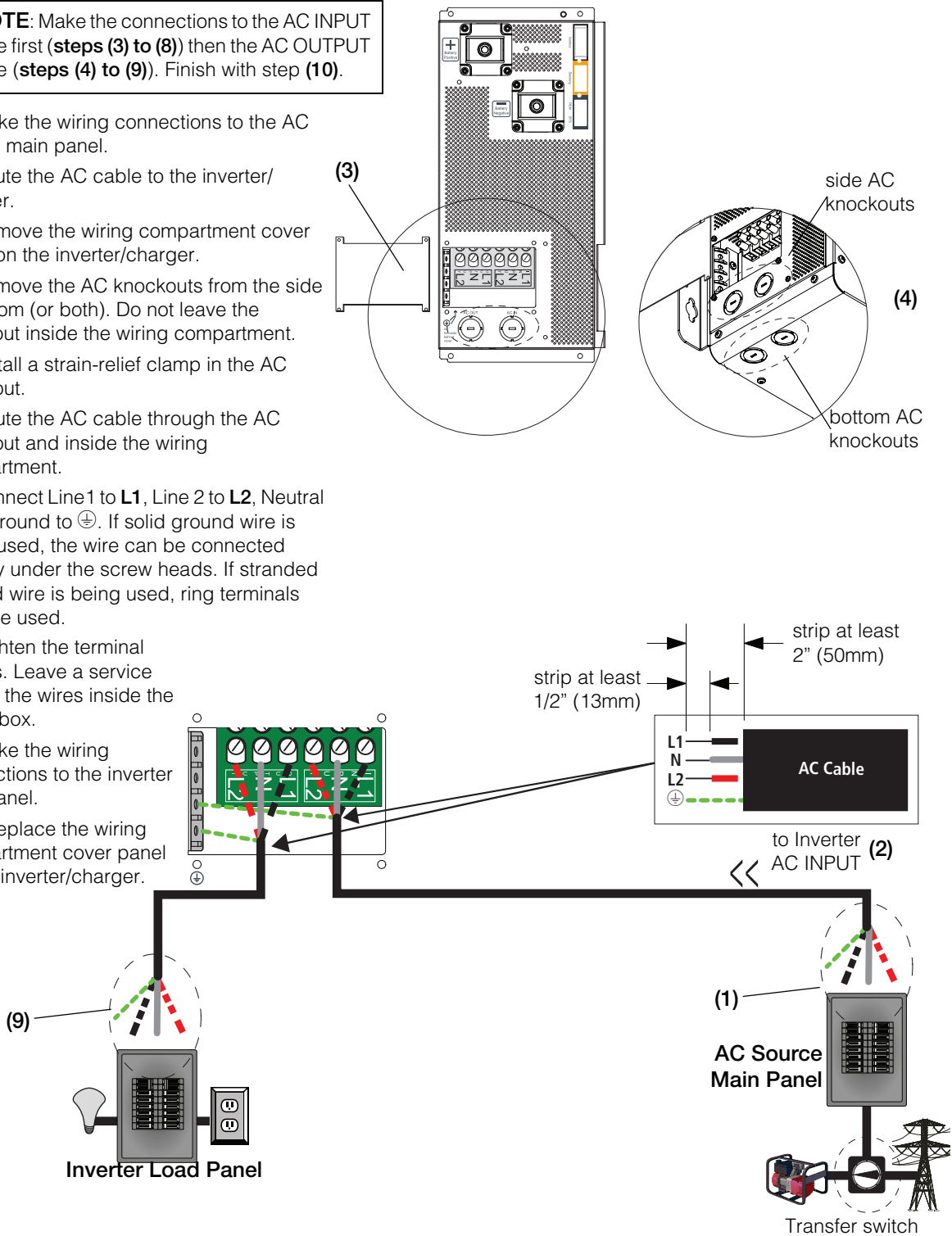

Figure 1-11 Conext SW AC INPUT and OUTPUT Connections

Step 4: Installing the DC Switchgear and Connecting the DC Cables

DC Connection Precautions

⚠ WARNING

ELECTRICAL SHOCK HAZARD

Connect and disconnect DC wiring only after opening and locking out the disconnect switches or breakers at all AC and DC sources.

Failure to follow these instructions can result in death or serious injury.

Recommended Cable Sizes and Lengths and Fuse Size

For recommended DC cables and fuse sizes, see Table 1-2 and Table 1-3 on page 1–15.

Preparing the Cables

Cut the negative and positive cables to the required length. Strip off enough insulation so you can install the terminals you will be using.

Use of crimp connectors – The connector should have a 3/8" stud size to connect to the Conext SW. If a crimp connector is used, it should be crimped using the tool indicated by the connector manufacturer.

Attach the connectors to the ends of both cables. Make sure no stray wire strands protrude from the connectors.

Guidelines for Routing the DC Cables

Follow these guidelines to ensure maximum performance.

⚠ WARNING

ELECTRICAL SHOCK AND FIRE HAZARD

Route the cables away from sharp edges that can cut into or scrape the insulation. Wires can become exposed. Avoid sharp bends in the cable.

Failure to follow these instructions can result in death or serious injury.

- To reduce the chance of radio frequency interference, keep the positive and negative cables close together—ideally, held together by straps, loom, or insulated clamps at regular intervals.
- To ensure maximum performance from the inverter/charger, do not route your DC cables through a DC distribution panel, battery isolator, or other device that will cause additional voltage drops. The exception is the DC fuse and Disconnect or the DC circuit breaker which is required at the battery to protect the DC wiring.
- To help avoid damage caused by reverse polarity battery connection, it is a good idea to mark each end of each cable to identify it as a positive (red) or negative (black) cable before routing the wiring.

Installing the DC Switchgear next to Conext SW Inverter/Charger

⚠ WARNING

FIRE HAZARD

- Make sure the supplied nuts on the inverter/charger are tightened to a torque of 10–11 ft-lbs (13.5–14.9 Nm). Torque all other connections to the manufacturer's specifications.
- Make sure the bus bar, washer, and nut are assembled in the order shown in Figure 1-12 on page 1–25..

Failure to follow these instructions can result in death or serious injury.

- (1)** Unpack the DC Switchgear from its box, if not already.
- (2)** Prepare four #10 (M5) machine screws. Use two screws to secure the DC Switchgear to the installation brackets of the Conext SW and two screws to secure the connecting bracket. The connecting bracket attaches to the Conext SW and DC Switchgear.
- (3)** Remove the nuts and washers from the inverter/charger's DC terminals, if present.
- (4)** Position the DC Switchgear next to the inverter/charger carefully aligning the mounting holes with the pre-cut mounting holes on the installation bracket and the copper bus bar connectors with the inverter/charger's DC terminals.
- (5)** Fasten the screws to the mounting holes on the DC Switchgear with the pre-cut mounting holes on the installation bracket of the inverter/charger.
- (6)** Fasten the screws to the connecting bracket to join the DC Switchgear and the Conext SW together.
- (7)** Fasten the nuts and washers of the inverter/charger's DC terminal bolts to secure the copper bus bars.

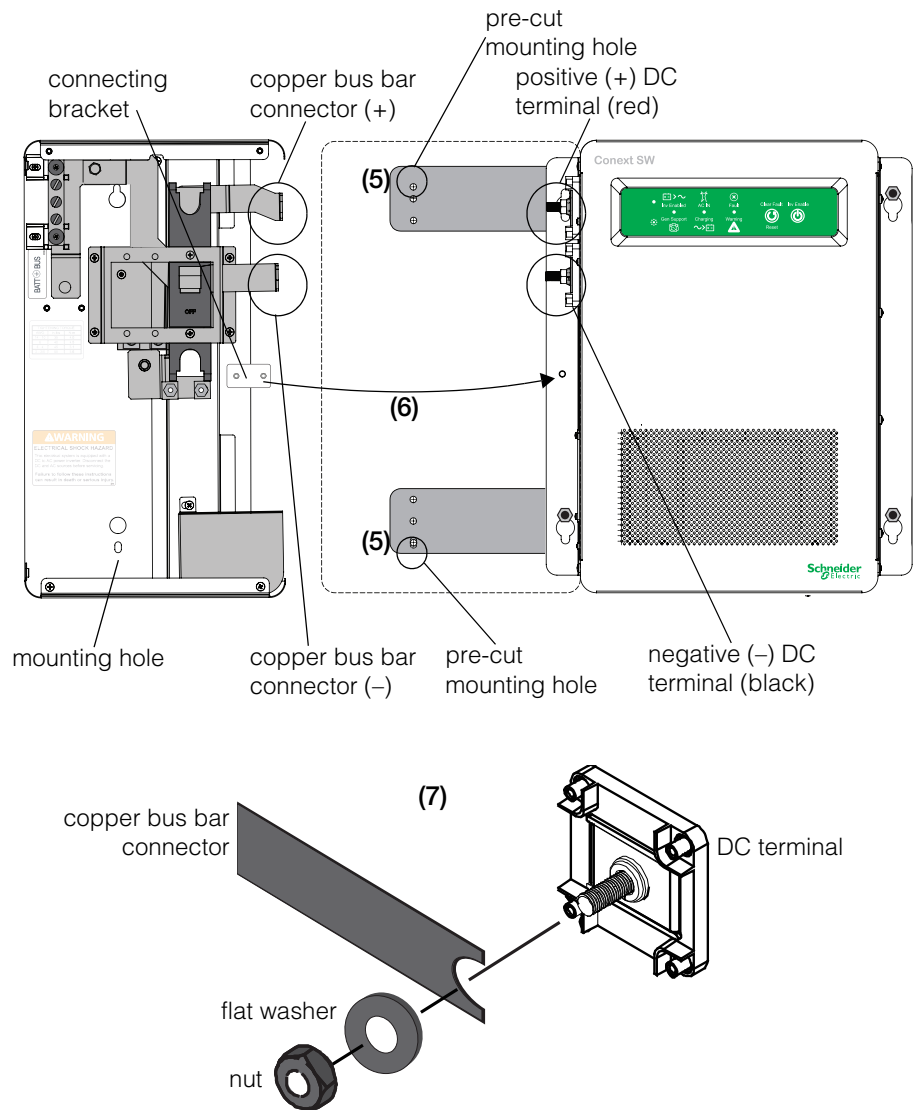

Figure 1-12 Installing the DC Switchgear

Connecting the DC Cables to the DC Switchgear

⚠ WARNING

FIRE HAZARD

- Use only appropriately sized copper cable. Loose connections, improper connections, and under-rated cables will overheat.
- Make sure the supplied nuts on the inverter/charger are tightened to a torque of 10–11 ft-lbs (13.5–14.9 Nm). Torque all other connections to the manufacturer's specifications.
- Make sure the DC cables, washers, and nuts are assembled in the order shown in Terminal Connection in Figure 1-13 on page 1–27.

Failure to follow these instructions can result in death or serious injury.

NOTICE

REVERSE POLARITY DAMAGE

Check cable polarity at both the battery and the inverter/charger before making the final DC connection or closing the DC breaker or disconnect. Positive (+) must be connected to positive (+). Negative (–) must be connected to negative (–).

Failure to follow these instructions can damage the inverter/charger.

- (1) Route the DC cables from the battery bank to the DC Switchgear.
- (2) Install a DC fuse (a) on the positive cable near the battery terminal.
- (3) Open the DC circuit breaker on the DC Switchgear.
- (4) Connect one connector on the POSITIVE (+) cable to the POSITIVE terminal on the DC Switchgear. The connector goes on first, then the flat washer (steel), then the 3/8" (9.5mm) bolt (brass).
- (5) Connect the other connector to the POSITIVE (+) terminal on the battery.
- (6) Connect one connector on the NEGATIVE (-) cable to the BATTERY NEGATIVE terminal on the DC Switchgear.
- (7) Connect the other end of the cable to the NEGATIVE (-) terminal on the battery.

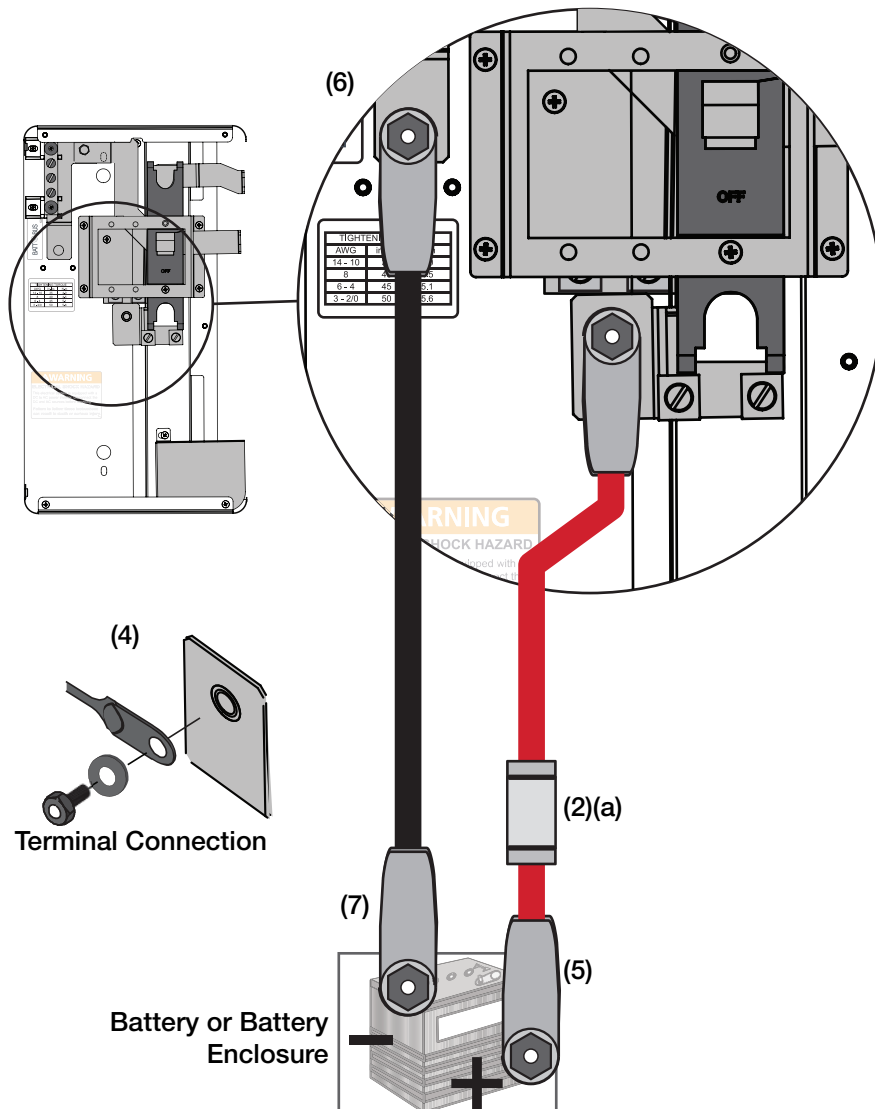

Figure 1-13 Conext SW DC Connections

Step 5: Connecting the BTS and Xanbus-enabled Components

⚠ WARNING

ELECTRICAL SHOCK HAZARD

Connect and disconnect DC wiring only after opening and locking out the disconnect switches or breakers at all AC and DC sources.

Failure to follow these instructions can result in death or serious injury.
--

**Battery
Temperature
Sensor (BTS)**

Installing a BTS extends the life of a battery by preventing overcharging in warm temperatures and undercharging in cold temperatures. With a BTS monitoring the battery temperature, the voltage delivered to the battery is adjusted according to the battery's actual temperature.

The BTS has a self-adhesive backing and attaches to the side of the battery. The BTS also comes with a metal tab. A 25-ft (7.6-m) cable is supplied with the BTS.

**Xanbus-enabled
Components**

These include the SCP, the AGS, Conext ComBox, and a solar charge controller. The order in which the components are connected to the inverter/charger does not matter. The most important aspect of the installation of these components is the attachment of network terminators at each end of the network.

(1) Install the BTS sensor on the battery.

Method **(a)** involves mounting the sensor to the negative battery post which allows the internal battery temperature to be sensed providing the most accurate results.

Method **(b)** attaches the sensor to the side of the battery using the self-adhesive backing which also provides good results in most situations.

(2) Plug the BTS connector to the BTS port of the inverter/charger.

(3) Connect the Xanbus-enabled devices using the provided network cable. Terminate each end of the network with a network terminator **(c)** and **(d)**.

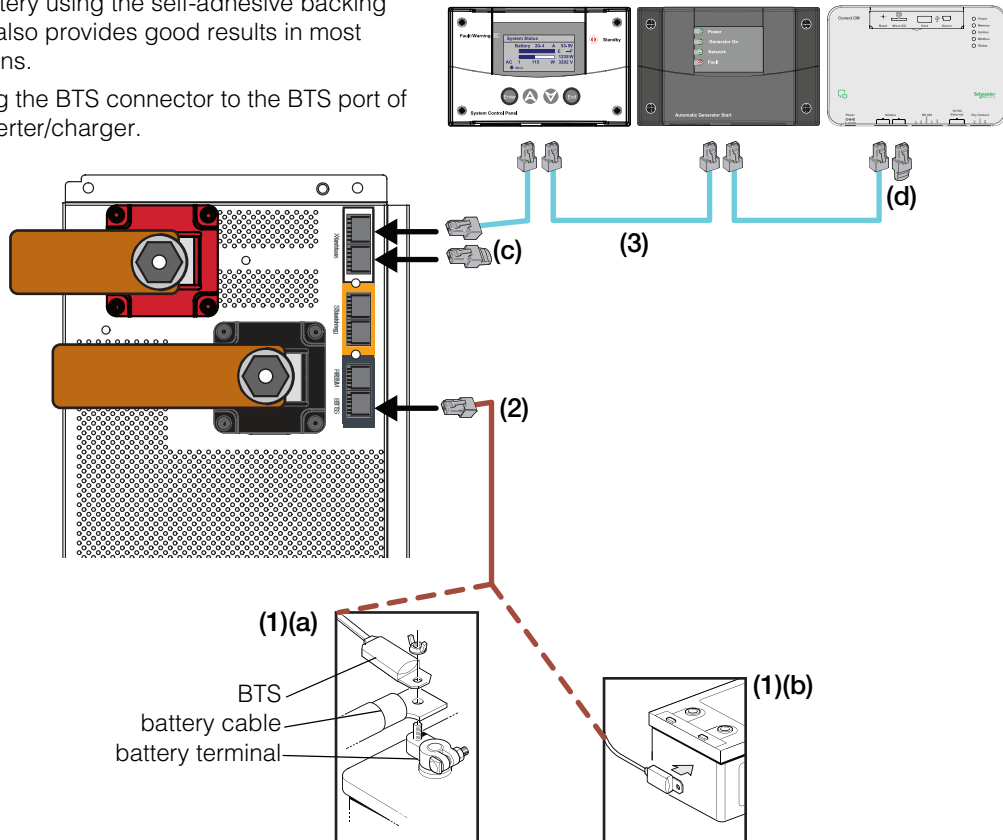

Figure 1-14 Conext SW BTS and Xanbus Connections

Step 6: Performing Checks Prior to Initial Start-Up

Before testing your installation, ensure these conditions are met.

- AC ground are properly installed.
- AC input connections and AC output connections are wired correctly on the terminal block and not reversed.
- Positive (+) battery cable from the DC Switchgear is connected to the positive (+) battery terminal through the DC fuse.
- Negative (-) battery cable from the DC Switchgear is connected to the negative (-) battery terminal.
- Battery voltage is within the proper range for this unit: 20–34 volts DC.
- DC disconnect switch or breaker is turned off.
- AC input and output breakers are turned off.
- All connections are tight.

Step 7: Testing Your Installation

⚠ WARNING

ELECTRICAL SHOCK HAZARD

The Inv Enable button on the Conext SW front panel and the SCP do not disconnect DC or AC input power to the Conext SW. Isolate energy by turning off and locking out all AC and DC circuit breakers and test with a multimeter before checking or tightening electrical connections.

Failure to follow these instructions can result in death or serious injury.

There are several tests to be performed for testing your installation. These tests will verify that:

- The Conext SW works in invert mode.
- The Conext SW works in charge mode.
- The Conext SW works in AC bypass mode.

If the test fails at any point, go to “Step 6: Performing Checks Prior to Initial Start-Up” on page 1–30 and go through the checklist again to check the installation. Then perform the test again. If the test fails again, see the troubleshooting section in the Conext SW Inverter/Charger Owner’s Guide.

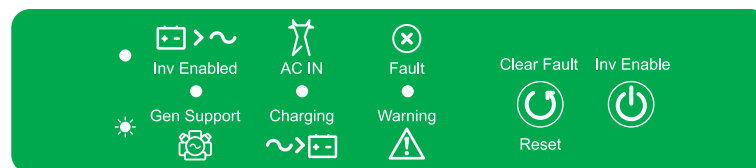

Figure 1-15 Conext SW Front Panel

Testing in Invert Mode

To test the Conext SW in invert mode, using a 100 watt light bulb as the test load:

1. Close the DC disconnect switch or the DC circuit breaker to supply DC power to the Conext SW.
Wait for the LEDs on the front panel to flash on and off, indicating that the unit is successfully initializing (10 to 30 seconds). The LEDs will turn off after initialization.
If none of the LEDs come on or flash intermittently, make sure the voltage at the DC terminals on the Conext SW is correct, as described in "Step 6: Performing Checks Prior to Initial Start-Up" on page 1–30.
2. After initialization, observe that none of the lights on the front panel should remain illuminated.
3. Press the Inv Enable button. Verify that the green Inv Enabled LED illuminates.
4. Connect the Conext SW to the test load by closing the AC breaker that controls the circuit that the test load is connected to.
If the light bulb illuminates, the Invert mode is working.
5. Press the Inv Enable button to disable inverter mode. The Inv Enabled LED goes off.

Testing in Charge Mode and AC Bypass Mode

1. Start the AC generator, if off-grid. If grid-connected proceed to step #2.
 2. Close the main breaker in the AC input panel (the AC input panel feeds power from either the generator or grid) in order to supply AC power to the unit.
- Verifying charging:**
3. After a few seconds, verify that the AC IN / Charging LED on the front panel is turned on and that it starts flashing indicating that the batteries are being charged.
- Verifying AC bypass:**
4. Disable the AC source by opening the main breaker in the AC input panel and turn off inverter mode by pressing the Inv Enable button.
 5. Connect the test load to the AC output connection of the unit.
 6. Enable the AC source by closing main breaker in the AC input panel and the test load should turn on after ten seconds.

Installation Complete

Your installation is now complete. The inverter/charger is ready for use.

The preceding tests use a light test load (a light bulb) as a test case. If you encounter problems when using a load over 1000 watts (for example, a hair dryer or microwave), see the troubleshooting information in the Conext SW Inverter/Charger Owner's Guide.

Multiple Unit Configuration

The Conext SW inverter/chargers support multiple unit configuration to increase power output. This gives the system engineer and/or installer more options to work with when tailoring a system to meet load demands.

In a multiple unit configuration, only two Conext SW inverter/chargers of the same model can be used. For example, two Conext SW 4024 120/240 units can be configured because both units each have a 24-volt rating and a continuous power rating of up to 3500 watts.

In this configuration, the inverter and charger capacity of a system is doubled. In the case of two Conext SW 4024 120/240 units, the inverter power rating doubles to 7000 watts and the charging output current doubles to 180 amps. However, the AC transfer relay rating of 30-amps remains the same. Inverter/chargers can operate from different battery banks, meaning each unit is connected to its own battery bank. However, it is highly recommended to use only a single battery bank. See “DC Connections for Multiple Unit Configuration” on page 1–33.

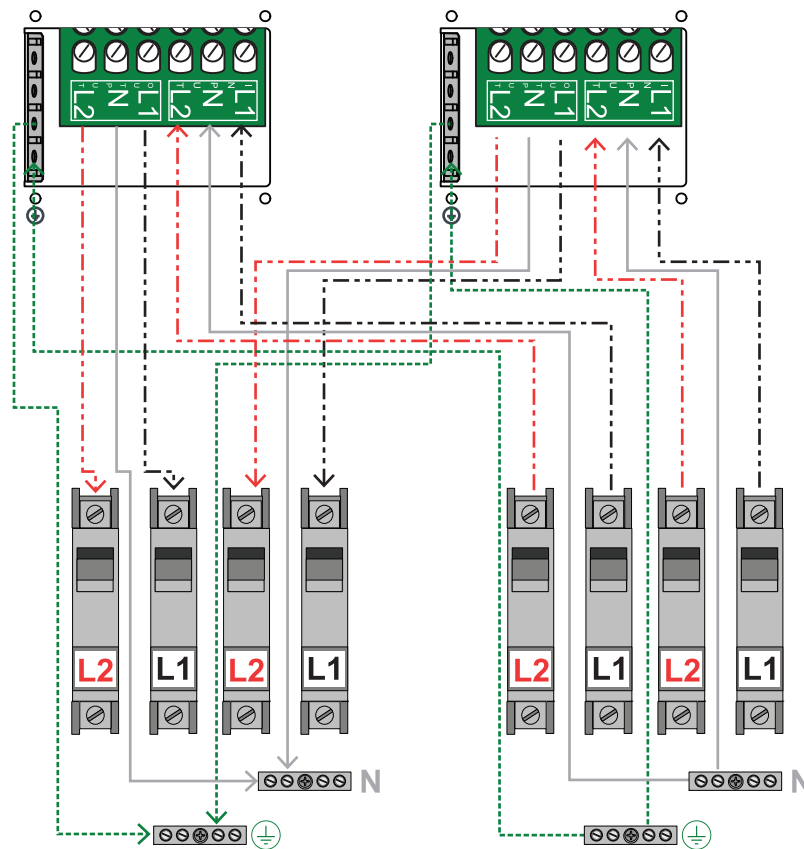

Figure 1-16 Multiple Unit Configuration Using Two Conext SW Units

DC Connections for Multiple Unit Configuration

Individual overcurrent devices are to be used between the battery positive and each positive cable leading to the DC Switchgear. Keep cable lengths to the two DC switchgears the same in order to balance cable losses.

Connect the units as follows:

1. Connect the positive cables.
Follow the steps in “Connecting the DC Cables to the DC Switchgear” on page 1–26.
Also, do not tie the positives in series together between inverters.
2. Connect the negative cables.
Follow the steps in “Connecting the DC Cables to the DC Switchgear” on page 1–26.
3. Connect the battery temperature sensors (BTS), if needed.
Follow the steps in “Step 5: Connecting the BTS and Xanbus-enabled Components” on page 1–28.

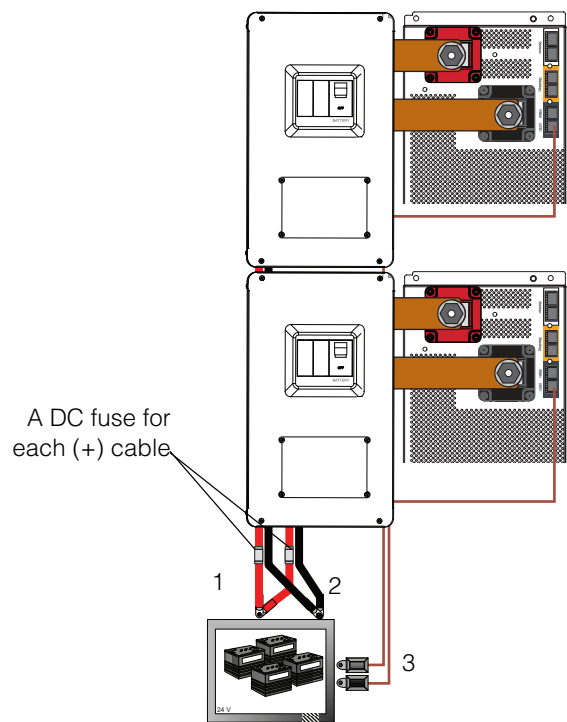

Figure 1-17 Connecting Battery Cables

Neutral Wiring for Inverters in Multiple Unit Configuration

In a multiple unit configuration, connect the two AC input neutrals together at the main distribution panel and the two AC output neutrals at an isolated neutral location in the inverter AC distribution panel.

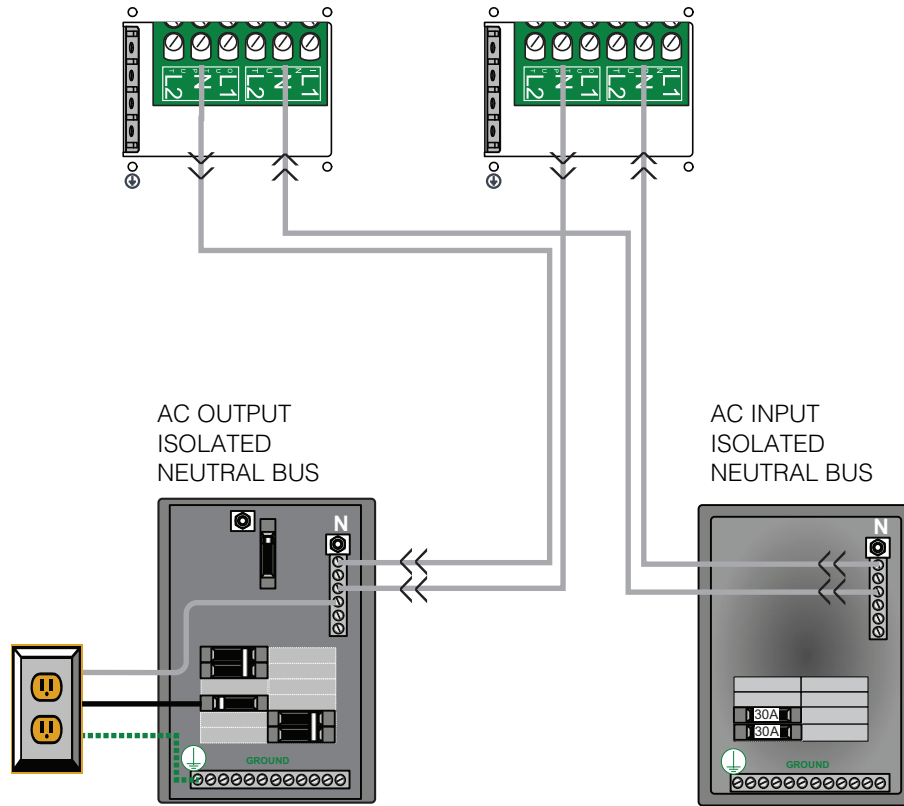

Figure 1-18 Neutral Wiring for Multiple Unit Configuration

IMPORTANT: In a multiple unit configuration where two Conext SW units are set up together, the AC transfer relay rating remains the same at 30 amps. This AC transfer relay rating does not double to become 60 amps.

⚠ WARNING

FIRE HAZARD

Do not power multiple loads in excess of 30 amps even in a multiple unit configuration.

Failure to follow this instruction can result in death or serious injury.

Configuring the System for Multiple Unit Operation

Verify all DC and AC connections. Check Xanbus network connections and ensure that terminators are installed at devices at each end of the network. The simplest system includes a Xanbus SCP, the two multi-unit-configured Conext SW inverter/chargers, and two Xanbus terminators.

For both units to operate in multiple unit configuration, a Master and Slave have to be assigned. The default out-of-box configuration for all Conext SW inverter/chargers is **Master** which causes a conflict the first time the system is powered up. The installer will need to change configuration on one of the inverter/chargers to **Slave** mode.

To configure the system for multiple unit configuration:

1. Apply DC power to both inverter/chargers.
Power up order has no impact. Because there are now two Master units in the system, the SCP will detect an **F71** fault, a “system configuration fault”.
2. From the SCP **System Status** screen, press **Enter**. The **Select Device** screen appears.
3. Select the inverter to configure as a Slave unit from the list, then press **Enter**.
4. Bring up the **Advanced Settings** screen by pressing **Enter**, Up, and Down arrow buttons all together.
5. Select **Advanced Settings** and press **Enter**. The Advanced Settings screen appears.
6. Scroll down to select **Multi Unit Config**.
At this point all devices in the system will be automatically placed in standby mode. All three LEDs on the inverter to be configured will start flashing

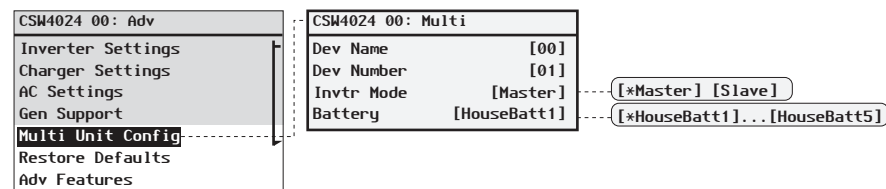

Figure 1-19 Multi Menu Screen

7. Select **Invtr Mode** and press **Enter**.
8. Select **Slave** and press **Enter**.
9. Press the **Exit** button repeatedly until the **System Status** screen appears.

NOTE: The only situation in which the Slave may shut down the Master inverter is during fault detection conditions such as high or low battery voltage, overcurrent, or over-temperature conditions. Both inverters will auto reset after a fault detection condition has been cleared. The exception is that an overcurrent condition will generate a shutdown for both inverters that will require a manual restart of the system.

Search Mode Operation in Multiple Unit Configuration

When two inverter/chargers are configured, search mode behavior on the Slave unit is modified and is dependent on how much total load is on the system.

Disabling Search Mode on the Master Unit

Search mode on the Master unit will not function properly. When the Master sends out a load search pulse, a small current also flows into the output of the Slave unit since the two outputs are in parallel. This Master unit falsely detects a load causing erratic search mode operation. For this reason, it is highly recommended to disable search mode on the Master unit.

Setting Search Mode on the Slave Unit

The Slave unit will behave in one of two ways depending on whether its search mode is enabled or disabled.

Search mode enabled This is the recommended mode which helps minimize battery draw. The Slave unit continuously monitors the output of the Master unit. If the Master unit has more than 60% of the rated load (for example, 2100 watts on SW 4024 120/240), the Slave unit will assist the Master and the two will share the load equally. Should the load on the Master drop below 20% of rated load (700 watts for SW 4024 120/240), the Slave unit disengages and returns to a waiting state.

Search mode disabled The Slave unit operates continuously along with the Master unit and shares the load.

Wiring Schematic

NOTE: Please refer to “Multiple Unit Configuration” on page 1–32 that shows the wiring schematic employed between two Conext SW inverter/chargers.

IMPORTANT: Follow the same guidelines in “Inverter/Charger Installation” on page 1–18 when choosing cables and/or wires for AC and DC connections.

⚠ WARNING
FIRE, ELECTRICAL SHOCK, AND EXPLOSION HAZARD
Make sure all wiring being used to make multiple unit configurations between inverter/chargers is disconnected (physically or by opening and locking out the breaker) from all electrical sources before handling. All wiring must be done in accordance with local and national electrical wiring codes.
Failure to follow these instructions will result in death or serious injury.

Battery Information

Battery Bank Sizing

Battery capacity Battery size or capacity is just as important as the battery type selected for use with the Conext SW. The batteries are the most important part of your system, so it is recommended that you purchase as much battery capacity as possible. A large battery will extend running time and ensure that your inverter/charger delivers full rated surge.

It is recommended to have a minimum battery size of 100 amp-hours (Ah) for moderate loads (<1000W) and greater than 200 Ah for heavy loads.

See “Estimating Battery Requirements” for information on a more detailed calculation.

About Amp-hours A number of different standards are used to rate battery energy storage capacity. Automotive starting batteries are normally rated in cranking amps. This is not a relevant rating for continuous loads like an inverter. Deep-cycle batteries use a more suitable rating system such as amp-hours (Ah).

Amp-hour capacity is the number of amps a battery can continuously deliver during a specified number of hours. It is represented by the product of the two —amps multiplied by hours.

A battery rated for 100 Ah can deliver 5 amps for 20 hours (5 amps × 20 hours = 100 Ah). This same battery can deliver a higher or lower current for less or more time, limited approximately by the 100 Ah figure (50 amps for 2 hours or 200 amps for 1/2 hour), but usually the capacity figure given is only accurate for the specified duration (20 hours).

Estimating Battery Requirements

Calculating Battery Size

Step 1: Compute Amp-hours

For each appliance, compute the number of amp-hours that will be used between charging cycles, as follows:

1. Obtain the wattage. If the wattage is marked on the nameplate rating, use that. Otherwise, multiply the marked voltage and amperage:
WATTS = VOLTS × AMPS.
2. Obtain the Watt-hours by multiplying that amount by the hours the appliance will be used:
WATT-HOURS = WATTS × HOURS.
3. Obtain the amp-hours that the appliance requires by dividing that amount by 20 (the factor for the Conext SW, which is a 24-volt system):
BATTERY AMP-HOURS USED = AC WATT-HOURS/20

For example, a 100 W light bulb that is used for 4 hours will use 400 watt-hours (Wh) and the inverter will consume approximately 20 Ah from a 24-volt battery.

4. Enter this information on the blank calculation worksheet (page 1–40).

Step 2: Calculate Battery Size

5. Complete the rest of the worksheet; see Table 1-4, “Battery Sizing Example” on page 1–39 for an example.

Size the batteries for approximately twice the estimated total amp-hour usage. Doubling the expected amp-hour usage ensures that the batteries will not be overly discharged and extends battery life.

Do not skip this doubling step. More capacity is better since you will have more reserve capacity, be better able to handle large loads and surge loads, and your battery won't be discharged as deeply. Battery life is largely dependent on how deeply the battery is discharged. The deeper the discharge, the shorter the battery life.

Troubleshooting If you find that the system shuts down when appliances with large motors are started, the problem may be that this motor is too much for the battery. Even though you calculated the amp-hour requirements appropriately, the startup of a large motor makes high demands on the battery. You may find that adding more amp-hours (in the form of extra batteries or replacement with a bigger battery) solves the problem.

Table 1-4 Battery Sizing Example

Appliance	(A) Power Consumption (Watts)	(B) Operating Time per Day (Hours)	Daily watt-hours needed for this appliance (= A × B)
TV & VCR	200 W	2 hours	400 Wh
Small microwave oven	800 W	15 min = 1/4 hour	200 Wh
3 lamps, 60 W each	180 W	4 hours	720 Wh
Coffee maker	600 W	15 min = 1/4 hour	150 Wh
Hair dryer	1500 W	6 min = 1/10 hour	150 Wh
Total daily watt-hours of AC load			1620 Wh
× Number of days between charges			3
= Total watt-hours of AC load between charges			4860 Wh
Battery Ah used between charges (divide by 20 for 24 volt system)			243 Ah
Recommended Battery Bank Size in Ah (multiply by 2)			486 Ah

This example illustrates how quickly your battery needs can escalate. To reduce the required battery bank size, you can either conserve energy by eliminating or reducing the use of some loads, or recharge more frequently.

Battery Banks

As your power requirements increase, you may need to use more than one battery to obtain sufficient capacity. Batteries can be connected in parallel, in series, or in series-parallel to create higher capacity systems.

See “Battery Cabling and Hook-up Configurations” on page 1–41 for more information about battery inter-connection schemes.

Mixing Batteries Batteries connected in parallel should be of the same type and amp-hour rating and from the same manufacturer.

It is not recommended to connect batteries of different types, amp-hour ratings or manufacturers. Improper charging and decreased battery life will result.

Battery Bank Sizing Worksheet

The following worksheet is a guide to help you determine your battery needs. Be generous in estimating the time for which you will run each of the loads to ensure sufficient battery capacity.

Restrictions on Motor Size

An appliance may require three to six times its normal running current in order to start. The Conext SW can handle surges up to twice its rated amount (surge current) for five seconds. For example, the model Conext SW 4024 120/240 is rated as having a maximum continuous output current of 15 amps and a surge capability of 32 amps. In motors, the locked rotor amp (also called its starting current) may be specified on the motor nameplate as “LRA” or “LRI”. The LRA must not exceed the surge current rating of 32 amps.

When considering appliances with large motors, follow these guidelines:

- Make sure that the motor's LRA rating is no more than surge current amps. The Conext SW may not be able to start a motor with a higher LRA, and the Conext SW will shut down if the attempt is made.
- Make sure the battery bank, DC cables and DC fuses are capable of handling up to 600 amps DC for five seconds. A weaker circuit may not be able to provide sufficient power to the Conext SW to allow the Conext SW to start up the appliance. Again, if the circuit cannot deliver the required current, the system may shut down or the fuse may open.

Table 1-5 Battery Sizing Worksheet

Appliance	(A) Power Consumption (Watts)	(B) Operating Time per Day (Hours)	Daily watt-hours needed for this appliance (= A × B)
	W	hours	Wh
	W	hours	Wh
	W	hours	Wh
	W	hours	Wh
	W	hours	Wh
	W	hours	Wh
	W	hours	Wh
	W	hours	Wh
Total daily watt-hours of AC load			Wh
× Number of days between charges			
= Total watt-hours of AC load between charges			Wh
Battery Ah used between charges (divide by 20 for 24 volt system)			Ah
Recommended Battery Bank Size in Ah (multiply by 2)			Ah

Battery Cabling and Hook-up Configurations

Several smaller batteries can be connected to create a battery bank of substantial size. You can connect batteries in three ways: in parallel, series, or series-parallel.

To make a larger battery bank, connect individual batteries with heavy cables. The actual size of the cable depends on whether the batteries are connected in parallel or series. Generally, the cable should not be smaller than the inverter cables—if the main cables are 4/0 AWG, the battery interconnects should be 4/0 AWG.

The best configuration is to connect the batteries in series and parallel. This requires additional cables, but reduces imbalances in the battery bank and can improve the overall performance. Consult your battery supplier for more information regarding the hook-up configuration required for your system.

Battery Parallel Connection

Batteries are connected in parallel when all the positive terminals of a group of batteries are connected and then, separately, all the negative terminals are connected. In a parallel configuration, the battery bank has the same voltage as a single battery, but an Ah rating equal to the sum of the individual batteries. See below.

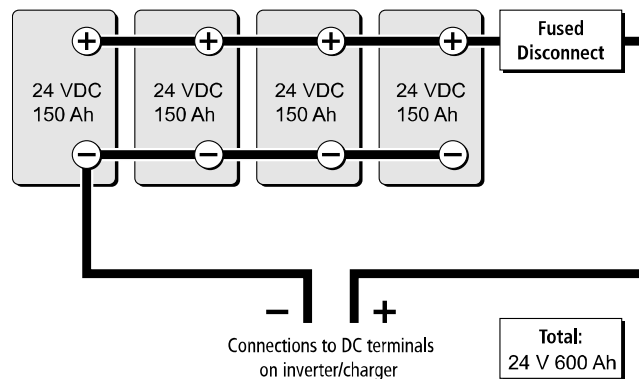

Figure 1-20 Batteries Connected in Parallel

Battery Series Connection

When batteries are connected with the positive terminal of one battery to the negative terminal of the next battery, they are connected in series. In a series configuration, the battery bank has the same Ah rating of a single battery, but an overall voltage equal to the sum of the individual batteries. See below.

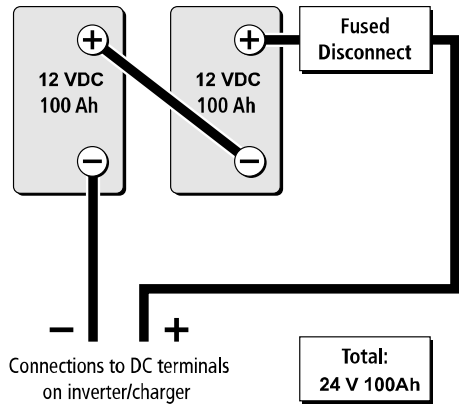

Figure 1-21 Batteries Connected in Series

Battery Series-Parallel Connections

As the name series-parallel implies, both the series and parallel configurations are used in combination. The result is an increase in both the voltage and the capacity of the total battery bank. The smaller, lower voltage batteries are first connected in series to obtain the necessary voltage, and then these “batteries connected-in-series” sets are connected in parallel to increase the battery bank capacity. See below.

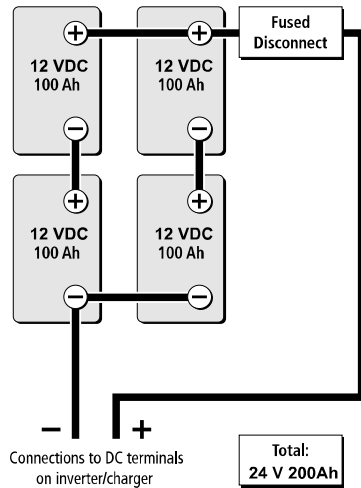

Figure 1-22 Batteries in Series-Parallel Connections

2

Specifications

NOTE: Specifications are subject to change without prior notice.

Inverter Specifications

NOTE: All inverter specifications are at nominal conditions: ambient temperature of 77 °F (25 °C), 24 VDC, unless otherwise specified.

AC Output	SW 2524 120/240	SW 4024 120/240
Output waveform	true sine wave	true sine wave
Continuous output power (AC) - Maximum - 30 minutes	2500 W 2700 W ^a	3400 W 4000 W ^b
Maximum continuous output current	11 A	15 A
Surge power rating (5 seconds)	5000 W ^c	7000 W ^d
Inverter peak output current	24.3 A	41 A
AC OUTPUT connection	Split-phase (L1/L2)	Split-phase (L1/L2)
Peak efficiency	91.5%	92%
Output power factor (capacitive or inductive)	0 to 1	0 to 1
Operating voltage range single-phase/split-phase	104/208 VAC to 127/254 VAC	104/208 VAC to 127/254 VAC
Nominal voltage single-phase/split-phase	120/240 VAC	120/240 VAC
Operating frequency range	selectable 50 or 60 Hz	selectable 50 or 60 Hz
Default output frequency	60 Hz	60 Hz
DC Input	SW 2524 120/240	SW 4024 120/240
Voltage range	20–34 VDC	20–34 VDC
Maximum continuous power voltage range	22–27 VDC	22–28 VDC
Maximum battery current	150 A	230 A
No-load power draw (Inverter On)	38 W	40 W
Low battery voltage shutdown cut-off (other values selectable)	21.0 V (default)	21.0 V (default)
High battery voltage shutdown cut-off (other values selectable)	33.0 V (default)	33.0 V (default)

a. 2700 W for 30 minutes, 0 W for 30 minutes.

b. 4000 W for 30 minutes, 0 W for 30 minutes.

c. 5000 W for 5 seconds, 2500 W for 300 seconds.

d. 7000 W for 5 seconds, 3500 W for 300 seconds.

Charger Specifications

NOTE: All charging specifications are at nominal conditions: ambient temperature of 77 °F (25 °C), split-phase 120/240 VAC, 60 Hz unless otherwise specified.

DC Output	SW 2524 120/240	SW 4024 120/240
Maximum output current	65 A	90 A
Nominal output voltage	24 VDC	24 VDC
Charging output voltage operation range	12.0–32.0 VDC	12.0–32.0 VDC
Equalization cycle	Automatic, Manual by SCP	Automatic, Manual by SCP
Optimal charging efficiency	90%	90%
Dead battery charge voltage	> 12.0 VDC	> 12.0 VDC
Charging methods (two settings)	Three-stage charge (Bulk, Absorption, Float) [default] Two-stage charge (Bulk, Absorption)	
Without a battery temperature sensor (three settings)	Cool 50 °F (10 °C) Warm 77 °F (25 °C) [default] Hot 104 °F (40 °C)	
With a battery temperature sensor (provided)	The temperature compensation coefficients on a 24-volt battery are as follows: Flooded: $54 \text{ mV} \times (25 \text{ °C} - \text{BTS } \text{°C})$ Gel: $54 \text{ mV} \times (25 \text{ °C} - \text{BTS } \text{°C})$ AGM: $42 \text{ mV} \times (25 \text{ °C} - \text{BTS } \text{°C})$	
AC Input	SW 2524 120/240	SW 4024 120/240
Power factor at full charge rate	> 0.98	> 0.98
Current	9 A	13 A
Voltage	120/240 VAC	120/240 VAC
Voltage range single-phase/split-phase	95/190 VAC to 135/270 VAC	95/190 VAC to 135/270 VAC
Frequency range	44 – 70Hz	44 – 70 Hz
AC INPUT Connection	Split-phase (L1/L2)	Split-phase (L1/L2)

AC Transfer Specifications

NOTE: All transfer specifications are at nominal conditions: ambient temperature of 77 °F (25 °C), split-phase 120/240 VAC, 60 Hz input, unless otherwise specified.

	SW 2524 120/240	SW 4024 120/240
Transfer time—utility to invert	< 20 ms	
Relay current rating	30 A ^a	
Minimum line-to-neutral AC input voltage for transfer	95 VAC RMS	
Maximum line-to-neutral AC input voltage for transfer	135 VAC RMS	
Minimum AC input frequency for transfer	44 Hz	
Maximum AC input frequency for transfer	70 Hz	
Cooling	Fan-cooled, temperature controlled	

a.Limited by SCP to 24 A due to CEC/NEC regulatory requirements.

Physical Specifications

	SW 2524 120/240	SW 4024 120/240
L × W × H	15.2×13.5×7.6 in (387×343×197 mm)	15.2×13.5×7.6 in (387×343×197 mm)
Net Weight	62 lbs. (28 kg)	76 lbs. (34.5 kg)

Environmental Specifications

	SW 2524 120/240	SW 4024 120/240
Nominal ambient temperature	77 °F (25 °C)	
Operating temperature range	-4 to 140 °F (-20 to 60 °C) starts derating above 77 °F (25 °C) (see following graph)	
Storage temperature range	-40 to 185 °F (-40 to 85 °C)	
Humidity: Operation/Storage	≤ 95% RH, non-condensing	
Ingress protection rating	Indoor only, IP 20	
Pollution degree	3	
Over voltage category (AC mains)	CAT III	
Altitude: Operating	6,562 ft. (2,000 m)	
Mounting	wall mount using installation bracket	

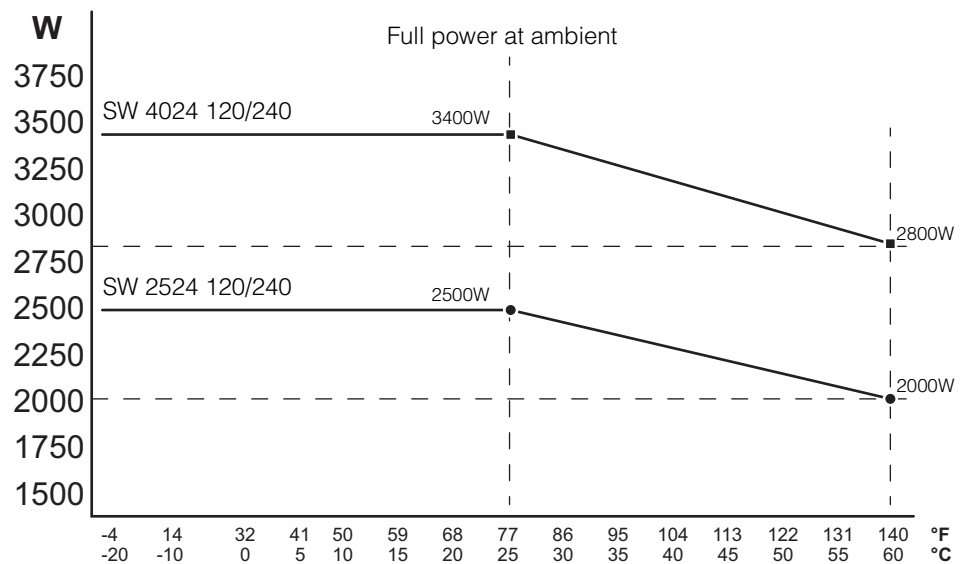

Figure 2-1 Output Power versus Temperature Derating Graph

Regulatory

	All Models
Safety	UL 1741 Ed. 2 CSA C22.2 NO. 107.1-01
EMC	FCC Part 15, Class B Industry Canada ICES-0003, Class B

3

Wiring Diagrams

“Wiring Diagrams” illustrate the most basic BOS configurations and are for reference only. Specific installations may require additional equipment to meet national or local electric codes. Ensure all safety requirements are strictly followed.

For.....	See....
“Single-Inverter System (Off-Grid/Power Backup)”	page 3-3
“Single-Inverter System Renewable Energy (Solar)”	page 3-5
“Dual-Inverter System Renewable Energy (Solar)”	page 3-7

Single-Inverter System (Off-Grid/Power Backup)

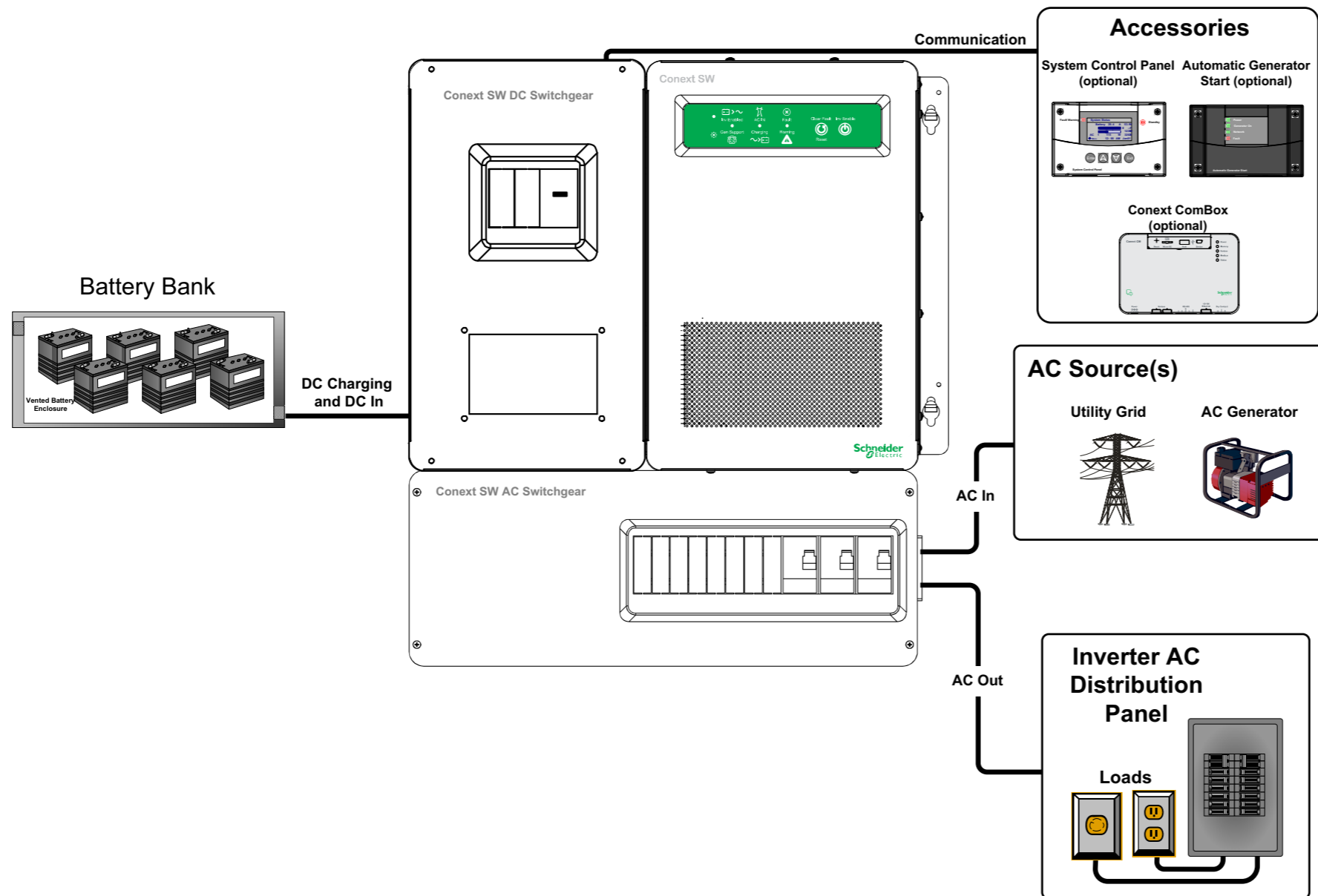

⚠ DANGER

ELECTRICAL SHOCK AND FIRE HAZARD

Installation must be done by qualified personnel to ensure compliance with all applicable installation codes and regulations. Instructions for installing the Connext SW are provided in this installation guide for use by qualified installers only.

Failure to follow these instructions will result in death or serious injury.

Figure 3-1 Single-Inverter System (Off-Grid/Backup) Overview

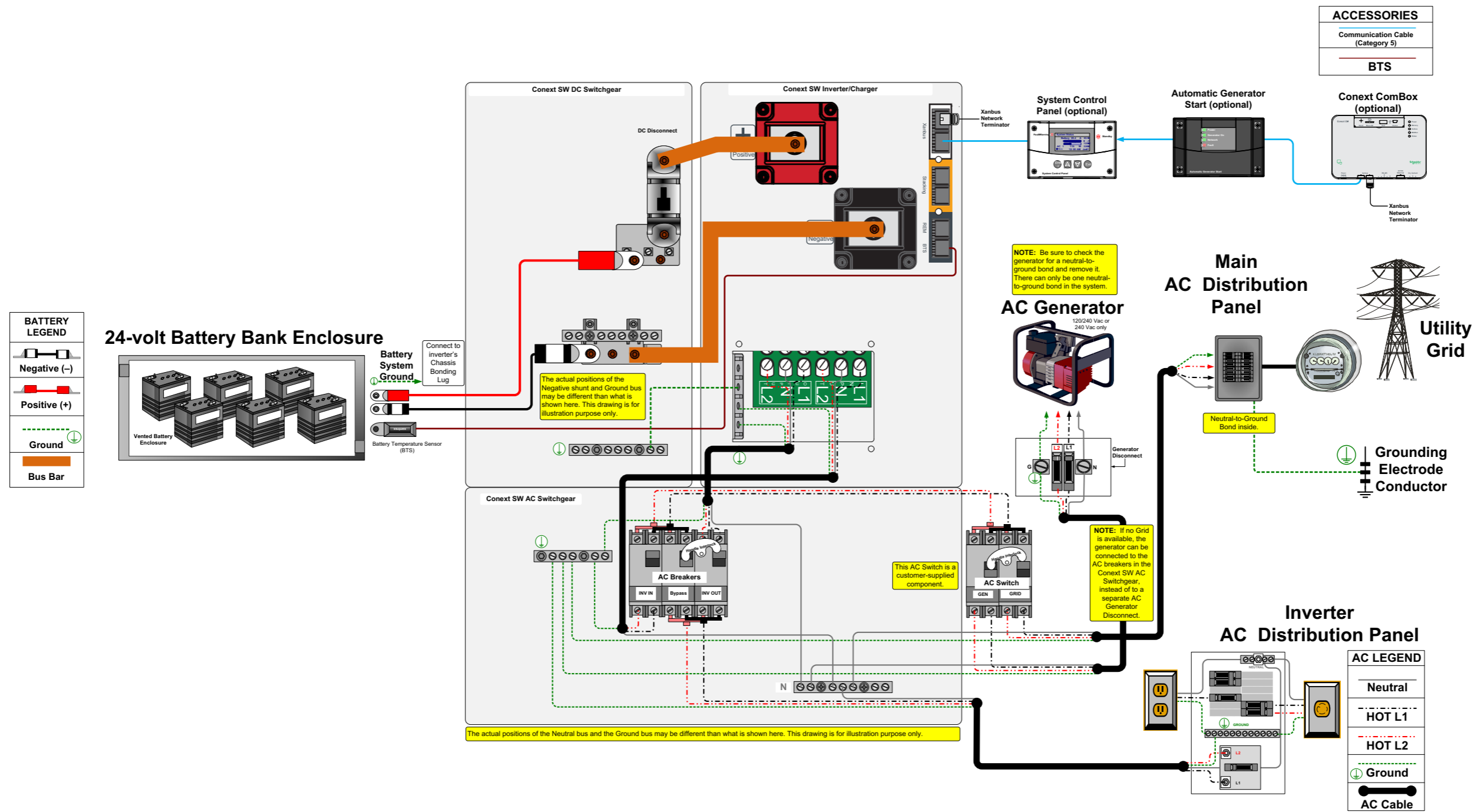
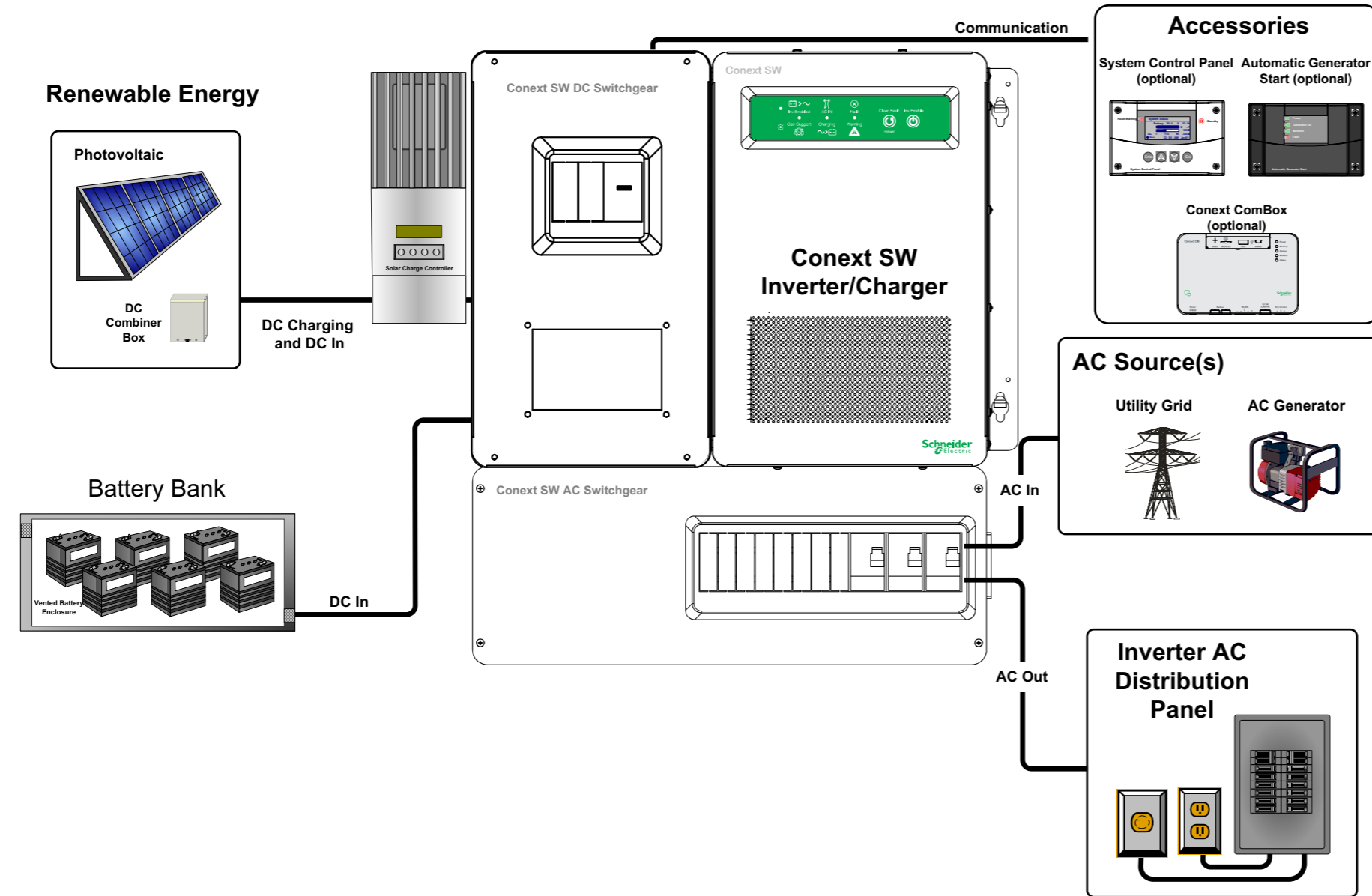

Figure 3-2 Single-Inverter System (Off-Grid/Backup) Wiring

Single-Inverter System Renewable Energy (Solar)



⚠ DANGER

ELECTRICAL SHOCK AND FIRE HAZARD

Installation must be done by qualified personnel to ensure compliance with all applicable installation codes and regulations. Instructions for installing the Conext SW are provided in this installation guide for use by qualified installers only.

Failure to follow these instructions will result in death or serious injury.

Figure 3-3 Single-Inverter System Renewable Energy (Solar) Overview

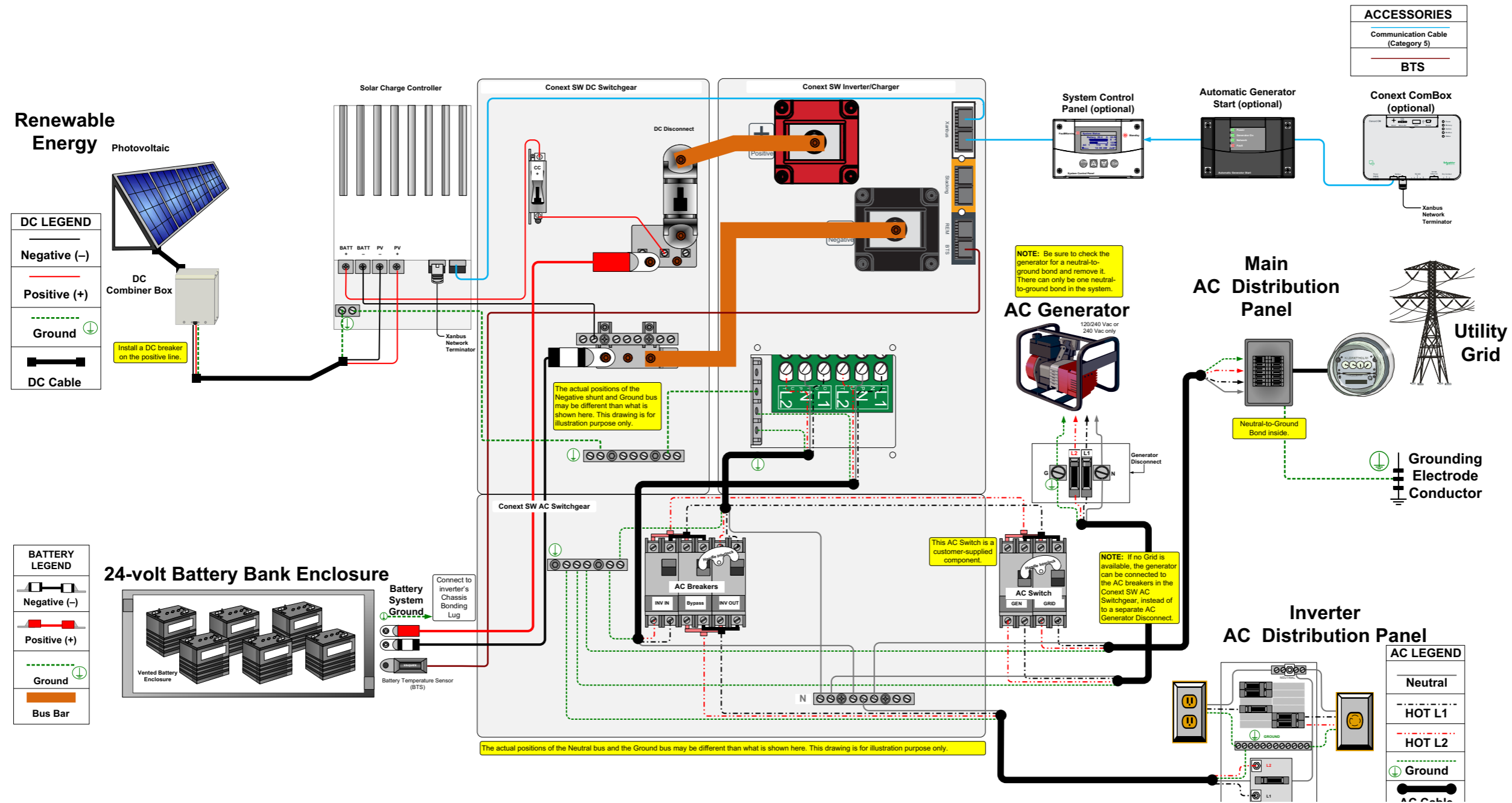
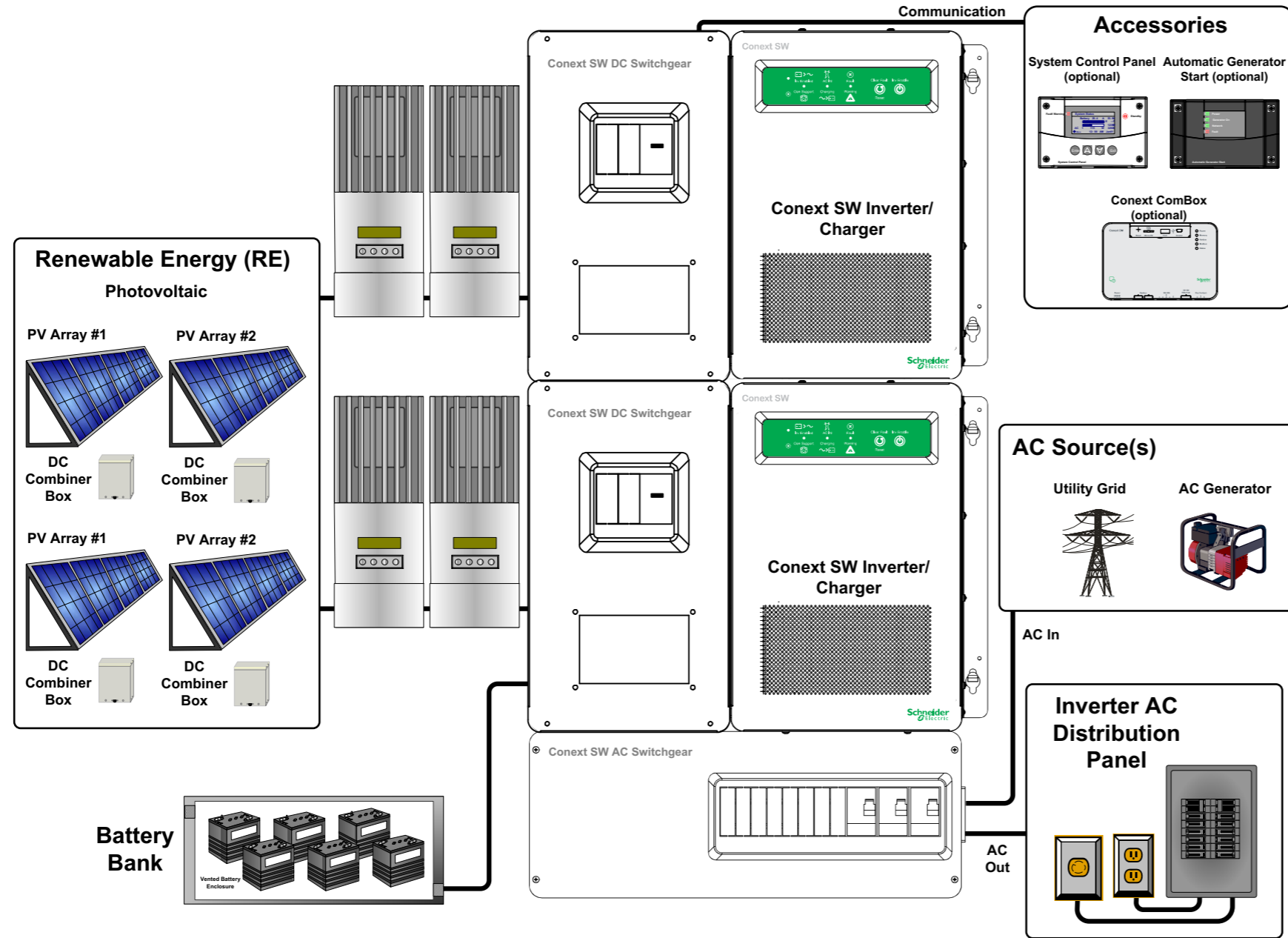

Figure 3-4 Dual-Inverter System Renewable Energy (Solar) Wiring

Dual-Inverter System Renewable Energy (Solar)



⚠ DANGER

ELECTRICAL SHOCK AND FIRE HAZARD

Installation must be done by qualified personnel to ensure compliance with all applicable installation codes and regulations. Instructions for installing the Connext SW are provided in this installation guide for use by qualified installers only.

Failure to follow these instructions will result in death or serious injury.

Figure 3-5 Dual-Inverter System Renewable Energy (Solar) Overview

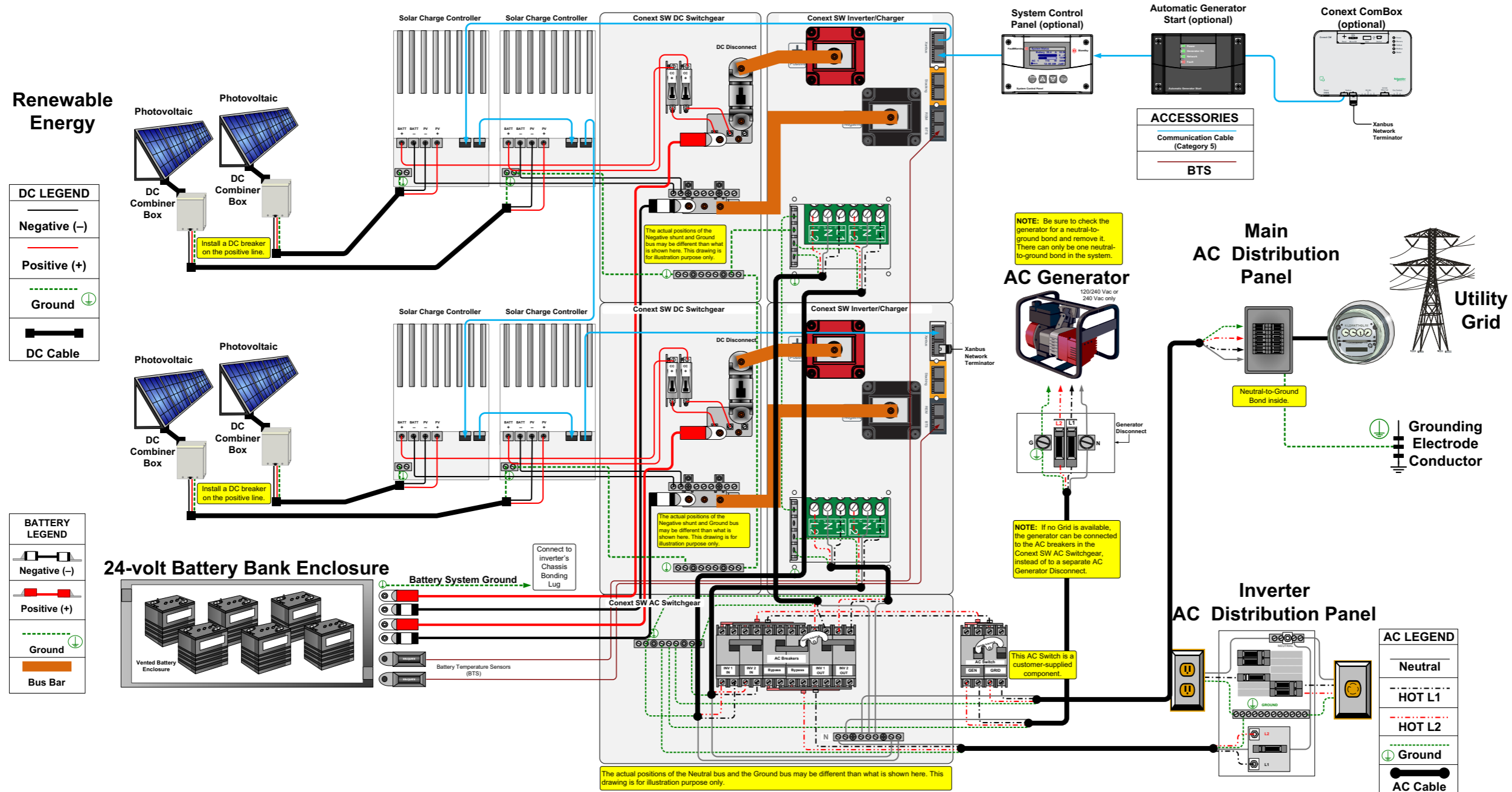

Figure 3-6 Dual-Inverter System Renewable Energy (Solar) Wiring

Schneider Electric

www.schneider-electric.com

For other country details please contact your local Schneider Electric Sales Representative or visit the Schneider Electric website at:

<http://www.schneider-electric.com/sites/corporate/en/support/operations/local-operations/local-operations.page>