

PART # TABLE	
P/N	DESCRIPTION
302045M	UNIVERSAL AF MID CLAMP - MILL
302045D	UNIVERSAL AF MID CLAMP - DRK
302050M	UNIVERSAL AF END CLAMP - MILL
302050D	UNIVERSAL AF END CLAMP - DRK

UNIVERSAL AF
END CLAMP

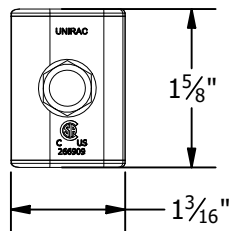

UNIVERSAL AF
MID CLAMP

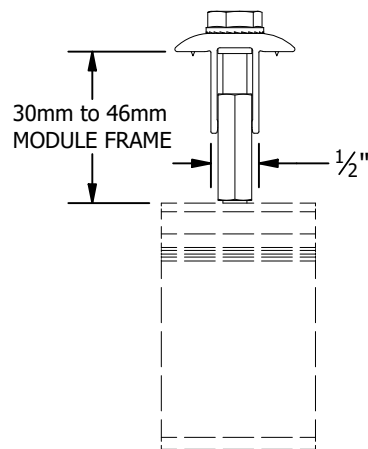
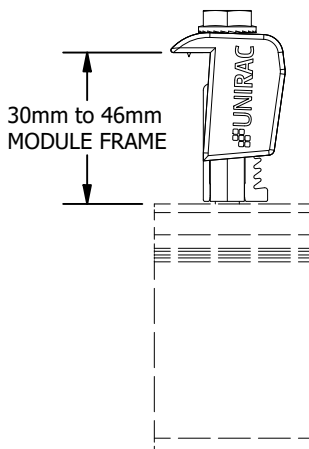
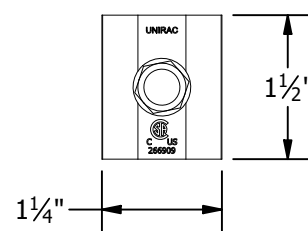

UNIVERSAL
MID CLAMP

UNIVERSAL
END CLAMP

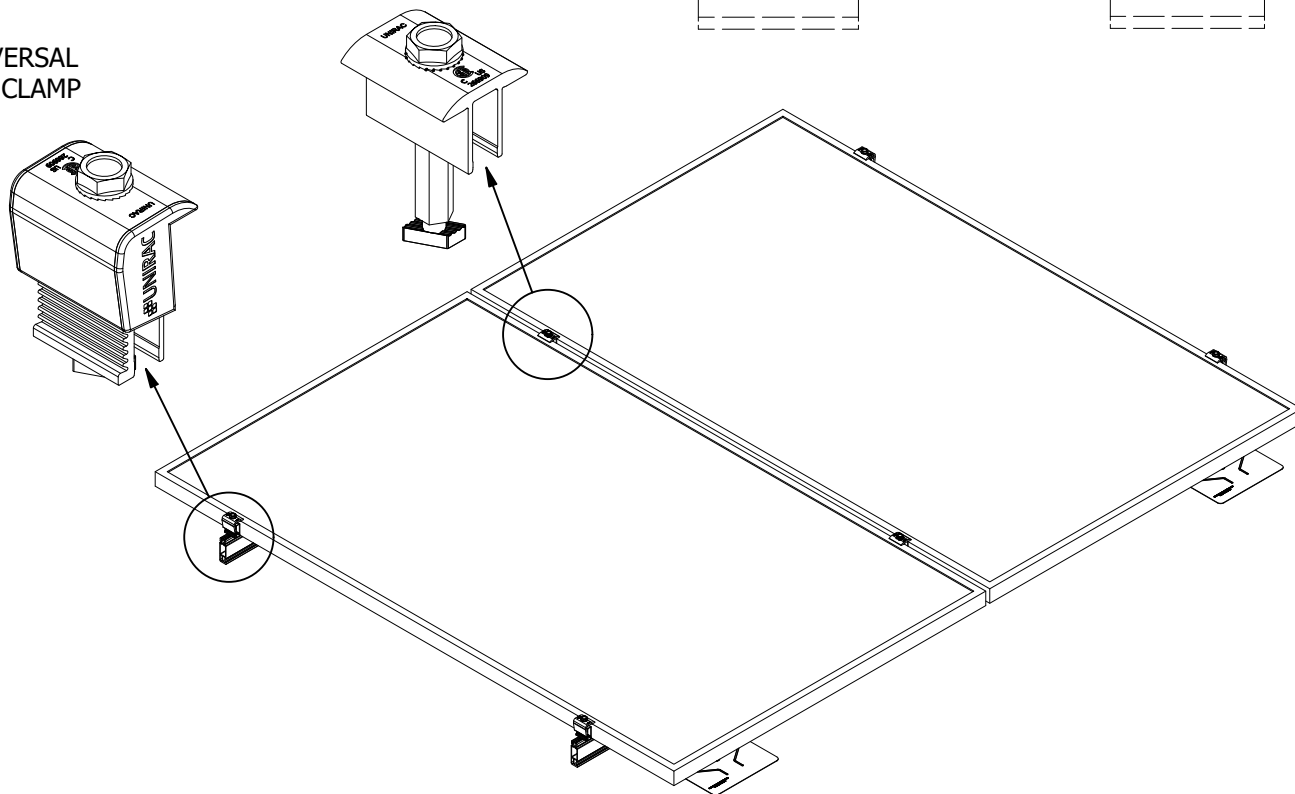

1411 BROADWAY BLVD. NE
ALBUQUERQUE, NM 87102 USA
PHONE: 505.242.6411
WWW.UNIRAC.COM

PRODUCT LINE:	SOLARMOUNT
DRAWING TYPE:	PART & ASSEMBLY
DESCRIPTION:	UNIVERSAL AF CLAMPS
REVISION DATE:	9/28/2020

DRAWING NOT TO SCALE
ALL DIMENSIONS ARE
NOMINAL

PRODUCT PROTECTED BY
ONE OR MORE US PATENTS

LEGAL NOTICE

SM-A01B

SHEET

PRO SERIES END CLAMP

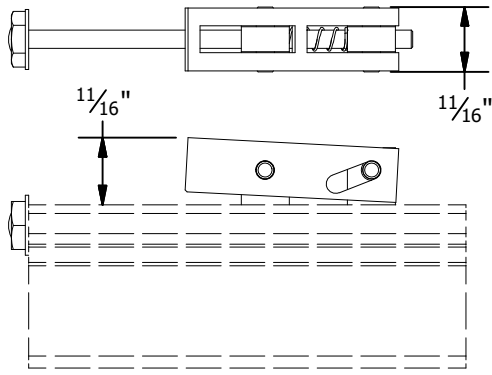

PRO SERIES MID CLAMP

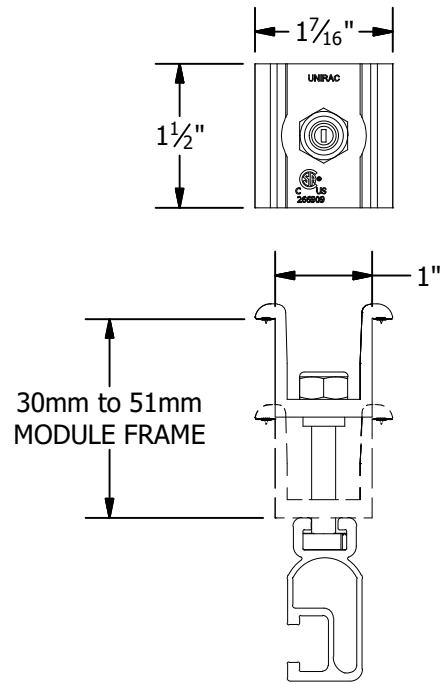

PART # TABLE	
P/N	DESCRIPTION
302035M	ENDCLAMP PRO
302030M	MIDCLAMP PRO - MILL
302030D	MIDCLAMP PRO - DRK

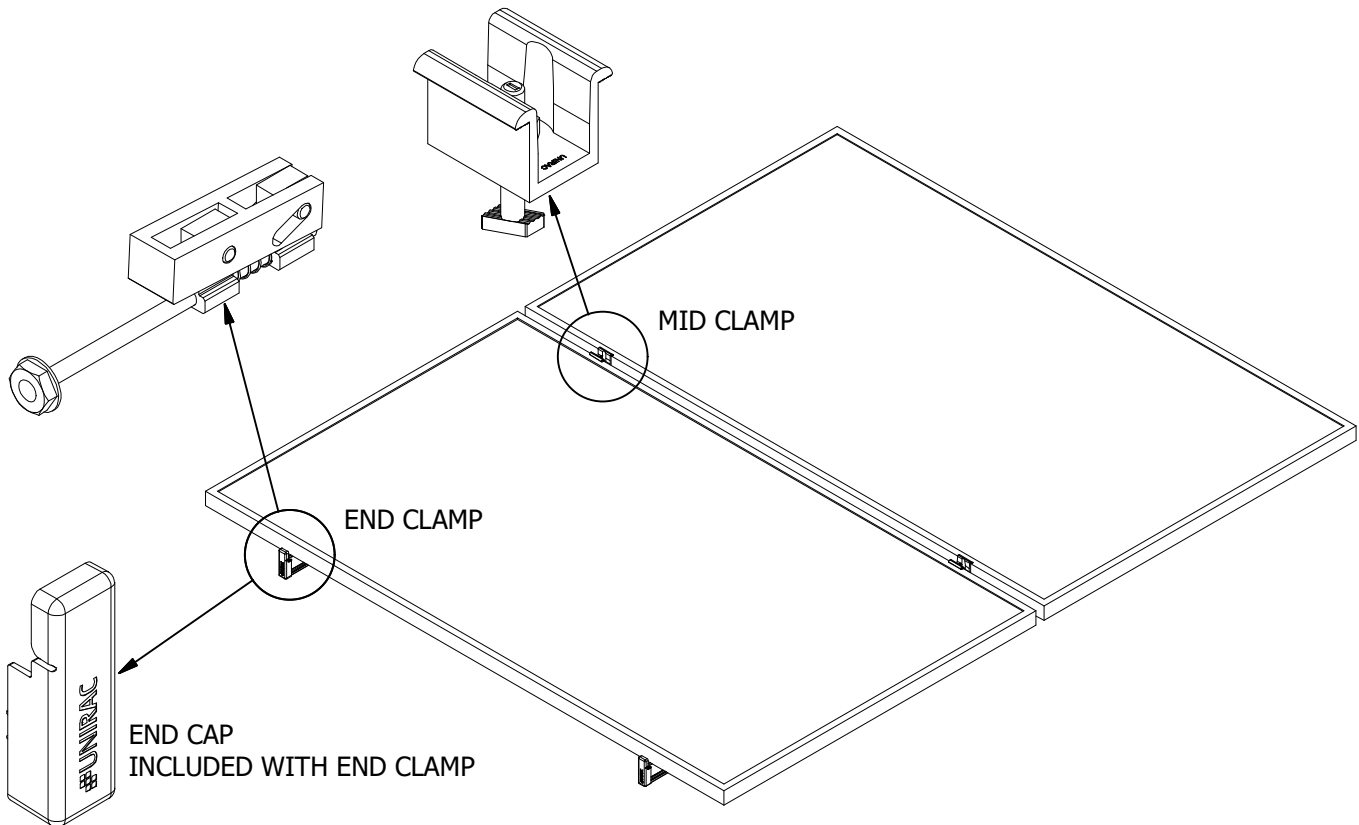

1411 BROADWAY BLVD. NE
 ALBUQUERQUE, NM 87102 USA
 PHONE: 505.242.6411
 WWW.UNIRAC.COM

PRODUCT LINE:	SOLARMOUNT
DRAWING TYPE:	PART & ASSEMBLY
DESCRIPTION:	PRO SERIES BONDING CLAMPS
REVISION DATE:	10/26/2017

DRAWING NOT TO SCALE
 ALL DIMENSIONS ARE NOMINAL

PRODUCT PROTECTED BY ONE OR MORE US PATENTS

LEGAL NOTICE

SM-A01

SHEET

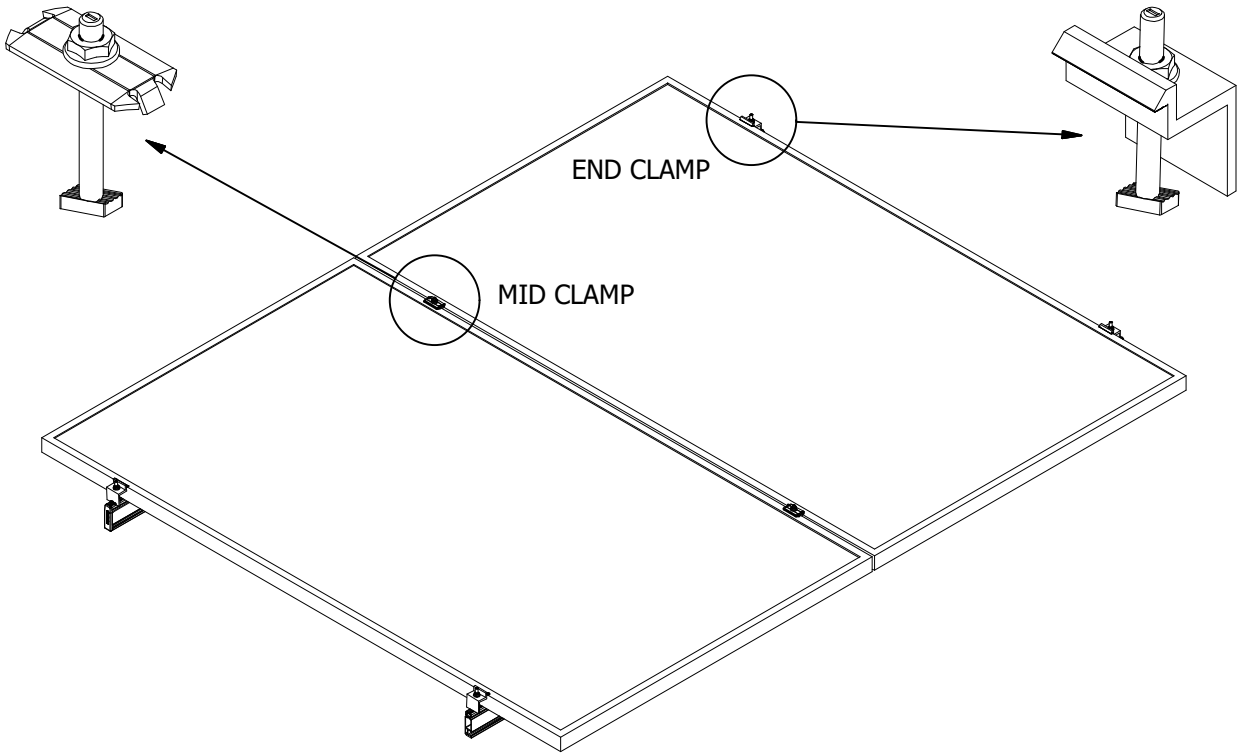

PART # TABLE	
P/N	DESCRIPTION
302027C	SM BND MIDCLAMP BC SS
302027D	SM BND MIDCLAMP BC DRK SS
302028C	SM BND MIDCLAMP EF SS
302028D	SM BND MIDCLAMP EF DRK SS
302029C	SM BND MIDCLAMP DK SS
302029D	SM BND MIDCLAMP DK DRK SS
	FOR BONDING END CLAMP REFER TO SHEET SM-P05

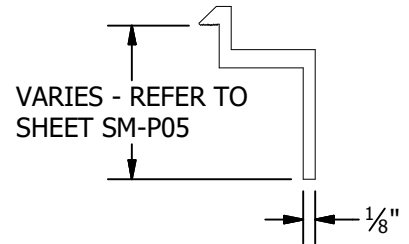
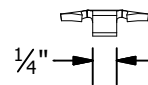
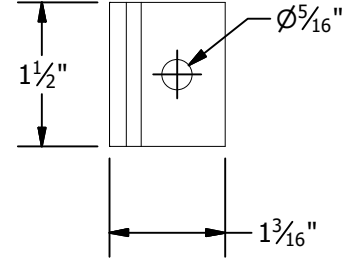
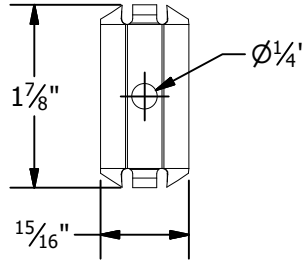

BONDING SM MID CLAMP

BONDING SM END CLAMP

UNIRAC
 1411 BROADWAY BLVD. NE
 ALBUQUERQUE, NM 87102 USA
 PHONE: 505.242.6411
 WWW.UNIRAC.COM

PRODUCT LINE:	SOLARMOUNT
DRAWING TYPE:	PART & ASSEMBLY
DESCRIPTION:	BONDING TOP CLAMPS
REVISION DATE:	10/26/2017

DRAWING NOT TO SCALE
 ALL DIMENSIONS ARE
 NOMINAL

PRODUCT PROTECTED BY
 ONE OR MORE US PATENTS

LEGAL NOTICE

SM-A01A

SHEET

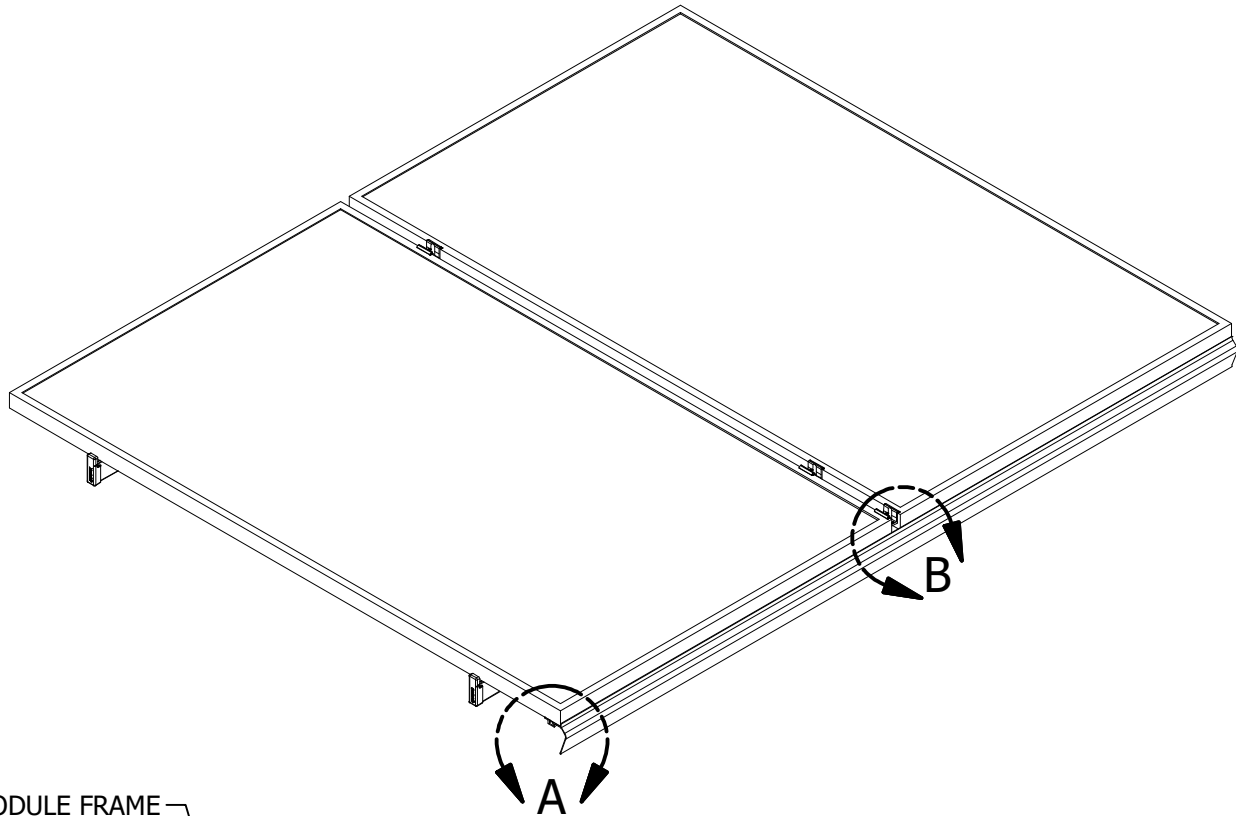

MODULE FRAME

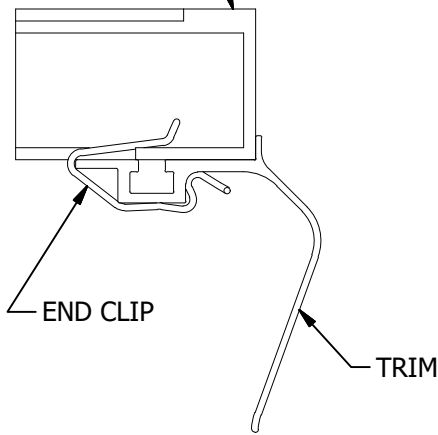

END CLIP

TRIM

DETAIL A
TRIM END CLIP

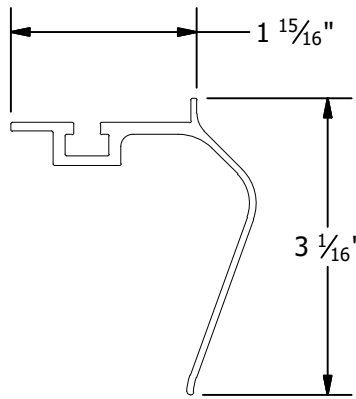

TRIM

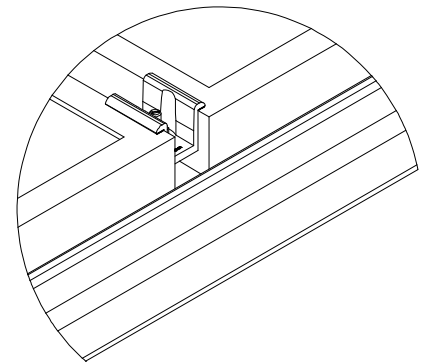

DETAIL B
MID CLAMP TRIM CONNECTION

PART # TABLE		
P/N	DESCRIPTION	LENGTH
206072D-B	SM TRIM DRK	168"
008025S	SM TRIM END CLIP	-



1411 BROADWAY BLVD. NE
ALBUQUERQUE, NM 87102 USA
PHONE: 505.242.6411
WWW.UNIRAC.COM

PRODUCT LINE:	SOLARMOUNT
DRAWING TYPE:	PART & ASSEMBLY
DESCRIPTION:	SM TRIM END CLIP
REVISION DATE:	9/27/2017

DRAWING NOT TO SCALE
ALL DIMENSIONS ARE
NOMINAL

PRODUCT PROTECTED BY
ONE OR MORE US PATENTS
LEGAL NOTICE

SM-A02

SHEET

NOTES:

1. INSTALLATION TO BE COMPLETED IN ACCORDANCE WITH MANUFACTURER'S WRITTEN SPECIFICATIONS AND INSTALLATION INSTRUCTIONS.
2. PACKAGING: KITS OF 10

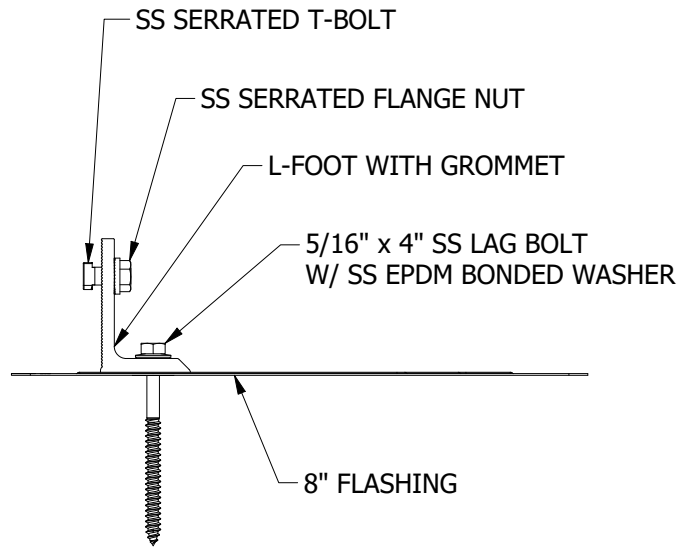
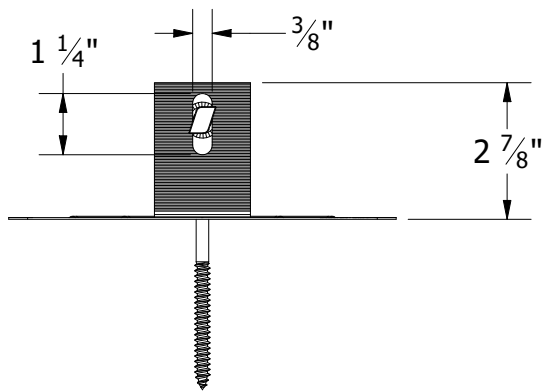
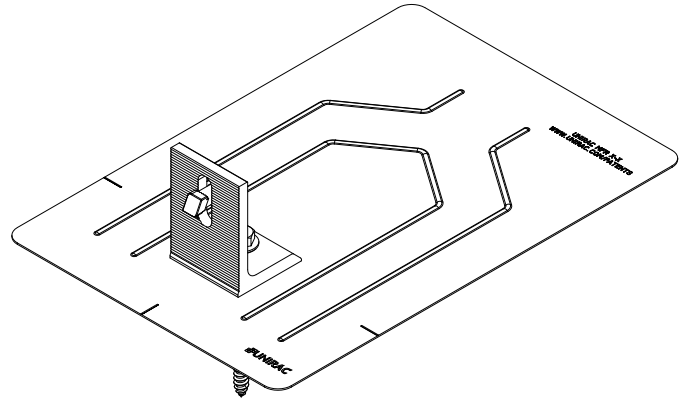
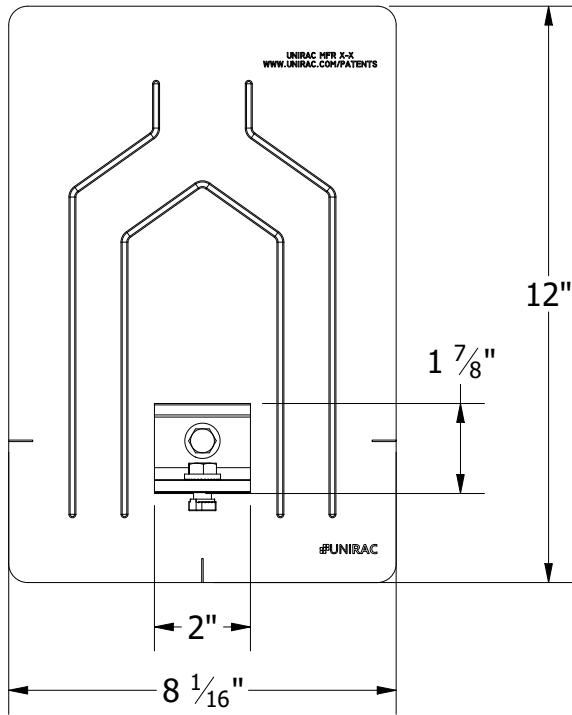

PART # TABLE	
P/N	DESCRIPTION
004055M	FLASHKIT PRO MILL
004055D	FLASHKIT PRO DRK



1411 BROADWAY BLVD. NE
 ALBUQUERQUE, NM 87102 USA
 PHONE: 505.242.6411
 WWW.UNIRAC.COM

PRODUCT LINE:	SOLARMOUNT
DRAWING TYPE:	KIT DETAIL
DESCRIPTION:	FLASHKIT PRO
REVISION DATE:	4/28/2020

DRAWING NOT TO SCALE
 ALL DIMENSIONS ARE
 NOMINAL

PRODUCT PROTECTED BY
 ONE OR MORE US PATENTS
 LEGAL NOTICE

SM-A03
 SHEET

NOTES:

1. INSTALLATION TO BE COMPLETED IN ACCORDANCE WITH MANUFACTURER'S WRITTEN SPECIFICATIONS AND INSTALLATION INSTRUCTIONS.
2. PACKAGING: KITS OF 10

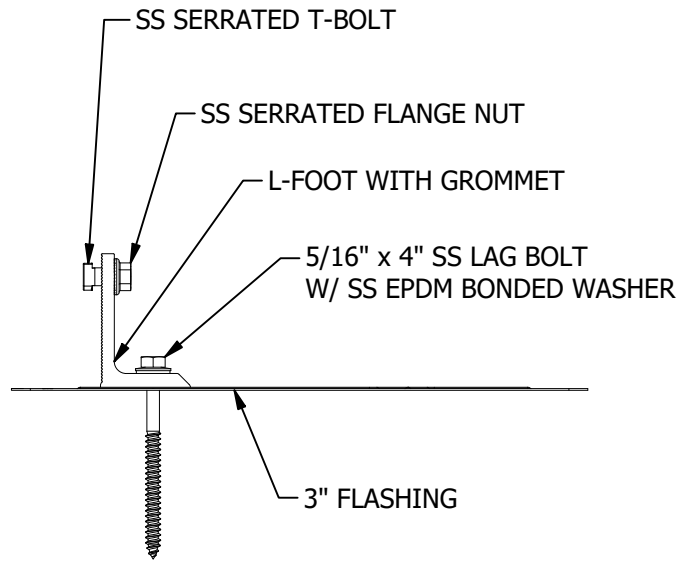
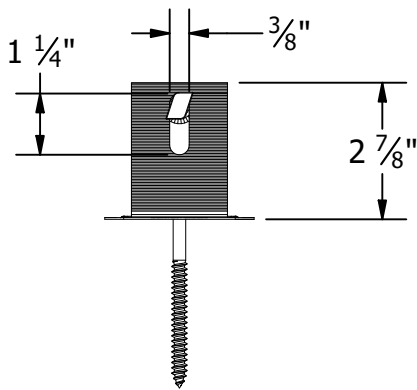
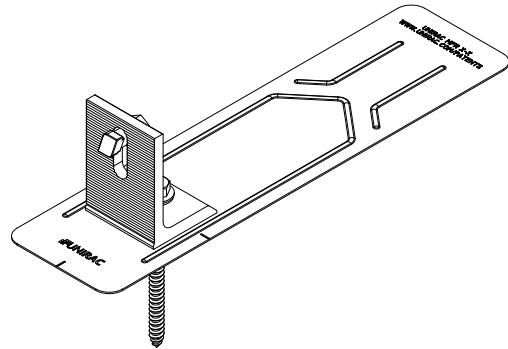
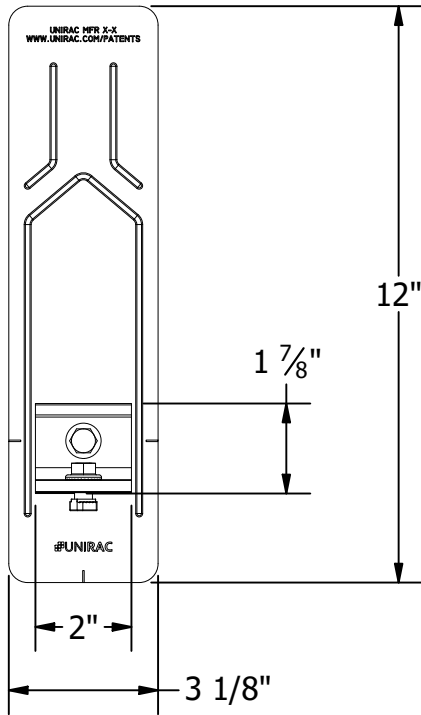

PART # TABLE	
P/N	DESCRIPTION
004015M	FLASHKIT PRO SB, MILL
004015D	FLASHKIT PRO SB, DRK



1411 BROADWAY BLVD. NE
 ALBUQUERQUE, NM 87102 USA
 PHONE: 505.242.6411
 WWW.UNIRAC.COM

PRODUCT LINE:	SOLARMOUNT
DRAWING TYPE:	KIT DETAIL
DESCRIPTION:	FLASHKIT PRO SB
REVISION DATE:	4/20/2021

DRAWING NOT TO SCALE
 ALL DIMENSIONS ARE
 NOMINAL

PRODUCT PROTECTED BY
 ONE OR MORE US PATENTS
 LEGAL NOTICE

SM-A16
 SHEET

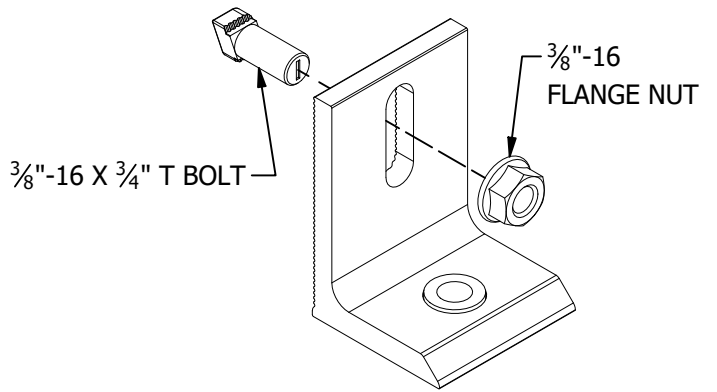
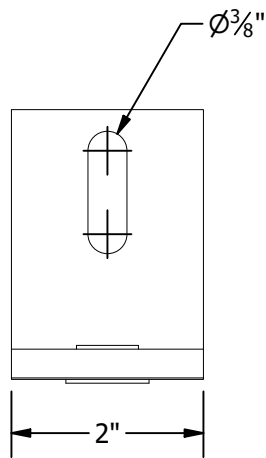
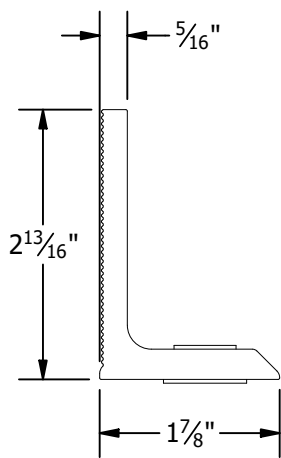

L-FOOT

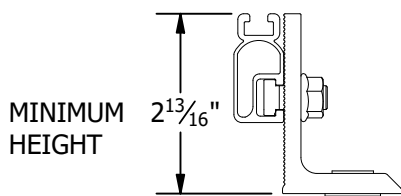

MINIMUM HEIGHT

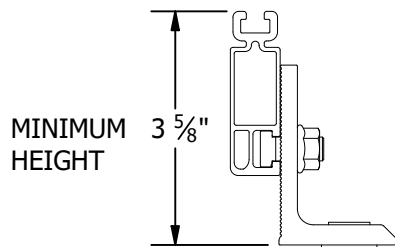

MINIMUM HEIGHT

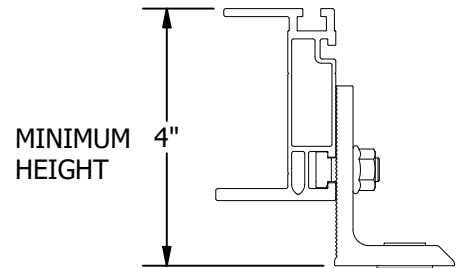

MINIMUM HEIGHT

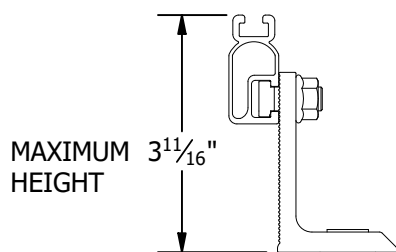

MAXIMUM HEIGHT

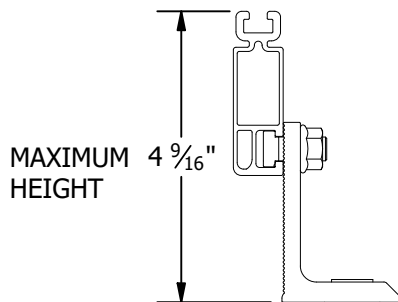

MAXIMUM HEIGHT

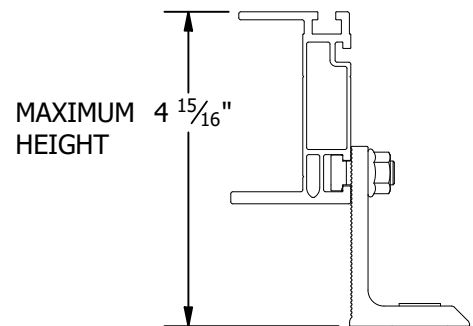

MAXIMUM HEIGHT

SOLARMOUNT LIGHT ON L-FOOT

SOLARMOUNT STANDARD ON L-FOOT

SOLARMOUNT HD ON L-FOOT



1411 BROADWAY BLVD. NE
ALBUQUERQUE, NM 87102 USA
PHONE: 505.242.6411
WWW.UNIRAC.COM

PRODUCT LINE:	SOLARMOUNT
DRAWING TYPE:	PART & ASSEMBLY
DESCRIPTION:	L-FOOT
REVISION DATE:	11/19/2018

DRAWING NOT TO SCALE
ALL DIMENSIONS ARE
NOMINAL

PRODUCT PROTECTED BY
ONE OR MORE US PATENTS
LEGAL NOTICE

SM-A11

SHEET

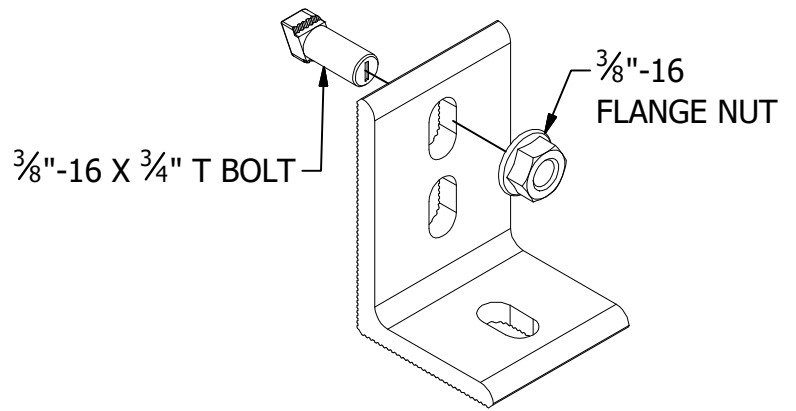
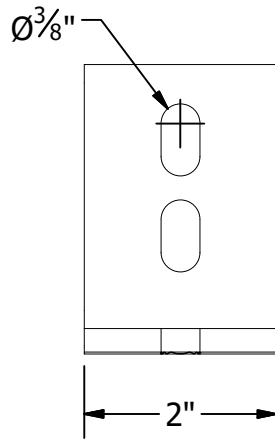
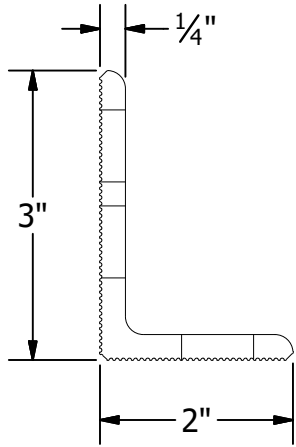

L-FOOT

PART # TABLE	
P/N	DESCRIPTION
304001C	L-FOOT SERR W/T-BOLT CLR
304001D	L-FOOT SERR W/T-BOLT DRK

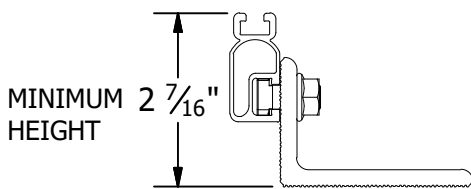

MINIMUM HEIGHT

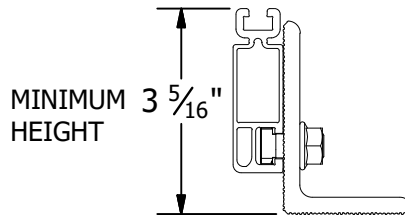

MINIMUM HEIGHT

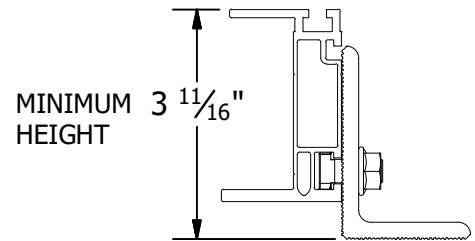

MINIMUM HEIGHT

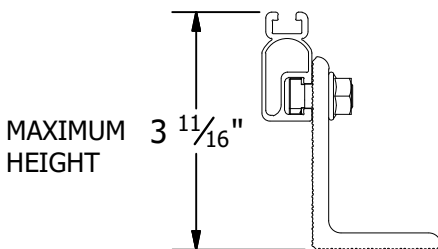

MAXIMUM HEIGHT

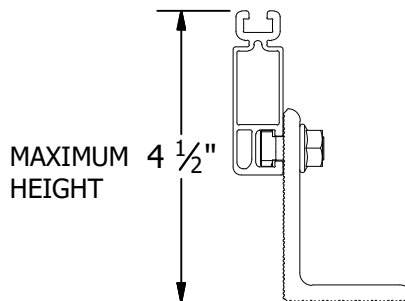

MAXIMUM HEIGHT

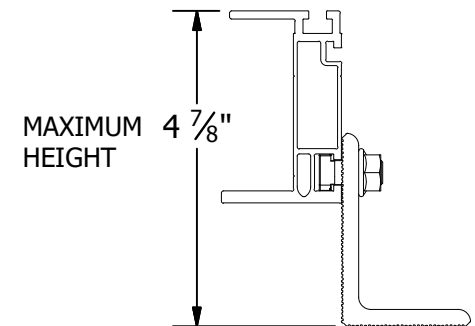

MAXIMUM HEIGHT

SOLARMOUNT LIGHT ON L-FOOT

SOLARMOUNT STANDARD ON L-FOOT

SOLARMOUNT HD ON L-FOOT

NOTES:

1. L-FOOT CAN BE INSTALLED IN TWO ORIENTATIONS, PLEASE REFER TO INSTRUCTIONS IN THE QUICK START GUIDE.



1411 BROADWAY BLVD. NE
ALBUQUERQUE, NM 87102 USA
PHONE: 505.242.6411
WWW.UNIRAC.COM

PRODUCT LINE:	SOLARMOUNT
DRAWING TYPE:	PART & ASSEMBLY
DESCRIPTION:	L-FOOT
REVISION DATE:	9/27/2017

DRAWING NOT TO SCALE
ALL DIMENSIONS ARE
NOMINAL

PRODUCT PROTECTED BY
ONE OR MORE US PATENTS
LEGAL NOTICE

SM-A04

SHEET

BONDING SPLICE BAR

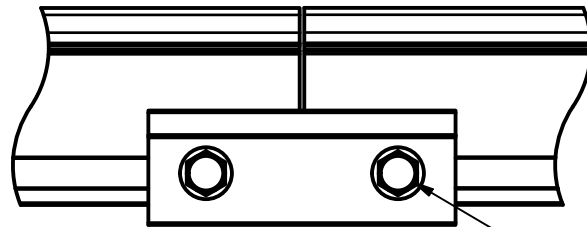
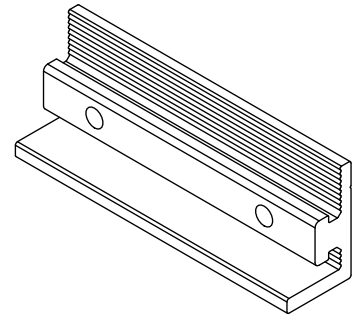
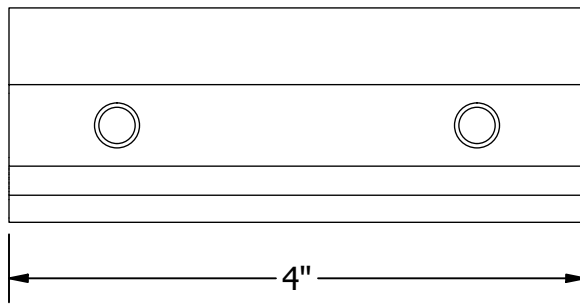
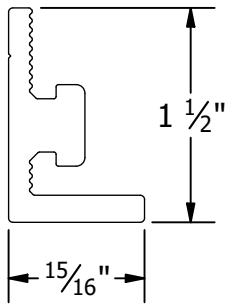

5/16"-18 TYPE F THREAD
CUTTING SCREWS INCLUDED

TYPICAL SPLICE BAR DETAIL

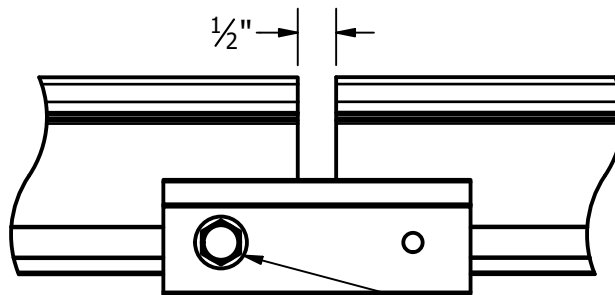

NOTE THAT ONLY 1 SCREW IS
USED AT AN EXPANSION JOINT.
THE SPLICE BAR DOES NOT BOND
ACROSS AN EXPANSION JOINT.
SEE INSTALLATION GUIDE FOR
INSTRUCTION.

TYPICAL EXPANSION JOINT DETAIL

PART # TABLE	
P/N	DESCRIPTION
303019M	BND SPLICE BAR PRO SERIES MILL
303019D	BND SPLICE BAR PRO SERIES DRK



1411 BROADWAY BLVD. NE
ALBUQUERQUE, NM 87102 USA
PHONE: 505.242.6411
WWW.UNIRAC.COM

PRODUCT LINE:	SOLARMOUNT
DRAWING TYPE:	PART & ASSEMBLY
DESCRIPTION:	BONDING SPLICE BAR PRO SERIES
REVISION DATE:	9/17/2019

DRAWING NOT TO SCALE ALL DIMENSIONS ARE NOMINAL
PRODUCT PROTECTED BY ONE OR MORE US PATENTS <hr/> LEGAL NOTICE

SM-A05
SHEET

NOTES:

1. SEE SM T1H INSTALLATION GUIDE FOR ASSEMBLY INSTRUCTIONS.

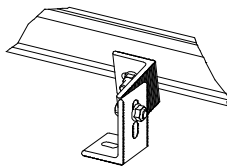
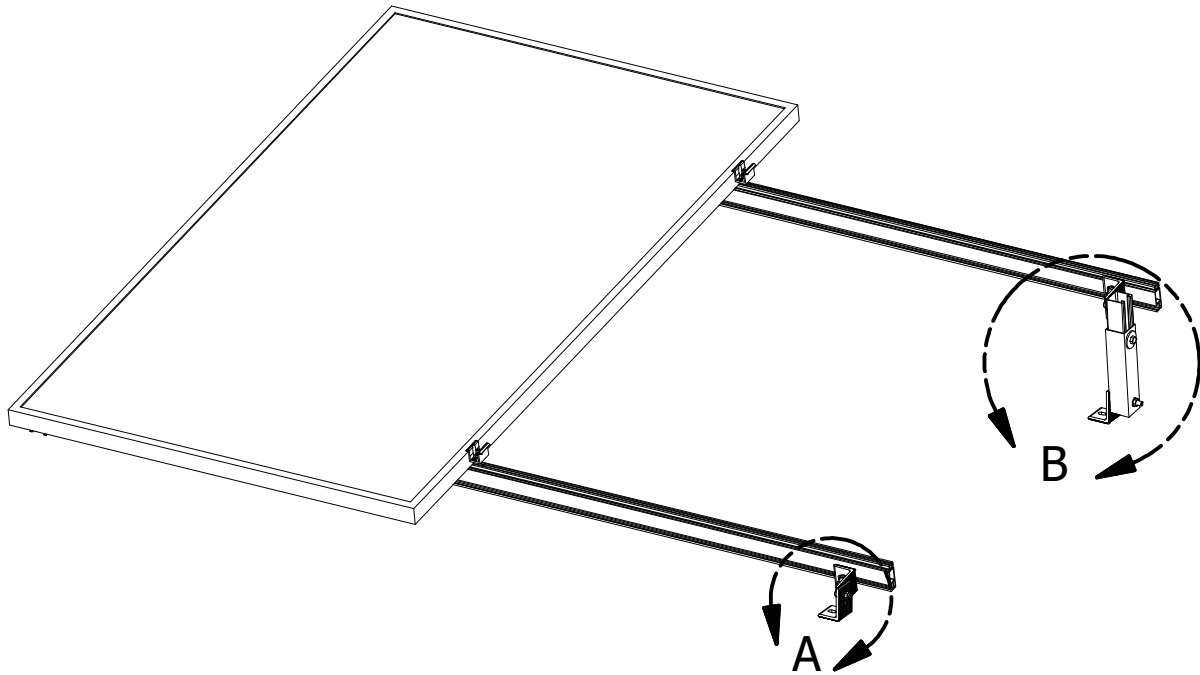

DETAIL A
FRONT L-FOOT HINGE

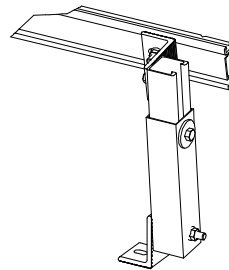

DETAIL B
REAR TILT LEG



1411 BROADWAY BLVD. NE
ALBUQUERQUE, NM 87102 USA
PHONE: 505.242.6411
WWW.UNIRAC.COM

PRODUCT LINE:	SOLARMOUNT TILT
DRAWING TYPE:	ASSEMBLY
DESCRIPTION:	LOW PROFILE TILT
REVISION DATE:	9/27/2017

DRAWING NOT TO SCALE
ALL DIMENSIONS ARE
NOMINAL

PRODUCT PROTECTED BY
ONE OR MORE US PATENTS
LEGAL NOTICE

SM-A07

SHEET

NOTES:

1. SEE SM T1H INSTALLATION GUIDE FOR ASSEMBLY INSTRUCTIONS.

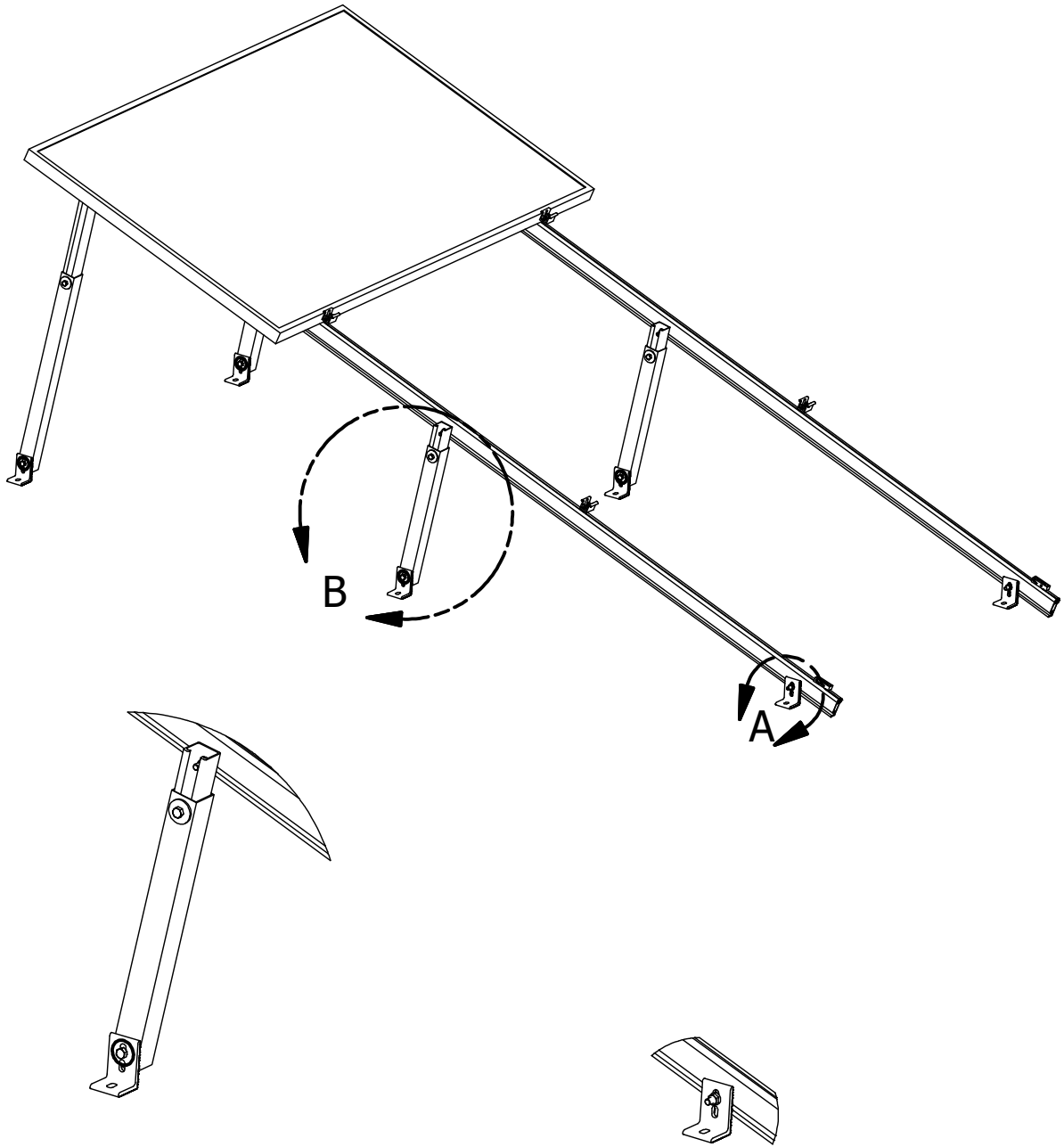

DETAIL B
REAR TILT LEG

DETAIL A
L FOOT



1411 BROADWAY BLVD. NE
ALBUQUERQUE, NM 87102 USA
PHONE: 505.242.6411
WWW.UNIRAC.COM

PRODUCT LINE:	SOLARMOUNT TILT
DRAWING TYPE:	ASSEMBLY
DESCRIPTION:	HIGH PROFILE TILT
REVISION DATE:	9/27/2017

DRAWING NOT TO SCALE
ALL DIMENSIONS ARE
NOMINAL

PRODUCT PROTECTED BY
ONE OR MORE US PATENTS
LEGAL NOTICE

SM-A08

SHEET

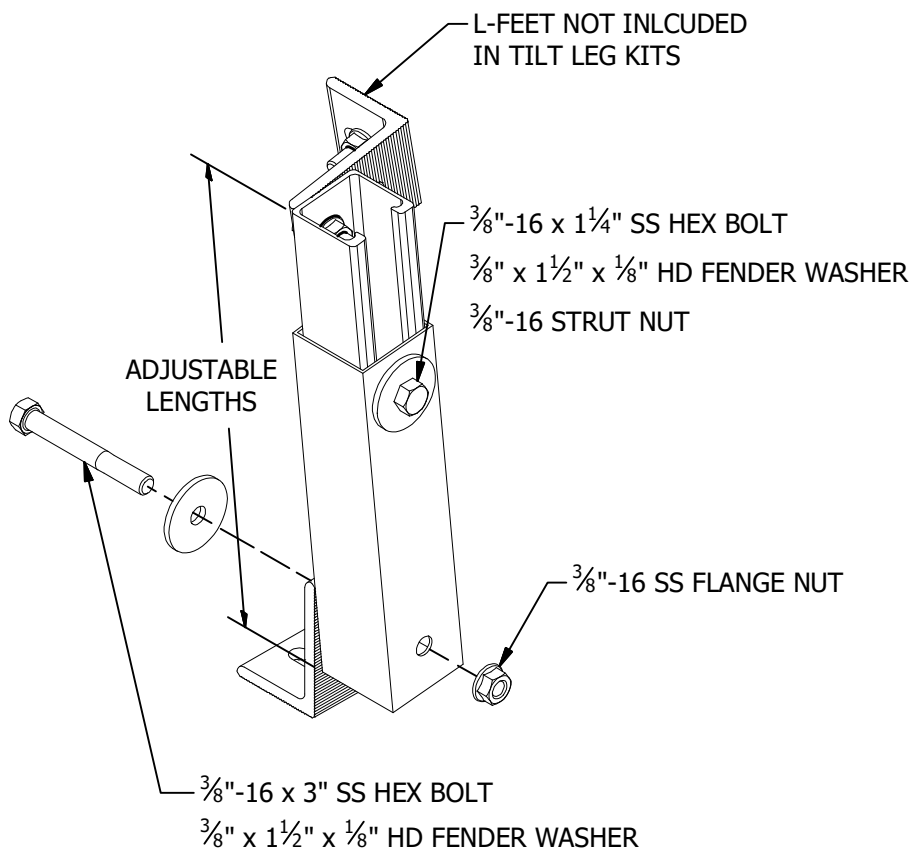
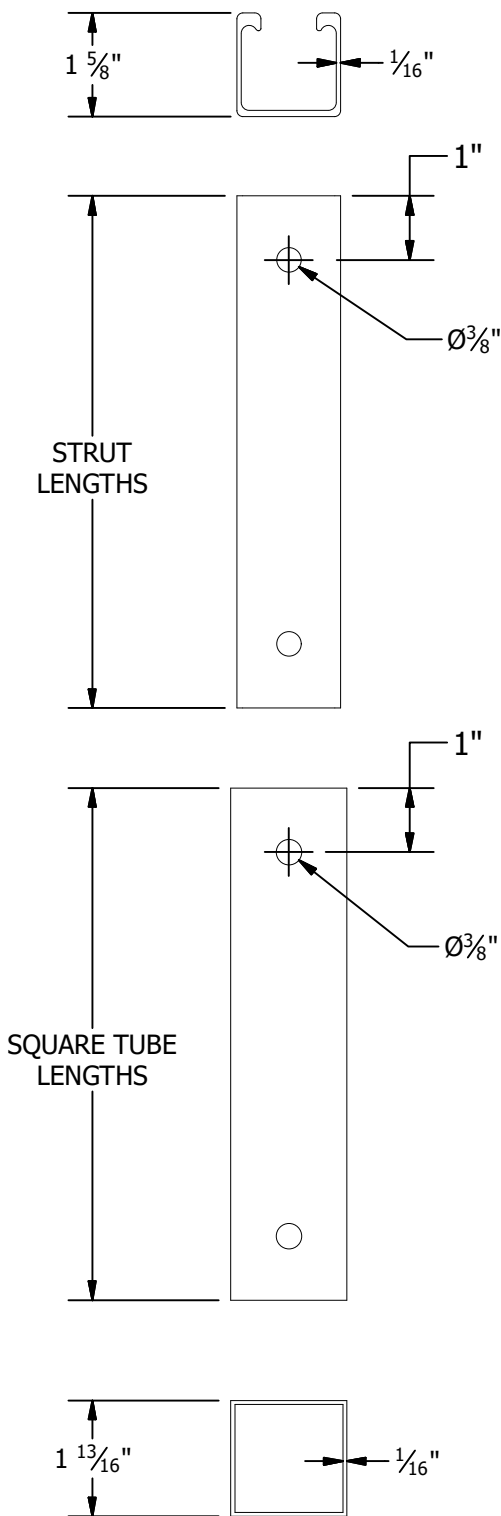

TILT LEG TABLE				
P/N	DESCRIPTION	TOTAL ADJUSTABLE LENGTHS	SQUARE TUBE	STRUT
307107M	SM ADJ TILT LEG, 8"-12", W/HDW	8" to 12"	8"	8"
307115M	SM ADJ TILT LEG, 18"-30", W/HDW	18" to 30"	18"	18"
307120M	SM ADJ TILT LEG, 26"-44", W/HDW	26" to 44"	26"	26"
307134M	SM ADJ TILT LEG, 40"-72", W/HDW	40" to 72"	40"	40"



1411 BROADWAY BLVD. NE
ALBUQUERQUE, NM 87102 USA
PHONE: 505.242.6411
WWW.UNIRAC.COM

PRODUCT LINE:	SOLARMOUNT TILT
DRAWING TYPE:	ASSEMBLY
DESCRIPTION:	ADJUSTABLE TILT LEG
REVISION DATE:	9/27/2017

DRAWING NOT TO SCALE
ALL DIMENSIONS ARE
NOMINAL

PRODUCT PROTECTED BY
ONE OR MORE US PATENTS
LEGAL NOTICE

SM-A09

SHEET

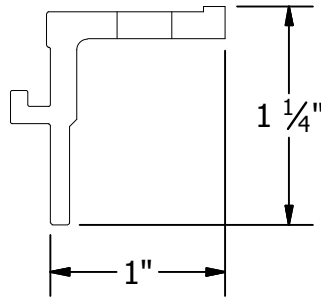
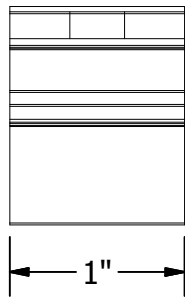

1/4"-20 X 3/4" SS HEX HEAD BOLT

1/4" FLAT WASHER

1/4"-20 SS FLANGE NUT

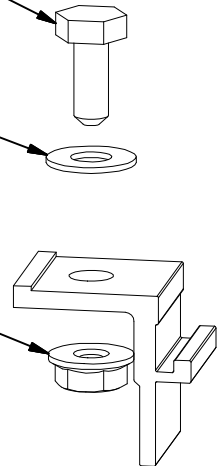

BOTTOM CLIP

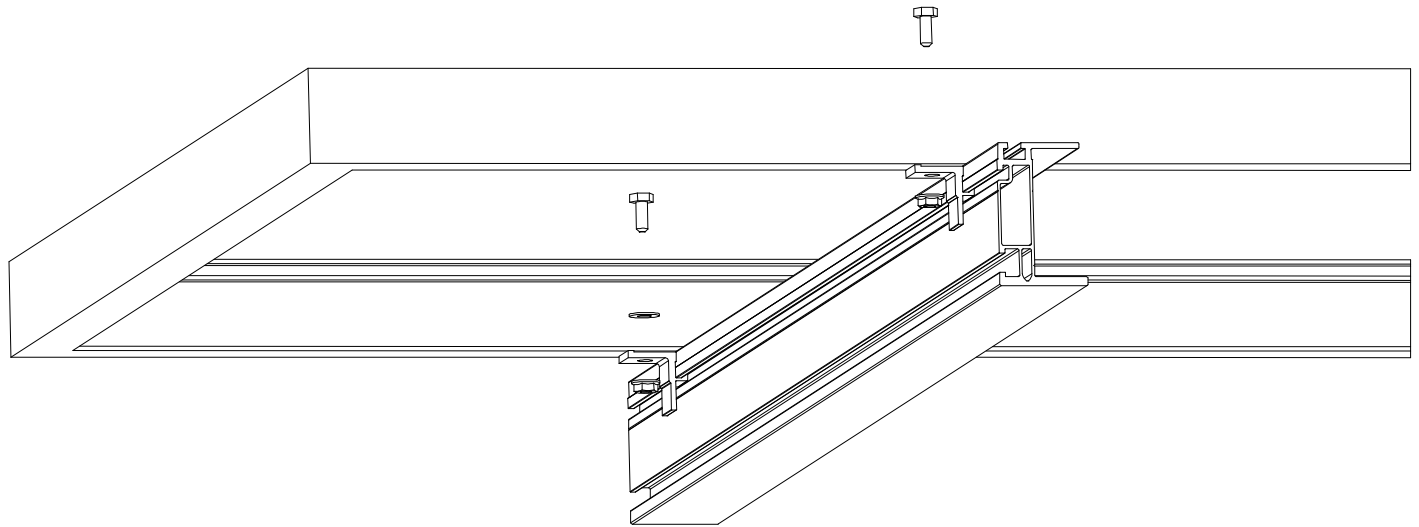

DETAIL A

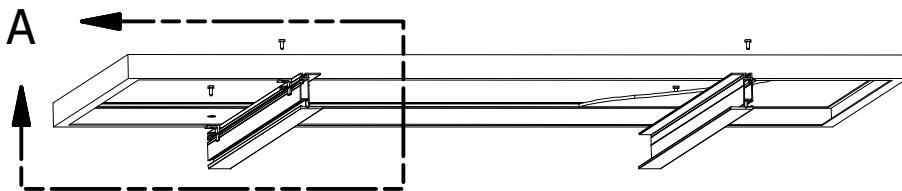

PART # TABLE

P/N	DESCRIPTION
302000C	SMHD BOTTOM CLIPS W/HDW CLR



1411 BROADWAY BLVD. NE
ALBUQUERQUE, NM 87102 USA
PHONE: 505.242.6411
WWW.UNIRAC.COM

PRODUCT LINE:	SOLARMOUNT HD
DRAWING TYPE:	PART & ASSEMBLY
DESCRIPTION:	BOTTOM CLIP
REVISION DATE:	9/27/2017

DRAWING NOT TO SCALE
ALL DIMENSIONS ARE
NOMINAL

PRODUCT PROTECTED BY
ONE OR MORE US PATENTS
LEGAL NOTICE

SM-A10

SHEET

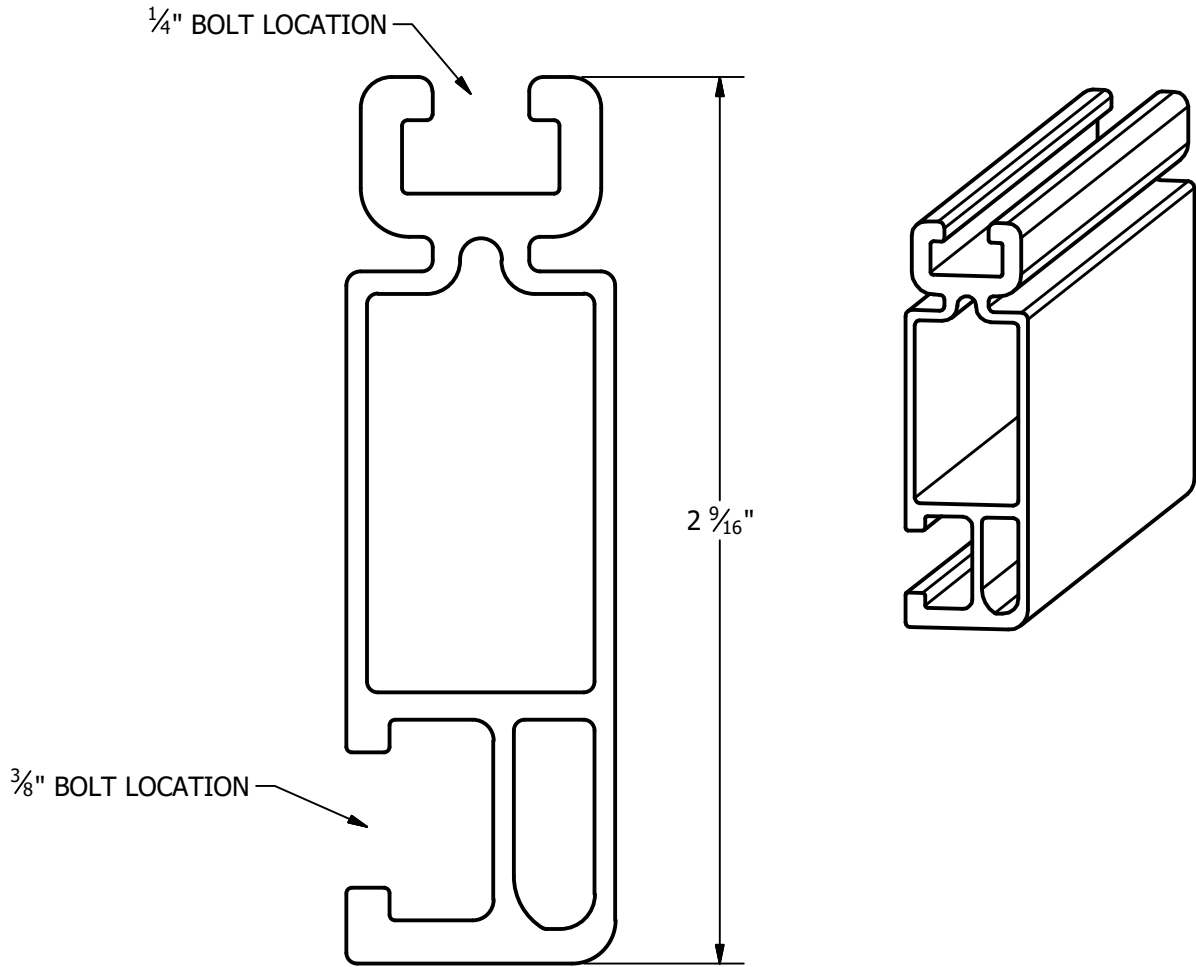

PART # TABLE		
P/N	DESCRIPTION	LENGTH
320132M	SM RAIL 132" MILL	132"
310132C	SM RAIL 132" CLR	132"
320168M	SM RAIL 168" MILL	168"
310168C	SM RAIL 168" CLR	168"
320168D	SM RAIL 168" DRK	168"
320208M	SM RAIL 208" MILL	208"
310208C	SM RAIL 208" CLR	208"
320240M	SM RAIL 240" MILL	240"
310240C	SM RAIL 240" CLR	240"
310240D	SM RAIL 240" DRK	240"



 1411 BROADWAY BLVD. NE
 ALBUQUERQUE, NM 87102 USA
 PHONE: 505.242.6411
 WWW.UNIRAC.COM

PRODUCT LINE:	SOLARMOUNT
DRAWING TYPE:	PART DETAIL
DESCRIPTION:	STANDARD RAIL
REVISION DATE:	9/11/2017

DRAWING NOT TO SCALE
ALL DIMENSIONS ARE
NOMINAL

PRODUCT PROTECTED BY
ONE OR MORE US PATENTS
LEGAL NOTICE

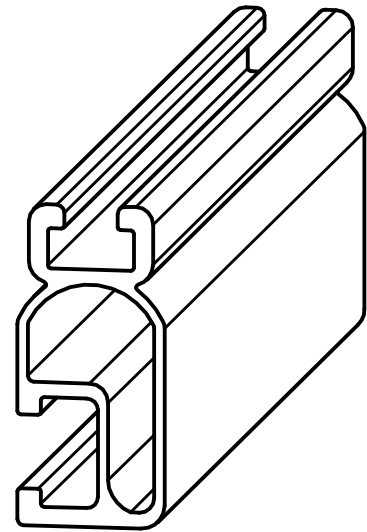
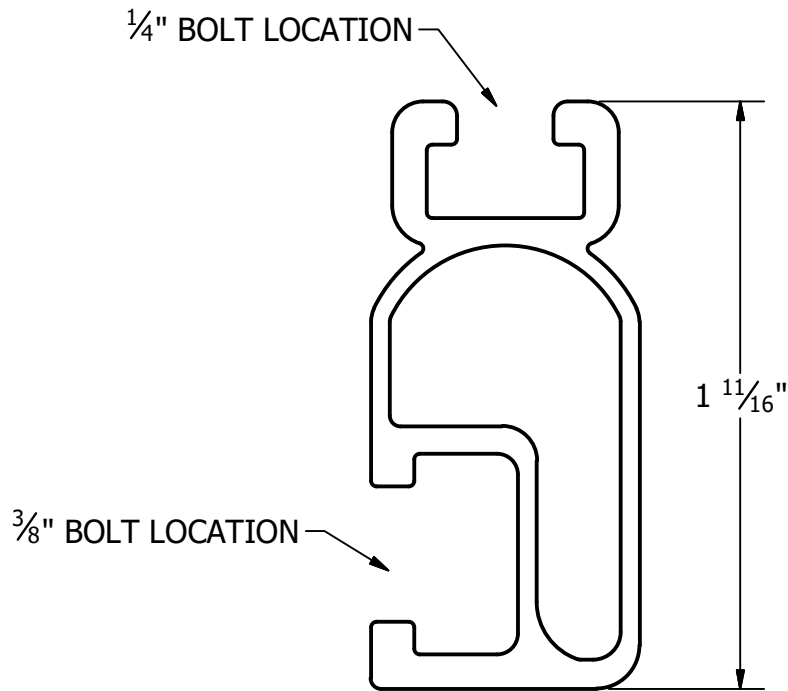
SM-P01
 SHEET



PART # TABLE		
P/N	DESCRIPTION	LENGTH
315168M	SM LIGHT RAIL 168" MILL	168"
315168D	SM LIGHT RAIL 168" DRK	168"
315240M	SM LIGHT RAIL 240" MILL	240"
315240D	SM LIGHT RAIL 240" DRK	240"



1411 BROADWAY BLVD. NE
 ALBUQUERQUE, NM 87102 USA
 PHONE: 505.242.6411
 WWW.UNIRAC.COM

PRODUCT LINE: SOLARMOUNT

DRAWING TYPE: PART DETAIL

DESCRIPTION: LIGHT RAIL

REVISION DATE: 9/11/2017

DRAWING NOT TO SCALE
 ALL DIMENSIONS ARE
 NOMINAL

PRODUCT PROTECTED BY
 ONE OR MORE US PATENTS

LEGAL NOTICE

SM-P02

SHEET

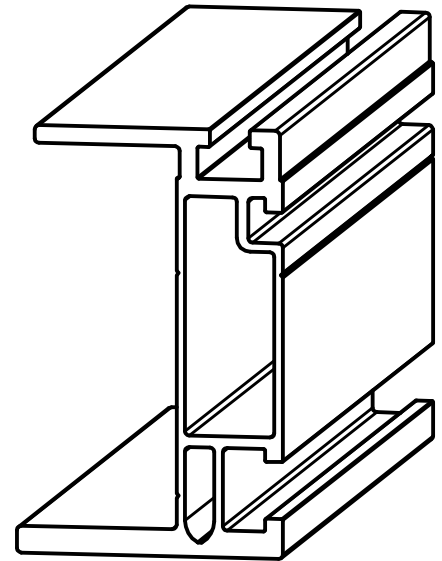
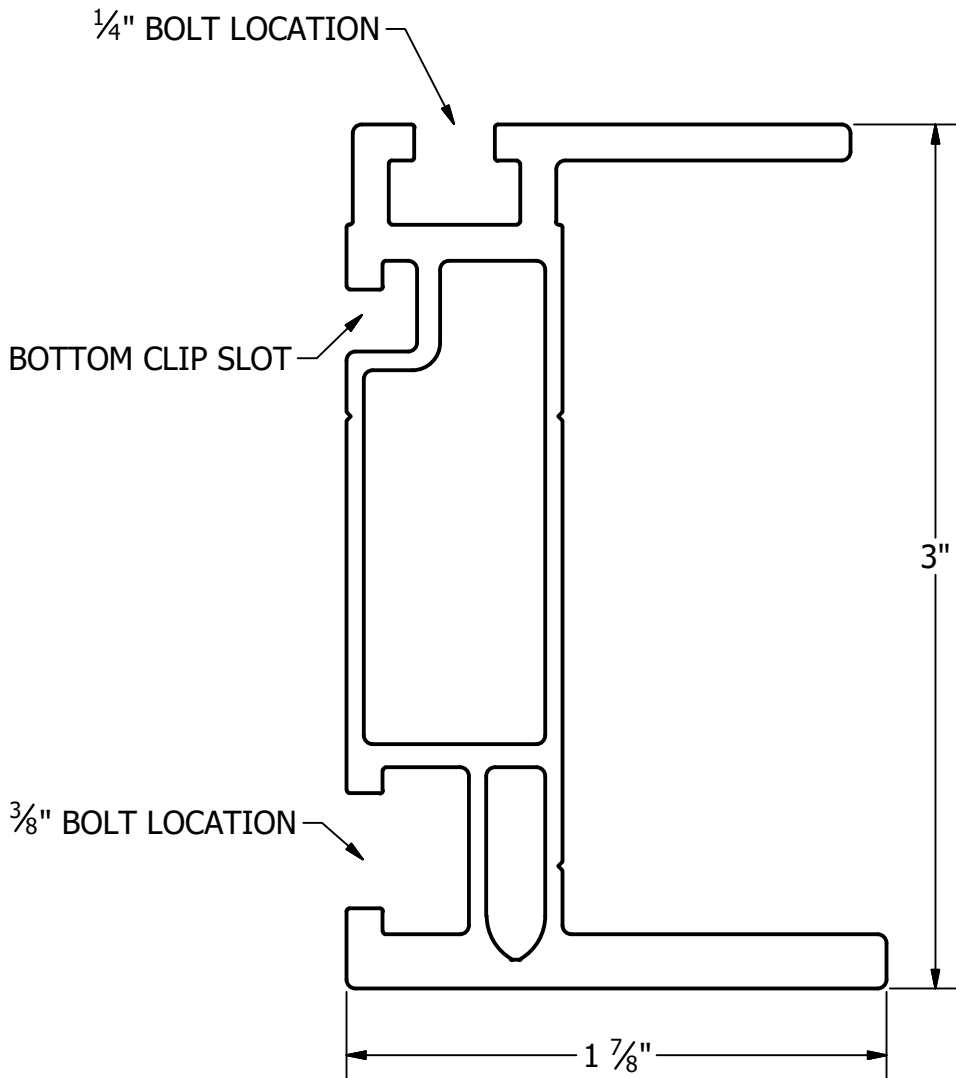

PART # TABLE		
P/N	DESCRIPTION	LENGTH
410144M	SMHD, RAIL 144" MILL	144"
410168M	SMHD, RAIL 168" MILL	168"
410204M	SMHD, RAIL 204" MILL	204"
410240M	SMHD, RAIL 240" MILL	240"

UNIRAC[®]

1411 BROADWAY BLVD. NE
 ALBUQUERQUE, NM 87102 USA
 PHONE: 505.242.6411
 WWW.UNIRAC.COM

PRODUCT LINE:	SOLARMOUNT
DRAWING TYPE:	PART DETAIL
DESCRIPTION:	HD RAIL
REVISION DATE:	9/11/2017

DRAWING NOT TO SCALE
 ALL DIMENSIONS ARE
 NOMINAL

PRODUCT PROTECTED BY
 ONE OR MORE US PATENTS

LEGAL NOTICE

SM-P03

SHEET

NOTES:

1. END CAP INCLUDED WITH EVERY END CLAMP.
2. END CAP FITS SOLARMOUNT LIGHT AND STANDARD RAIL PROFILES.

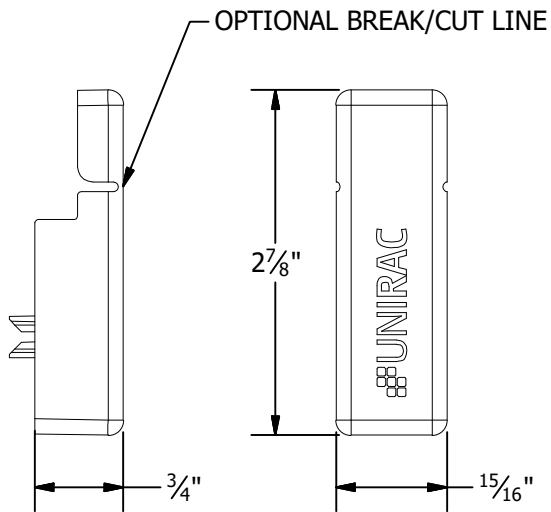
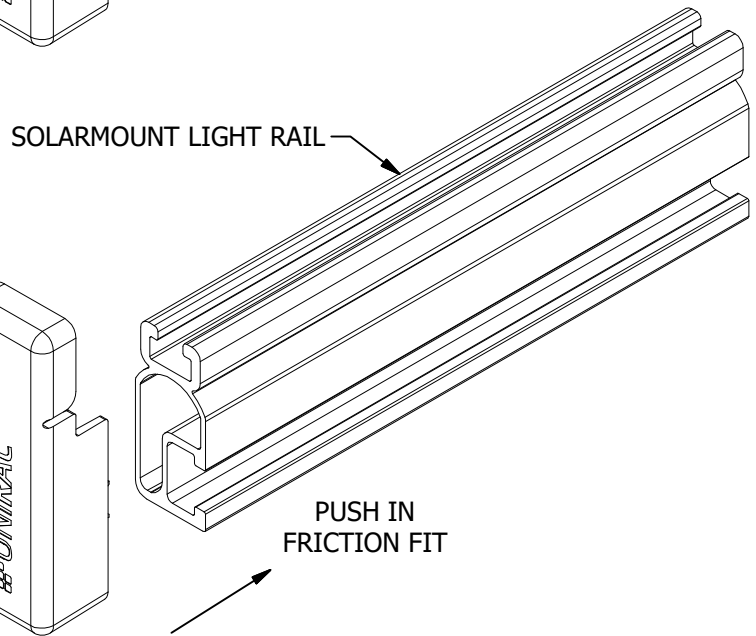
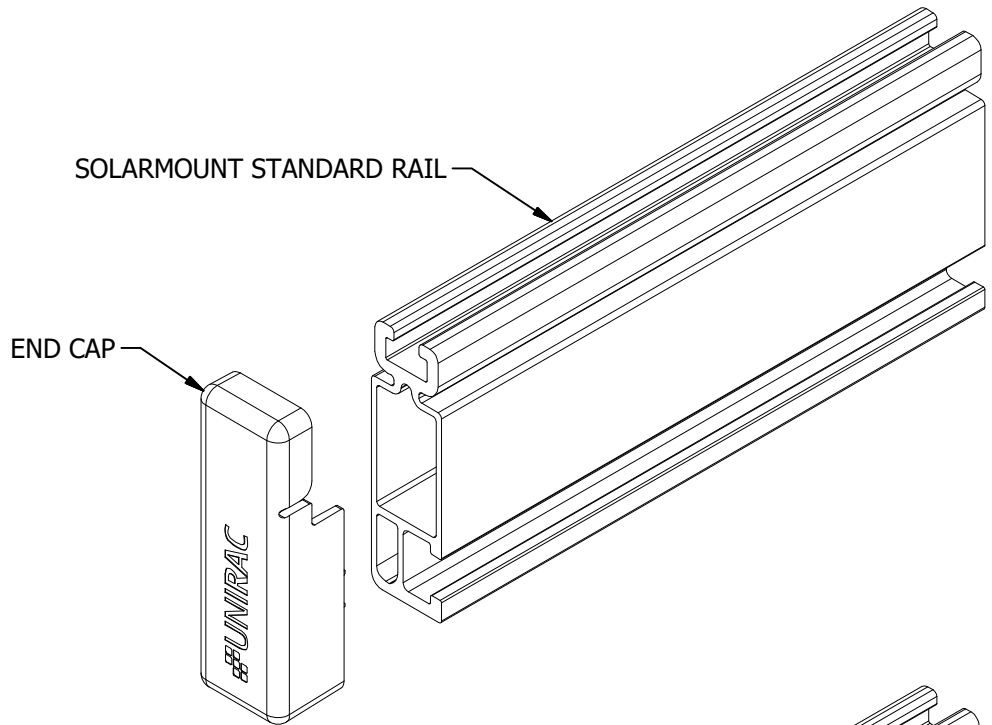

1411 BROADWAY BLVD. NE
 ALBUQUERQUE, NM 87102 USA
 PHONE: 505.242.6411
 WWW.UNIRAC.COM

PRODUCT LINE: SOLARMOUNT

DRAWING TYPE: PART DETAIL

DESCRIPTION: END CAPS

REVISION DATE: 9/27/2017

DRAWING NOT TO SCALE
 ALL DIMENSIONS ARE
 NOMINAL

PRODUCT PROTECTED BY
 ONE OR MORE US PATENTS
 LEGAL NOTICE

SM-P04

SHEET

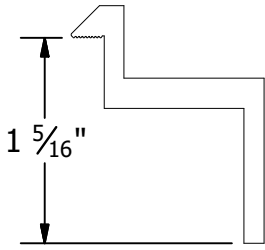

B CLAMP

30mm to 32mm Module Thickness
(1.18" to 1.26")

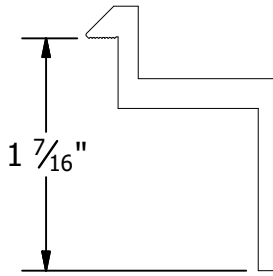

C CLAMP

33mm to 36mm Module Thickness
(1.30" to 1.42")

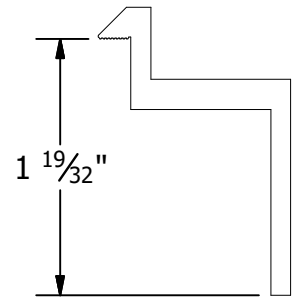

D CLAMP

38mm to 40mm Module Thickness
(1.50" to 1.57")

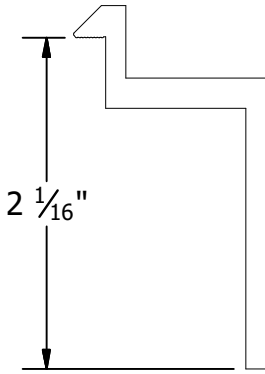

E CLAMP

50mm to 51mm Module Thickness
(1.97" to 2.00")

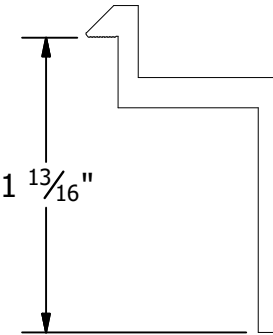

F CLAMP

45mm to 47mm Module Thickness
(1.77" to 1.85")

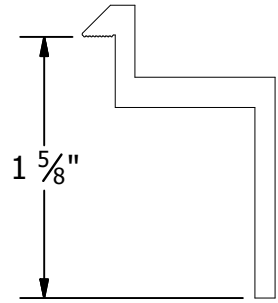

K CLAMP

39mm to 41mm Module Thickness
(1.54" to 1.61")

PART # TABLE	
P/N	DESCRIPTION
302021C	SM ENDCLAMP B CLR AL
302021D	SM ENDCLAMP B DRK AL
302022C	SM ENDCLAMP C CLR AL
302022D	SM ENDCLAMP C DRK AL
302023C	SM ENDCLAMP D CLR AL
302023D	SM ENDCLAMP D DRK AL
303024C	SM ENDCLAMP E CLR AL
302024D	SM ENDCLAMP E DRK AL
302025C	SM ENDCLAMP F CLR AL
302025D	SM ENDCLAMP F DRK AL
302026C	SM ENDCLAMP K CLR AL
302026D	SM ENDCLAMP K DRK AL

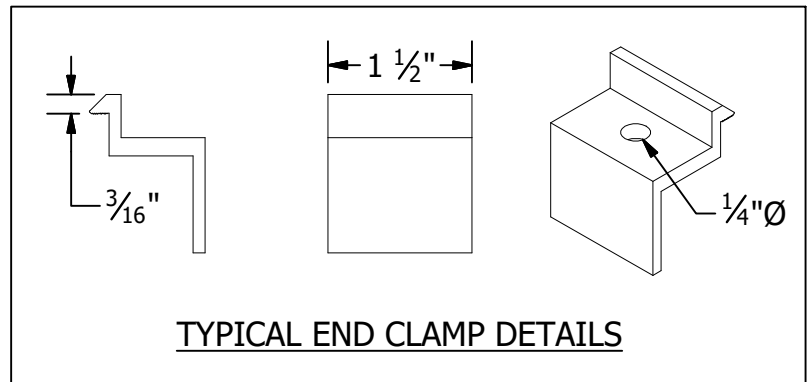

1411 BROADWAY BLVD. NE
ALBUQUERQUE, NM 87102 USA
PHONE: 505.242.6411
WWW.UNIRAC.COM

PRODUCT LINE:	SOLARMOUNT
DRAWING TYPE:	PART DETAIL
DESCRIPTION:	END CLAMPS - TOP MOUNTING
REVISION DATE:	9/27/2017

DRAWING NOT TO SCALE ALL DIMENSIONS ARE NOMINAL
PRODUCT PROTECTED BY ONE OR MORE US PATENTS LEGAL NOTICE

SM-P05
SHEET

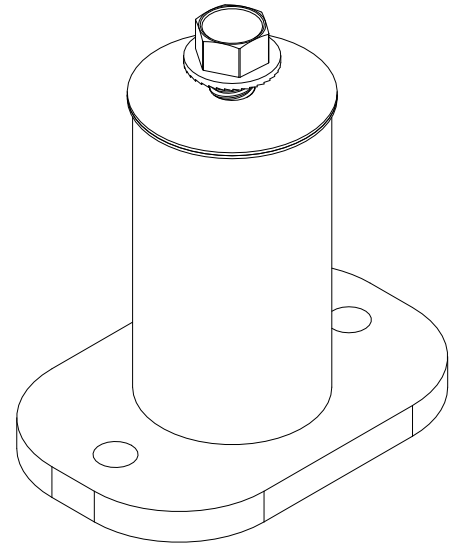
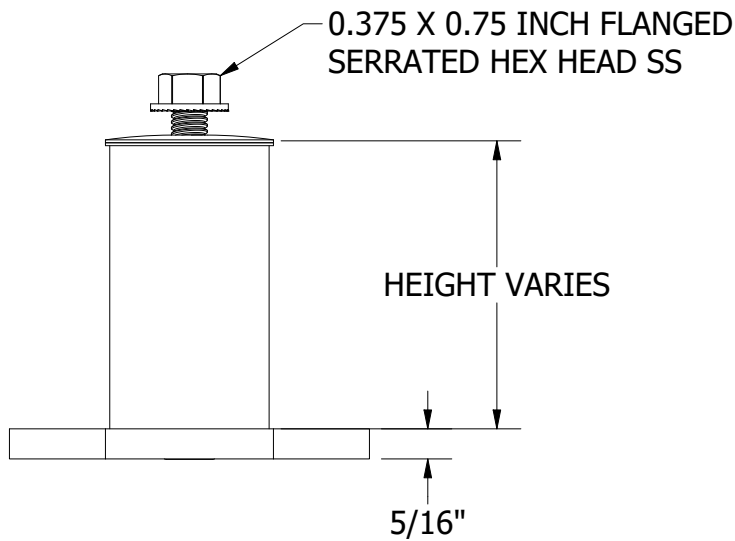
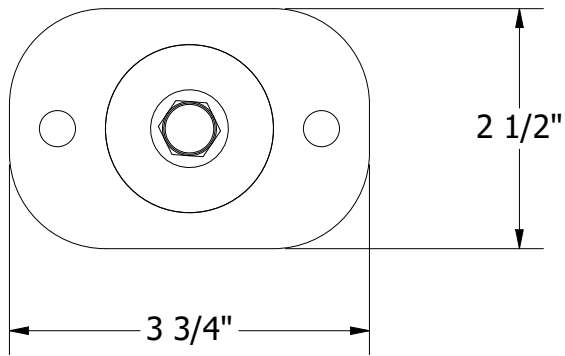

PART # TABLE	
P/N	DESCRIPTION
004300M	3" 2 PIECE STANDOFF MILL
004300D	3" 2 PIECE STANDOFF DARK
004400M	4" 2 PIECE STANDOFF MILL
004400D	4" 2 PIECE STANDOFF DARK
004600M	6" 2 PIECE STANDOFF MILL
004600D	6" 2 PIECE STANDOFF DARK
004700M	7" 2 PIECE STANDOFF MILL
004700D	7" 2 PIECE STANDOFF DARK



1411 BROADWAY BLVD. NE
 ALBUQUERQUE, NM 87102 USA
 PHONE: 505.242.6411
 WWW.UNIRAC.COM

PRODUCT LINE:	SM
DRAWING TYPE:	ASSEMBLY DETAIL
DESCRIPTION:	STANDOFF
REVISION DATE:	5/19/2020

DRAWING NOT TO SCALE
 ALL DIMENSIONS ARE
 NOMINAL

PRODUCT PROTECTED BY
 ONE OR MORE US PATENTS
 LEGAL NOTICE

SM-A12

SHEET