

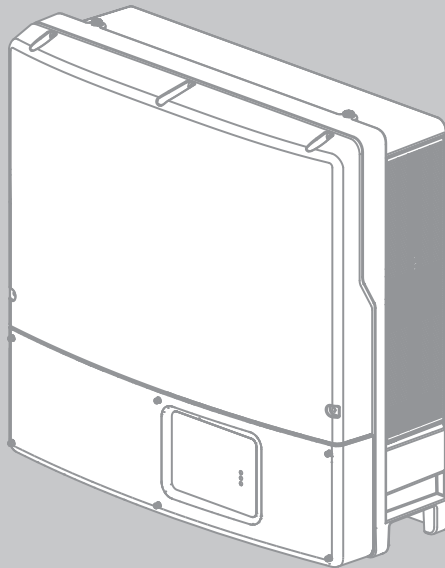

Installation Manual

**SUNNY TRIPOWER 12000TL-US / 15000TL-US /  
20000TL-US / 24000TL-US**



## Legal Provisions

Copyright © 2013 SMA America, LLC. All rights reserved.

No part of this document may be reproduced, stored in a retrieval system, or transmitted, in any form or by any means, be it electronic, mechanical, photographic, magnetic or otherwise, without the prior written permission of SMA America, LLC.

Neither SMA America, LLC nor SMA Solar Technology Canada Inc. makes representations, express or implied, with respect to this documentation or any of the equipment and/or software it may describe, including (with no limitation) any implied warranties of utility, merchantability, or fitness for any particular purpose. All such warranties are expressly disclaimed. Neither SMA America, LLC nor its distributors or dealers nor SMA Solar Technology Canada Inc. nor its distributors or dealers shall be liable for any indirect, incidental, or consequential damages under any circumstances.

(The exclusion of implied warranties may not apply in all cases under some statutes, and thus the above exclusion may not apply.)

Specifications are subject to change without notice. Every attempt has been made to make this document complete, accurate and up-to-date. Readers are cautioned, however, that SMA America, LLC and SMA Solar Technology Canada Inc. reserve the right to make changes without notice and shall not be responsible for any damages, including indirect, incidental or consequential damages, caused by reliance on the material presented, including, but not limited to, omissions, typographical errors, arithmetical errors or listing errors in the content material.

All trademarks are recognized even if these are not marked separately. Missing designations do not mean that a product or brand is not a registered trademark.

The *Bluetooth*<sup>®</sup> word mark and logos are registered trademarks owned by Bluetooth SIG, Inc. and any use of such marks by SMA America, LLC and SMA Solar Technology Canada Inc. is under license.

### **SMA America, LLC**

3801 N. Havana Street  
Denver, CO 80239 U.S.A.

### **SMA Solar Technology Canada Inc.**

2425 Matheson Blvd. E  
7th Floor  
Mississauga, ON L4W 5K4  
Canada

# Important Safety Instructions

## SAVE THESE INSTRUCTIONS

This manual contains important instructions for the following products:



- STP 12000TL-US-10 (Sunny Tripower 12000TL-US)
- STP 15000TL-US-10 (Sunny Tripower 15000TL-US)
- STP 20000TL-US-10 (Sunny Tripower 20000TL-US)
- STP 24000TL-US-10 (Sunny Tripower 24000TL-US)

This manual must be followed during installation and maintenance.

The product is designed and tested in accordance with international safety requirements, but as with all electrical and electronic equipment, certain precautions must be observed when installing and/or operating the product. To reduce the risk of personal injury and to ensure the safe installation and operation of the product, you must carefully read and follow all instructions, cautions and warnings in this manual.



## Warnings in this document

A warning describes a hazard to equipment or personnel. It calls attention to a procedure or practice, which, if not correctly performed or adhered to, could result in damage to or destruction of part or all of the SMA equipment and/or other equipment connected to the SMA equipment or personal injury.

Symbol	Description
 <b>DANGER</b>	DANGER indicates a hazardous situation which, if not avoided, will result in death or serious injury.
 <b>WARNING</b>	WARNING indicates a hazardous situation which, if not avoided, could result in death or serious injury.
 <b>CAUTION</b>	CAUTION indicates a hazardous situation which, if not avoided, could result in minor or moderate injury.
<b>NOTICE</b>	NOTICE is used to address practices not related to personal injury.

## Warnings on this product

The following symbols are used as product markings with the following meanings.

Symbol	Description
	<b>Warning regarding dangerous voltage</b> The product works with high voltages. All work on the product must only be performed as described in the documentation of the product.
	<b>Beware of hot surface</b> The product can become hot during operation. Do not touch the product during operation.
	<b>Observe the operating instructions</b> Read the documentation of the product before working on it. Follow all safety precautions and instructions as described in the documentation.

## General Warnings

### WARNING

All electrical installations must be made in accordance with the local and *National Electrical Code*® ANSI/NFPA 70 or the *Canadian Electrical Code*® CSA C22.1. This document does not and is not intended to replace any local, state, provincial, federal or national laws, regulations or codes applicable to the installation and use of the product, including without limitation applicable electrical safety codes. All installations must conform with the laws, regulations, codes and standards applicable in the jurisdiction of installation. SMA assumes no responsibility for the compliance or noncompliance with such laws or codes in connection with the installation of the product.

The product contains no user-serviceable parts.

For all repair and maintenance, always return the unit to an authorized SMA Service Center.

Before installing or using the product, read all of the instructions, cautions, and warnings in this manual.

Before connecting the product to the electrical utility grid, contact the local utility company. This connection must be made only by qualified personnel.

Wiring of the product must be made by qualified personnel only.

# Table of Contents

- 1 Information on this Document ..... 9**
- 2 Safety ..... 11**
  - 2.1 Intended Use ..... 11
  - 2.2 Skills of Qualified Persons ..... 12
  - 2.3 Safety Precautions ..... 12
- 3 Scope of Delivery ..... 14**
- 4 Product Description ..... 15**
  - 4.1 Sunny Tripower ..... 15
  - 4.2 Type Label and Additional Label ..... 16
  - 4.3 SMA Webconnect Data Module ..... 17
  - 4.4 485 Data Module ..... 17
  - 4.5 Arc-Fault Circuit Interrupter (AFCI) ..... 18
  - 4.6 SMA OptiTrac Global Peak ..... 18
  - 4.7 SMA Grid Guard ..... 18
- 5 Mounting ..... 19**
  - 5.1 Requirements for Mounting ..... 19
  - 5.2 Mounting the Inverter ..... 22
- 6 Electrical Connection ..... 25**
  - 6.1 Safety during Electrical Connection ..... 25
  - 6.2 Overview of the Connection Area ..... 27
    - 6.2.1 View from Below ..... 27
    - 6.2.2 Interior View ..... 28
  - 6.3 AC Connection ..... 28
    - 6.3.1 Requirements for the AC Connection ..... 28
    - 6.3.2 Connecting the Inverter to the Utility Grid ..... 29
  - 6.4 DC Connection ..... 31
    - 6.4.1 Requirements for the DC Connection ..... 31
    - 6.4.2 Connecting the PV Array ..... 32
  - 6.5 Additional Grounding of the Enclosure ..... 33

<b>7</b>	<b>Commissioning</b> .....	<b>35</b>
<b>8</b>	<b>Configuration</b> .....	<b>36</b>
8.1	Connecting the Inverter to the Network.....	36
8.2	Registering the Inverter in Sunny Portal.....	36
8.3	Changing the PV System Time and PV System Password.....	37
8.4	Changing Operating Parameters.....	37
8.5	Activating and Setting SMA OptiTrac Global Peak.....	38
8.6	Adjustable Parameters .....	38
<b>9</b>	<b>Disconnecting the Inverter from Voltage Sources</b> .....	<b>40</b>
<b>10</b>	<b>Troubleshooting</b> .....	<b>41</b>
10.1	LED Signals.....	41
10.2	Event Messages.....	41
10.2.1	Information .....	41
10.2.2	Warnings and Errors.....	43
10.3	Cleaning the Inverter.....	49
10.4	Cleaning the Fans .....	49
10.4.1	Cleaning the Fan at the Bottom.....	49
10.4.2	Cleaning the Fan on the Left-Hand Side of the Enclosure .....	50
10.5	Checking the Fans.....	52
10.6	Checking the PV System for Ground Faults.....	53
10.7	Resetting the Operation Inhibition after Detection of an Arc Fault ..	54
10.8	Procedure for Receiving a Replacement Device .....	55
<b>11</b>	<b>Decommissioning the Inverter</b> .....	<b>59</b>
<b>12</b>	<b>Technical Data</b> .....	<b>61</b>
12.1	DC/AC .....	61
12.1.1	Sunny Tripower 12000TL-US / 15000TL-US .....	61
12.1.2	Sunny Tripower 20000TL-US / 24000TL-US .....	62
12.2	General Data .....	64
12.3	Protective Devices.....	65
12.4	Climatic Conditions .....	65
12.5	Equipment.....	65

12.6 Torques ..... 65

12.7 Data Storage Capacity..... 66

**13 Accessories ..... 67**

**14 Compliance Information..... 68**

**15 Contact..... 69**



# 1 Information on this Document

## Validity

This document is valid for the following device types:

- STP 12000TL-US-10 (Sunny Tripower 12000TL-US)
- STP 15000TL-US-10 (Sunny Tripower 15000TL-US)
- STP 20000TL-US-10 (Sunny Tripower 20000TL-US)
- STP 24000TL-US-10 (Sunny Tripower 24000TL-US)

## Target Group



This document is intended for qualified persons. Only persons with the appropriate skills are allowed to perform the activities described in this document (see Section 2.2 "Skills of Qualified Persons", page 12).

## Additional Information

Links to additional information can be found at [www.SMA-Solar.com](http://www.SMA-Solar.com):

Document title	Document type
Sunny Explorer	User Manual
Webconnect Systems in Sunny Portal	User Manual
Parameter Description	Technical Information
Parameter Settings	Technical Information
Efficiency and Derating	Technical Information
Leading Leakage Currents	Technical Information
Shade Management	Technical Information
Module Technology	Technical Information

## Symbols

Symbol	Explanation
	Information that is important for a specific topic or goal, but is not safety-relevant
<input type="checkbox"/>	Indicates a requirement for meeting a specific goal
<input checked="" type="checkbox"/>	Desired result
	A problem that might occur

## Nomenclature

<b>Complete designation</b>	<b>Designation in this document</b>
SMA America Production, LLC	SMA
SMA Solar Technology Canada Inc.	SMA
SMA Speedwire	Speedwire
PV system	PV system
Torque	Torque
Sunny Tripower 12000TL-US / 15000TL-US / 20000TL-US / 24000TL-US	Sunny Tripower, inverter
SMA Connection Unit 1000-US	Connection Unit

## 2 Safety

### 2.1 Intended Use

The Sunny Tripower is a transformerless PV inverter with two MPP trackers which converts the direct current of the PV array to grid-compliant three-phase current and feeds it into the utility grid.

#### **i** No galvanic isolation

- The Sunny Tripower is not equipped with a transformer and therefore has no galvanic isolation.
- The AC output/neutral is not bonded to ground inside of the inverter.

The product is suitable for indoor and outdoor use.

The Sunny Tripower must only be operated with PV arrays (PV modules and cabling) that are approved by the electrical standards applicable on-site and the *National Electrical Code*® ANSI/NFPA 70 or the *Canadian Electrical Code*® CSA C22.1. The PV modules used must be suitable for use with the Sunny Tripower.

To protect the PV system against excessive reverse currents under fault conditions, the *National Electrical Code*®, Section 690.9, requires overcurrent protection for PV source circuits where possible short-circuit currents exceed the ampacity of source circuit conductors or the maximum series fuse rating of the PV modules. Typically, this requires string fusing where more than two strings are combined in parallel. Where overcurrent protection is required, *National Electrical Code*®, Section 690.35, requires that both positive and negative conductors have overcurrent protection for ungrounded PV arrays.

SMA offers the SMA Connection Unit which is equipped with fuse holders for string fuses for up to eight strings and with a DC load-break switch. The SMA Connection Unit combines up to four strings to each of two output circuits. These two output circuits can be connected to the two MPP tracker inputs of the Sunny Tripower (für weitere Informationen siehe Installationsanleitung der SMA Connection Unit-Us unter [www.SMA-Solar.com](http://www.SMA-Solar.com)).

PV modules with a high capacity to ground may only be used if their coupling capacity does not exceed 3.5  $\mu\text{F}$ .

All components must remain within their permitted operating ranges at all times.

For safety reasons, it is forbidden to modify the product or install components that are not explicitly recommended or distributed by SMA for this product.

The product must only be used in countries for which it is approved or released by SMA and the grid operator.

The Sunny Tripower is not equipped with a transformer and therefore has no galvanic isolation. Do not use grounded PV modules with the Sunny Tripower. Only ground the mounting frame of the PV modules. If you connect grounded PV modules to the inverter, the error **Insulation resistance > Check generator** occurs.

Use this product only in accordance with the information provided in the enclosed documentation and with the locally applicable standards and directives. Any other use can result in personal injury or property damage.

- Do not install the product on flammable construction materials.
- Do not mount the product in areas containing highly flammable materials.
- Do not mount the product in potentially explosive atmospheres.

The enclosed documentation is an integral part of this product.

- Read and observe the documentation.
- Keep the documentation in a convenient place for future reference.

## 2.2 Skills of Qualified Persons

The tasks described in this document must be performed by qualified persons only. Qualified persons must have the following skills:

- Knowledge of how an inverter works and is operated
- Training in how to deal with the dangers and risks associated with installing and using electrical devices and systems
- Training in the installation and commissioning of electrical devices and systems
- Knowledge of the applicable standards and directives
- Knowledge of and compliance with this document and all safety precautions

## 2.3 Safety Precautions

This section contains safety precautions that must be observed at all times when working on or with the product.

To prevent personal injury and property damage and to ensure long-term operation of the product, read this section carefully and follow all safety precautions at all times.

**⚠ DANGER****Danger to life due to electric shock when operating the inverter**

High voltages are present on the inverter and its components. Death or serious injuries when touching live components.

- Do not touch any live components.
- Prior to performing any work on the inverter, disconnect it from all voltage sources as described in this document (see Section 9, page 40), and wait five minutes.
- Observe the safety messages on the inverter.

**⚠ DANGER****Danger to life due to electric shock in case of a ground fault**

If a ground fault occurs, parts of the system may still be live. Death or serious injuries due to contact with live components

- Ensure that no voltage is present and wait five minutes before touching any parts of the PV system or the inverter.

**⚠ CAUTION****Risk of burns from hot surfaces**

The surface of the inverter can get very hot. Touching the surface can result in burns.

- Mount the inverter in such a way that it cannot be touched inadvertently.
- Do not touch hot surfaces.
- Wait 30 minutes for the surface to cool sufficiently.
- Observe the safety messages on the inverter.

***NOTICE*****Damage to the inverter due to moisture and dust intrusion**

Dust or moisture intrusion can damage the inverter and impair its functionality.

- Close all enclosure openings of the inverter tightly.
- Never open the inverter when it is raining or snowing, or the humidity is over 95%.

### 3 Scope of Delivery

Check the scope of delivery for completeness and any externally visible damage. Contact your distributor if the scope of delivery is incomplete or damaged.

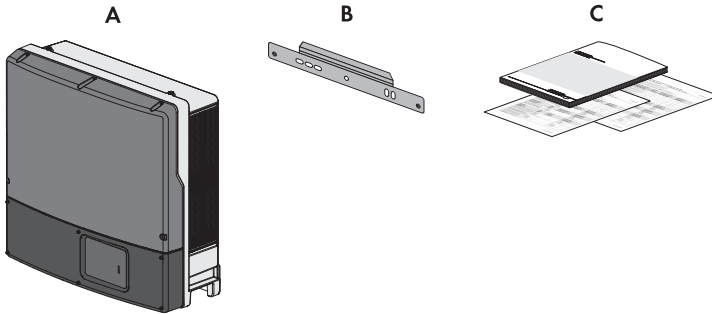

Figure 1: Components included in the scope of delivery

Position	Quantity	Designation
A	1	Inverter
B	1	Wall mounting bracket
C	1	Installation manual, Production Test Report, supplementary sheet with the default settings

## 4 Product Description

### 4.1 Sunny Tripower

The Sunny Tripower is a transformerless PV inverter with two MPP trackers which converts the direct current of the PV array to grid-compliant three-phase current and feeds it into the utility grid.

#### **i** No galvanic isolation

- The Sunny Tripower is not equipped with a transformer and therefore has no galvanic isolation. The open-circuit voltage of the PV modules must be larger than or equal to the peak value of the AC line voltage.
- The AC output/neutral is not bonded to ground inside of the inverter.

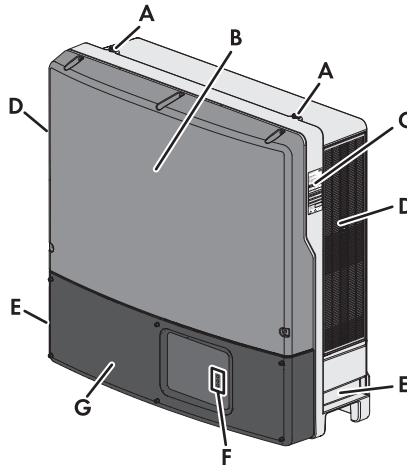







Figure 2: Design of the Sunny Tripower

Position	Designation
A	Thread for screwing in the eye bolts for transport with a crane
B	Upper enclosure lid
C	Type label
D	Ventilation grid
E	Recessed grips
F	LEDs
G	Lower enclosure lid

## Symbols on the Inverter

Symbol	Explanation
	<b>Green LED: inverter</b> The green LED indicates the operating state of the inverter.
	<b>Red LED: observe the documentation</b> The red LED indicates an error. Read this document for instructions on how to correct the error.
	<b>Blue LED: communication</b> The blue LED indicates that a wireless communication is enabled.
	<b>transformerless</b>
	<b>Equipment Grounding Terminal</b>



## 4.2 Type Label and Additional Label

The type label uniquely identifies the inverter. The type label is located on the right-hand side of the enclosure. You will find the following information on the type label:



- Device type (Model)
- Serial number (Serial No.)
- Date of manufacture
- Device-specific characteristics

You will require the information on the type label to use the inverter safely and when seeking customer support from the SMA Service Line. The type label must be permanently attached to the inverter.

### Symbols on the Type Label

Symbol	Explanation
	<b>Danger to life due to high voltages</b> The product operates at high voltages. All work on the product must be carried out by qualified persons only.
	<b>Risk of burns from hot surfaces</b> The product can get hot during operation. Avoid contact during operation. Allow the product to cool down sufficiently before carrying out any work. Wear personal protective equipment such as safety gloves.



Symbol	Explanation
	Observe the documentation. Observe all documentation supplied with the product.
	FCC designation The product complies with the requirements of the applicable FCC standards.
	UL certification mark UL1741 is the standard applied by Underwriters Laboratories to the product to certify that it meets the requirements of the <i>National Electrical Code</i> ®, the <i>Canadian Electrical Code</i> ® CSA C22.1 and IEEE-929-2000. IEEE 929-2000 provides recommendations regarding the proper equipment and functionality necessary to ensure compatible operation when power generation is connected to the utility grid.

### Additional Label for Registration in Sunny Portal

On the right-hand side of the enclosure above the recessed grip is an additional label with information for registration in Sunny Portal:

- Internet address of the system setup assistant
- Identification key (PIC)
- Registration ID (RID)

## 4.3 SMA Webconnect Data Module

The inverter is equipped as standard with an SMA Webconnect Data Module and can communicate with special SMA communication products or other inverters. The SMA Webconnect Data Module allows you to use the Webconnect function and to register your PV system in Sunny Portal. Sunny Portal can call up the latest data from your inverter (for information on the logging of your PV systems in Sunny Portal, refer to the Sunny Portal user manual at [www.SMA-Solar.com](http://www.SMA-Solar.com)).

Class 1 wiring methods are to be used for field wiring connection to the terminals of the SMA Webconnect Data Module.

## 4.4 485 Data Module

The inverter can be retrofitted with a 485 data module. The 485 data module enables the setup of cable-connected RS485 communication for SMA inverters (refer to the installation manual of the 485 data module at [www.SMA-Solar.com](http://www.SMA-Solar.com)).

Class 1 wiring methods are to be used for field wiring connection to the terminals of the SMA Webconnect Data Module.

## 4.5 Arc-Fault Circuit Interrupter (AFCI)

In accordance with the *National Electrical Code*<sup>®</sup>, Article 690.11, the inverter has a system for arc fault detection and interruption.

An electric arc with a power of 300 W or greater must be interrupted by the AFCI in the time specified by UL 1699B. A tripped AFCI can only be reset manually. The 2011 edition of the *National Electrical Code*<sup>®</sup>, Section 690.11, stipulates that newly installed PV systems attached to a building must be fitted with a means of detecting and disconnecting serial electric arcs on the DC side. If you prefer not to have that function, you can deactivate the arc-fault circuit interrupter via a communication product (see Section 8.4 "Changing Operating Parameters", page 37).

## 4.6 SMA OptiTrac Global Peak

SMA OptiTrac Global Peak is a further development of the MPP tracking feature SMA OptiTrac. MPP tracking is a feature that determines the highest usable power in the PV system at any given time. The power generated by the PV system depends on the level of solar irradiation and the temperature of the PV modules. As a result, the optimum operating point for maximum power (MPP) changes constantly throughout the day.

SMA OptiTrac enables the operating point of the inverter to follow the MPP precisely at all times. SMA OptiTrac Global Peak also means that the inverter can detect the presence of multiple maximum power points in the available operating range, such as can occur in partially shaded PV strings in particular. The available power of the partially shaded PV strings can therefore be almost completely fed into the utility grid.

SMA OptiTrac Global Peak is deactivated by default and in the case of partially shaded PV modules should be activated and set via a communication product Activating and Setting SMA OptiTrac Global Peak.

## 4.7 SMA Grid Guard

SMA Grid Guard acts as an automatic disconnection device between a grid-parallel generator (e.g. a PV system or small wind turbine system) and the utility grid.

SMA Grid Guard is also a grid monitoring concept which detects errors by permanently monitoring grid impedance, grid voltage, and power frequency. SMA Grid Guard For example, detects when a stand-alone grid is formed and disconnects the inverter from the utility grid immediately.

In some countries, the connection conditions require a device which protects grid-relevant operating parameters against unauthorized changes. SMA Grid Guard performs this function.

Some country data sets are automatically protected after the first ten feed-in hours. The protected country data sets can only be changed via a communication product by entering a personal access code, the SMA Grid Guard code, after ten feed-in hours (for information on changing parameters, see the manual for the communication product). You will receive the SMA Grid Guard code from SMA (application for the SMA Grid Guard Code, see the Certificate "Order Form for the SMA Grid Guard Code" at [www.SMA-Solar.com](http://www.SMA-Solar.com)).

## 5 Mounting

### 5.1 Requirements for Mounting

#### Requirements for the mounting location:

#### **⚠ WARNING**

#### **Danger to life due to fire or explosion**

Despite careful construction, electrical devices can cause fires.

- Do not mount the product in areas containing highly flammable materials or gases.
  - Do not mount the product in potentially explosive atmospheres.
- 
- Do not mount the inverter on a pillar.
  - The inverter must be mounted on a solid surface (e.g. concrete, brickwork, free-standing constructions).
  - Do not install the inverter in a living area.
  - The mounting location must be suitable for the weight and dimensions of the inverter (see Section 12 "Technical Data", page 61).
  - The mounting location should be freely and safely accessible at all times without the necessity for any auxiliary equipment (e.g. scaffolding or lifting platforms). Non-fulfillment of these criteria may restrict servicing.
  - The inverter can be mounted in a position that is directly exposed to solar irradiation. However, it is possible that the inverter may become overheated and its power be reduced as a result.
  - Climatic conditions must be met (see Section 12 "Technical Data", page 61).
  - The ambient temperature must be between  $-25^{\circ}\text{C}$  and  $60^{\circ}\text{C}$  ( $-13^{\circ}\text{F}$  and  $+140^{\circ}\text{F}$ ) to ensure optimal operation of the inverter.

Dimensions for wall mounting:

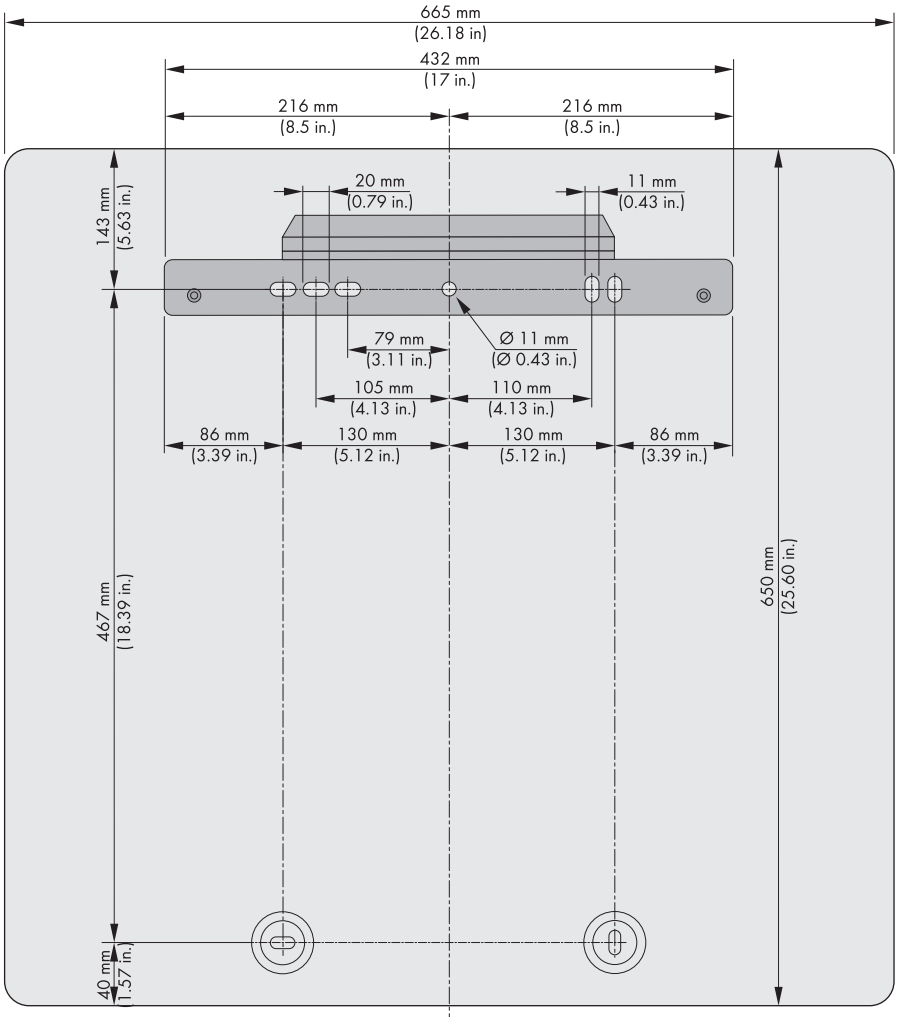

**Recommended clearances:**

To guarantee optimal operation and adequate heat dissipation for the inverter, the following requirements for clearances should be observed. This will prevent the inverter power output from being reduced due to excessive temperatures. However, smaller clearances are permitted without causing any risk.

**i Prescribed clearances**

Under certain conditions, the *National Electrical Code*® specifies greater clearances.

Ensure that the prescribed clearances in accordance with the *National Electrical Code*®, Paragraph 110.26 and *Canadian Electrical Code*® CSA C22.1 are adhered to.

- Observe the recommended clearances to walls as well as to other inverters or objects.
- Ensure adequate clearance on the right-hand side of the inverter below the fan.
- If multiple inverters are mounted in areas with high ambient temperatures, increase the clearances between the inverters and ensure an adequate fresh-air supply, if possible.

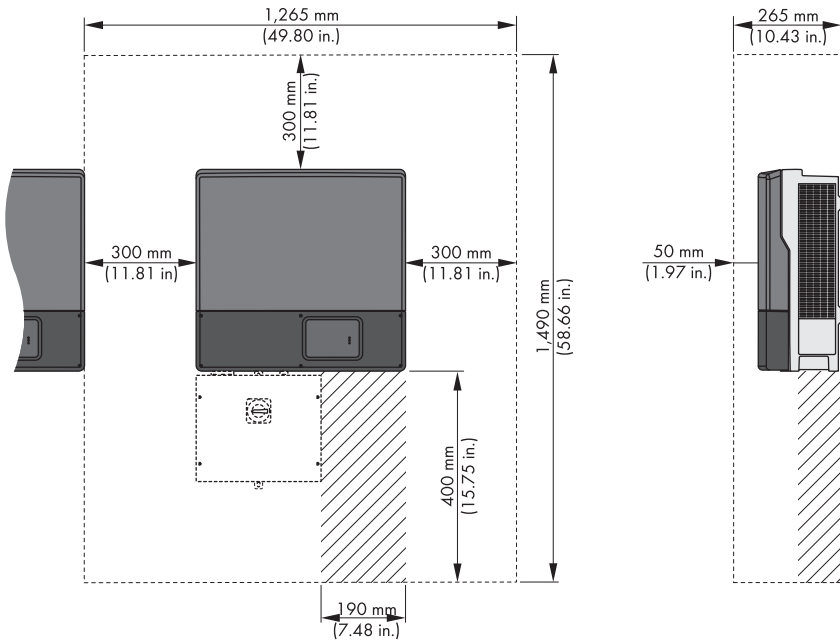

**Permitted mounting positions:**

- The inverter must be mounted in one of the permitted mounting positions. This will ensure that no moisture can penetrate the inverter. Make sure that the LEDs are always visible in order to identify LED signals.

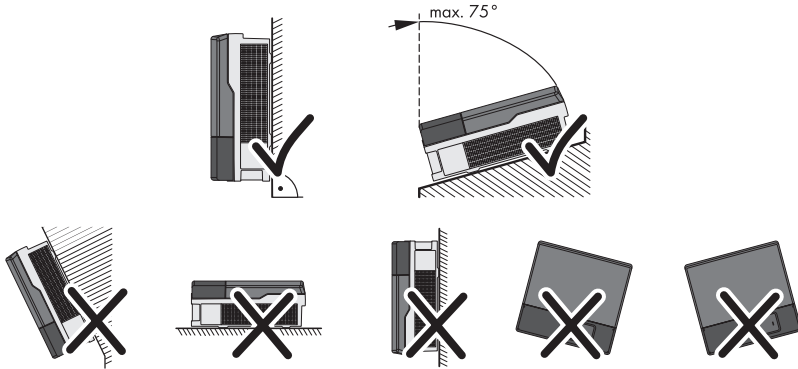
**5.2 Mounting the Inverter****Additionally required mounting material (not included in the scope of delivery):**

- At least two screws that are suitable for the foundation
- At least two washers that are suitable for the screws
- At least two screw anchors that are suitable for the support surface and the screws
- For transporting the inverter with a crane: two eye bolts
- To secure the inverter from being lifted off: two screws, washers and screw anchors that are suitable for the support surface

### ⚠ CAUTION

#### Risk of injury when lifting the inverter, or if it is dropped

The inverter is heavy (see Section 12 "Technical Data", page 61). There is risk of injury if the inverter is lifted incorrectly or dropped while being transported or when attaching it to or removing it from the wall mounting bracket.

- Carry and lift the inverter upright with several people without tilting it. With one hand grasp the recessed grip, and with the other hand support the top part of the enclosure. This will prevent the inverter tipping forward.
- If the inverter is to be transported and lifted with a crane, remove the filler plugs on the top of the inverter and screw the eye bolts into the threads.

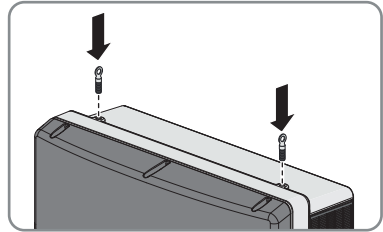
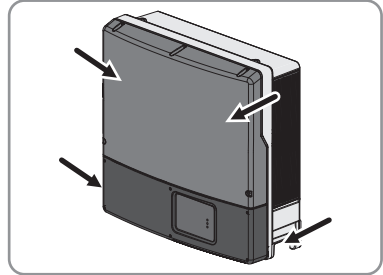

### ⚠ CAUTION

#### Risk of burns from hot surfaces

During operation, the inverter can get hot.

- Mount the inverter in such a way that it cannot be touched inadvertently during operation.

#### Procedure:

##### 1. ⚠ WARNING

#### Risk of electric shock if electric cables and other supply lines are damaged by drilling

- Before drilling, ensure that there are no electric cables and supply lines in the wall that could be damaged.
2. Align the wall mounting bracket horizontally on the wall and use it to mark the position of the drill holes. Use at least one hole on the right-hand and left-hand side in the wall mounting bracket.
  3. If the inverter should be secured from accidentally being lifted off of the wall mounting bracket, mark the position of the drill hole for the screw that attaches the inverter to the wall mounting bracket. Observe the dimensions of the drill holes in the enclosure at the bottom of the inverter.
  4. Drill the holes.

5. Plug one screw anchor into each hole.
6. Secure the wall mounting bracket horizontally using screws and washers.
7. Hook the inverter into the wall mounting bracket.

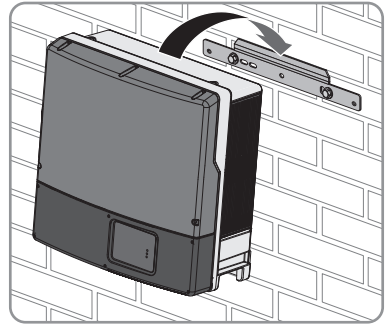

8. When using a crane to transport the inverter, remove the eye bolts after hooking the inverter into the bracket and attach the filler plugs again.
9. In order to secure the inverter from being lifted off the wall accidentally, attach it to the wall with suitable mounting material. Use both of the lower drill holes on the rear panel of the inverter.

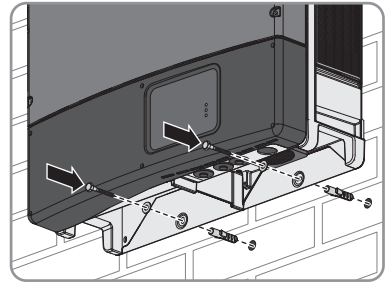

10. Ensure that the inverter is securely in place.



## 6 Electrical Connection

### 6.1 Safety during Electrical Connection

#### **⚠ DANGER**

##### **Danger to life due to electric shock when operating the inverter**

High voltages are present on the inverter and its components. Death or serious injuries when touching live components.

- Do not touch any live components of the inverter.
- Prior to performing any work on the inverter, disconnect it from all voltage sources as described in this document (see Section 9, page 40), and wait five minutes.
- Only connect the inverter as described in this manual.
- Observe the safety messages on the inverter.

#### **⚠ DANGER**

##### **Danger to life due to electric shock in case of a ground fault**

If a ground fault occurs, parts of the system may still be live. Death or serious injuries due to contact with live components

- Ensure that no voltage is present and wait five minutes before touching any parts of the PV system or the inverter.

#### **⚠ CAUTION**

##### **Risk of fire**

- To reduce the risk of fire, connect only to a circuit provided with 50 A maximum branch-circuit overcurrent protection in accordance with the *National Electrical Code*<sup>®</sup> (NE, ANSI/NFPA 70).

#### **NOTICE**

##### **Damage to the seal of the enclosure lid in sub-zero conditions**

When opening the Sunny Tripower during frost, the seal of the enclosure lid can be damaged. There may be an ingress of moisture damaging the Sunny Tripower.

- Do not open the inverter when the ambient temperature is below -5 °C (23 °F). If a layer of ice has formed on the seal of the lid in sub-zero conditions, remove it prior to opening the inverter (e.g. by melting the ice with warm air). Observe the applicable safety regulations.

**NOTICE****Damage to the inverter due to moisture ingress during electrical installation**

- Never open the inverter when it is raining or snowing, or the humidity is over 95%.
- For attaching the conduits to the enclosure, only use UL-listed rain-tight conduit fittings or UL-listed conduit fittings for wet locations complying with UL514B.
- Seal all unused openings tightly.

**NOTICE****Damage to the inverter due to electrostatic discharge**

Touching electronic components can cause damage to or destroy the inverter through electrostatic discharge.

- Ground yourself before touching any component.

**NOTICE****Ground faults, unreliable and highly resistive connections due to *Wire Nuts*<sup>®</sup>**

Potential damage to or failure of the inverter.

- Do not use *Wire Nuts*<sup>®</sup>.

***i* Electrical installations**

All electrical installations must be carried out in accordance with the local standards and the *National Electrical Code*<sup>®</sup> ANSI/NFPA 70 or the *Canadian Electrical Code*<sup>®</sup> CSA C22.1.

- Before connecting the inverter to the utility grid, contact your local grid operator. The electrical connection of the inverter must be carried out by qualified persons only.
- Ensure that no cables used for electrical connection are damaged.

## 6.2 Overview of the Connection Area

### 6.2.1 View from Below

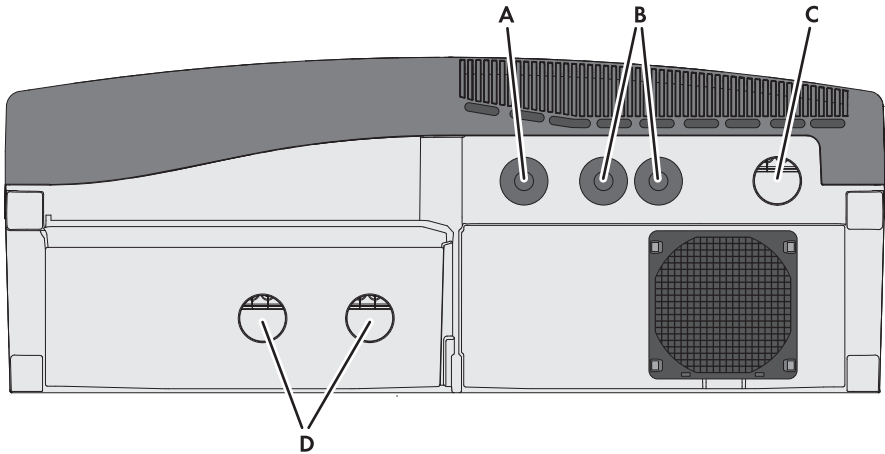

Figure 3: Enclosure openings at the bottom of the inverter

Position	Designation
A	Enclosure opening with filler plug for communication connection (diameter: 27.8 mm to 28.0 mm (1.09 in. to 1.1 in.))
B	Enclosure opening with filler plug for Ethernet connection (diameter: 27.8 mm to 28.0 mm (1.09 in. to 1.1 in.))
C	Enclosure opening for AC connection (diameter: 34.5 mm to 34.7 mm (1.36 in. to 1.37 in.))
D	Enclosure openings for DC connection (diameter: 34.5 mm to 34.7 mm (1.36 in. to 1.37 in.))

## 6.2.2 Interior View

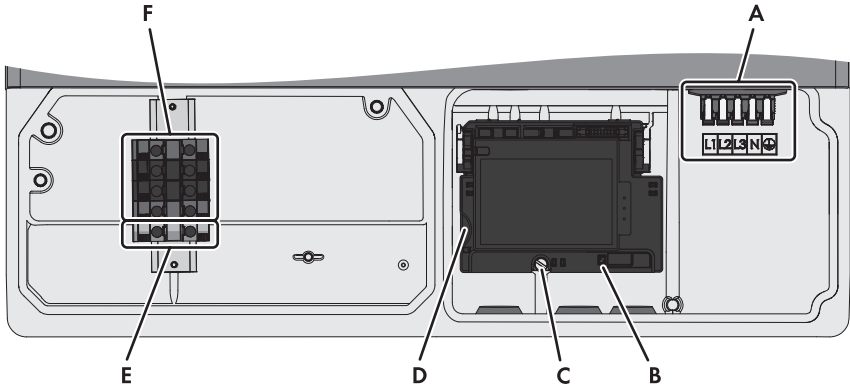

Figure 4: Connection areas in the interior of the inverter

Position	Designation
A	Connecting terminal plate for AC connection
B	Switch for changing the language to English for service purposes
C	Screw to release and attach the communication board
D	Slot for the SD memory card, for service purposes only
E	Terminal for equipment grounding and grounding electrode conductor
F	Connecting terminal plate for DC connection

## 6.3 AC Connection

### 6.3.1 Requirements for the AC Connection

**Additionally required material (not included in the scope of delivery):**

- 1 metal conduit: 25.4 mm (1 in.)
- 1 UL-listed rain-tight conduit fitting for wet locations: 25.4 mm (1 in.)

**Cable requirements:**

- The AC cable must be approved for temperatures of over +90°C (+194°F).
- The AC cable must be designed in accordance with the local installation requirements.
- The AC cable must be made of solid wire or stranded wires.
- Conductor cross-section: 10 mm<sup>2</sup> to 16 mm<sup>2</sup> (8 AWG to 6 AWG)
- Cable type: copper wire
- The maximum cable length subject to conductor cross-section must be observed.

**Load-break switch and cable protection:****NOTICE****Damage to the inverter due to the use of screw-type fuses as load-break switches**

Screw-type fuses are not suitable as load-break switches.

- Do not use screw-type fuses as load-break switches.
  - Use a load-break switch or a circuit breaker as a load-disconnection unit.
- In PV systems with multiple inverters, protect each inverter with a separate three-phase circuit breaker. Observe the maximum permissible fuse protection (see Section 12 "Technical Data", page 61). This will prevent residual voltage being present at the corresponding cable after disconnection.
- Loads installed between the inverter and the circuit breaker must be fused separately.
- The overcurrent protection for the AC output circuit is to be provided by others.

**6.3.2 Connecting the Inverter to the Utility Grid****Requirements:**

- All electrical installations must be carried out in accordance with the local standards and the *National Electrical Code*® ANSI/NFPA 70 or the *Canadian Electrical Code*® CSA C22.1.
- The DC input and AC output circuits are isolated from the enclosure and that system grounding, if required by Section 250 of the *National Electrical Code*®, ANSI/NFPA 70, is the responsibility of the installer.
- The AC cable must be protected using a load-break switch or a listed circuit breaker (see *National Electrical Code*®, ANSI/NFPA 70).
- The country data set must be set correctly (see Section 8.4, page 37).
- The connection requirements of the grid operator must be met.
- The grid voltage must be within the permissible range. The exact operating range of the inverter is specified in the operating parameters.

**Procedure:**

1.  **DANGER**

**Danger to life due to electric shock**

- Ensure that the three-pole circuit breaker is switched off and cannot be reconnected.
2. Release all screws of the lower enclosure lid using an Allen key (AF 3).
  3. Lift and remove the lower enclosure lid from below.

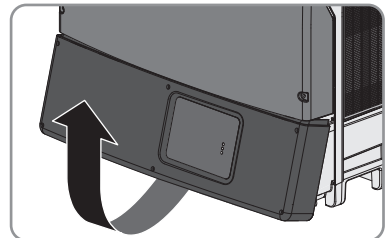

4. Remove the adhesive tape from the enclosure opening for the AC connection.

5. **NOTICE**

**Damage to the inverter due to moisture and dust intrusion**

Electronic components in the inverter can be destroyed or damaged as a result of dust or moisture intrusion.

- Do not enlarge the enclosure opening.

6. Insert the conduit fitting into the opening and tighten from the inside using the counter nut.

7. Attach the conduit to the enclosure opening.

8. Insert the AC cable through the conduit into the inverter.

9. Strip the cable insulation by 12 mm to 13 mm (0.5 in.)

10. Open all locking levers of the connecting terminal plate right up to the stop.

11. **CAUTION**

**Risk of fire if two conductors are connected to one terminal**

If you connect two conductors to a terminal, a fire can occur due to a bad electrical connection.

- Never connect more than one conductor per terminal.

12. Connect the equipment grounding conductor to the terminal  $\oplus$ .

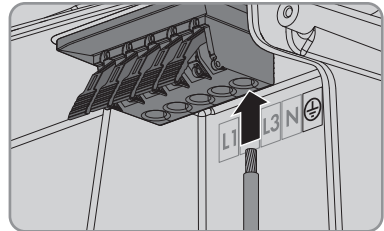

13. Connect the conductor N to the terminal **N**.

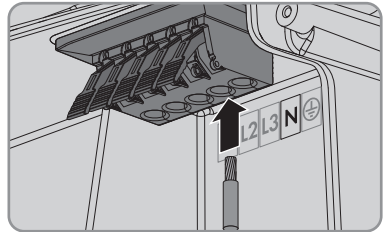

14. Connect the conductors L1, L2 and L3 to the terminals **L1**, **L2** and **L3** according to the label. Ensure that the assignment is correct.

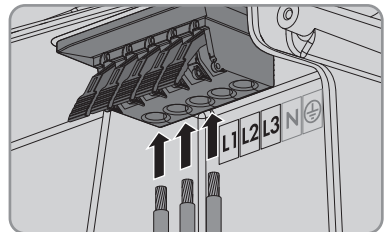

## 15. **⚠ CAUTION**

### **Danger of crushing when locking levers snap shut**

The locking levers close by snapping down fast and hard.

- Press the locking levers of the connecting terminal plate for the AC cable down with your thumb only. Do not grip the entire connecting terminal plate for the AC cable between finger and thumb and keep fingers out from under the locking levers.

16. Ensure that the correct conductors are assigned to all the terminals.

17. Ensure that all locking levers of the connecting terminal plate are closed and all conductors are tightly connected.

## 6.4 DC Connection

### 6.4.1 Requirements for the DC Connection

#### **Requirements for the PV modules per input:**

- All PV modules must be of the same type.
- The same number of series-connected PV modules must be connected to all strings.
- All PV modules must be aligned identically.
- All PV modules must have the same tilt angle.
- The thresholds for the input voltage and the input current of the inverter must be adhered to (see Section 12 "Technical Data", page 61).
- On the coldest day based on statistical records, the open-circuit voltage of the PV array must never exceed the maximum input voltage of the inverter.

#### **Additionally required material (not included in the scope of delivery):**

- Depending on the number of strings, one or two conduits made of metal: 25.4 mm (1 in.)
- Depending on the number of conduits, one or two UL listed rain-tight conduit fittings for wet locations complying with UL514B: 25.4 mm (1 in.)
- For closing unused enclosure openings for the DC connection: UL-listed type 3R filler plugs

#### **Cable requirements:**

- The DC cables must be approved for temperatures of over +90°C (+194°F).
- The maximum cable length subject to conductor cross-section must be observed.
- Cable type: copper wire
- Use only solid wire or stranded wire.
- Conductor cross-section: 10 mm<sup>2</sup> to 35 mm<sup>2</sup> (8 AWG to 2 AWG)
- The DC cables must be sized in accordance with the installation requirements applicable on site.

## 6.4.2 Connecting the PV Array

### Requirements:

- A means of disconnecting the inverter from the PV array must be present.
- The grounding of the PV system must be executed as per the specifications of Paragraph 690.41 to 690.47 of the *National Electrical Code*® ANSI/NFPA 70 and is the responsibility of the installer.
- All electrical installations must be carried out in accordance with the local standards and the *National Electrical Code*® ANSI/NFPA 70 or the *Canadian Electrical Code*® CSA C22.1.

### Procedure:

1. **⚠ WARNING**

#### Danger to life due to electric shock

- Disconnect the inverter from the utility grid and ensure that it cannot be reconnected.
- Disconnect the inverter from the PV array and ensure that it cannot be reconnected.

2. If the lower enclosure lid is mounted, loosen all screws of the lower enclosure lid using an Allen key (AF 3) and lift the enclosure lid from below and remove it.

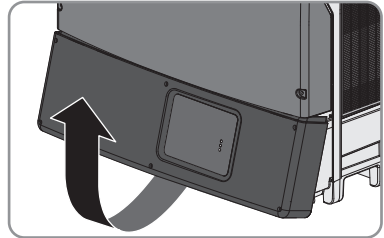

3. Release the screws of the DC protective cover using an Allen key (AF 3) and remove the DC protective cover.

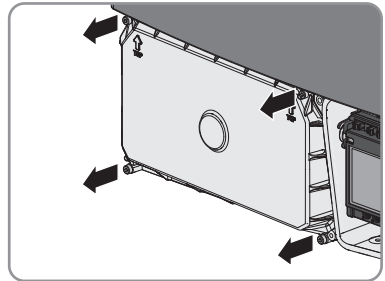

4. **NOTICE**

#### Damage to the inverter due to moisture and dust intrusion

Electronic components in the inverter can be destroyed or damaged as a result of dust or moisture intrusion. The enclosure openings are suitable for conduits of 25.4 mm (1 in.).

- Only use one opening per string.
- Do not enlarge the enclosure openings.

5. Remove the adhesive tape from both openings.
6. Insert one conduit fitting for each string into the opening and tighten from the inside using the counter nut.



7. Attach one conduit for each string to the opening.
8. Insert the DC cables through the conduit into the interior of the inverter.
9. Strip the insulation of the DC cables by 18 mm (0.71 in.).
10. For connecting the string to **INPUT A**, connect the DC cables to the connecting terminal plate for the DC connection:
  - Connect the positive DC cable to the red terminal **A+** and tighten with a screwdriver (torque: 5.8 Nm (51 lb-in.)).
  - Connect the negative DC cable to the black terminal **A-** and tighten with a screwdriver (torque: 5.8 Nm (51 lb-in.)).
11. For connecting the string to **INPUT B**, connect the DC cables to the connecting terminal plate for the DC connection:
  - Connect the positive DC cable to the red terminal **B+** and tighten with a screwdriver (torque: 5.8 Nm (51 lb-in.)).
  - Connect the negative DC cable to the black terminal **B-** and tighten with a screwdriver (torque: 5.8 Nm (51 lb-in.)).
12. Ensure that all DC cables are securely in place.
13. Close unused enclosure openings with UL-listed type 3R filler plugs.
14. In order to connect an additional grounding, additionally ground the enclosure (see Section 6.5, page 33).
15. If no additional grounding is to be connected, reattach the DC protective cover. Tighten all four screws with an Allen key (AF 3) in the order 1 to 4 (torque: 3.5 Nm (31 lb-in.)).

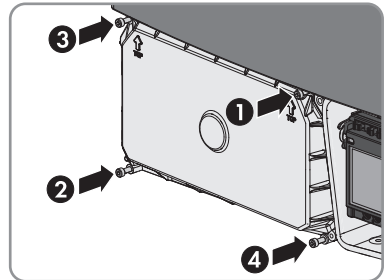

## 6.5 Additional Grounding of the Enclosure

The inverter is equipped with a grounding terminal with two connection points on the DC side for additional grounding (e.g. use of a grounding electrode).

The grounding terminal is yellow/green and identified as follows:

- Equipment grounding terminal: Symbol  $\oplus$
- Grounding electrode conductor: labeling **GEC**

### Cable requirements:

- The cable must be designed in accordance with the local installation requirements and for temperatures of over +90°C (+194°F).
- Cable type: copper wire
- Conductor cross-section: 10 mm<sup>2</sup> to 35 mm<sup>2</sup> (8 AWG to 2 AWG)

**Requirement:**

- The conduits must be correctly connected to the inverter.

**Procedure:**1. **⚠ DANGER****Danger to life due to electric shock**

- Disconnect the inverter from all voltage sources (see Section 9, page 40).
2. If the protective cover is mounted, loosen the screws of the DC protective cover using an Allen key (AF 3) and remove the DC protective cover.
  3. Lead the equipment grounding conductor or the cable of the grounding electrode through the installed conduit into the inside of the inverter.
  4. Strip the equipment grounding conductor or the cable of the grounding electrode 18 mm (0.71 in.).
  5. Connect the equipment grounding conductor to the connection point with the symbol  $\oplus$  and tighten with a screwdriver (blade width: 6 mm (0.24 in.)) (torque: 5.8 Nm (51 in-lb.)).
  6. Connect the grounding electrode cable to the connection point **GEC** and tighten with a screwdriver (blade width: 6 mm (0.24 in.)) (torque: 5.8 Nm (51 in-lb.)).
  7. Make sure the equipment grounding conductor or the grounding electrode cable is firmly in place.
  8. Reattach the DC protective cover. Tighten all four screws with an Allen key (AF 3) in the order 1 to 4 (torque: 3.5 Nm (31 lb-in.)).

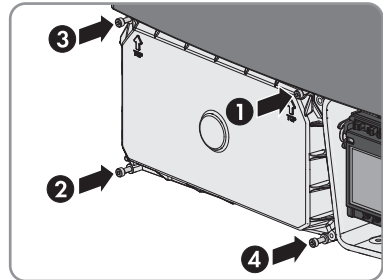

## 7 Commissioning

### Requirements:

- The circuit breaker must be correctly rated.
- A means of disconnecting the inverter from the PV array must be present.
- The inverter must be correctly mounted and closed.
- All cables must be correctly connected to the terminals.
- Unused openings for the DC connection in the inverter enclosure must be closed with UL-listed type 3R filler plugs.
- Unused openings for the Ethernet connection or the communication connection in the inverter enclosure must be sealed tightly. The factory-mounted filler plugs can be used for that purpose.

### Procedure:

1. Make sure that the AC cable is routed in such way that it cannot be damaged by the partition in the lower enclosure lid.
2. Insert the lower enclosure lid from above and fold it down. The screws must protrude from the lower enclosure lid.

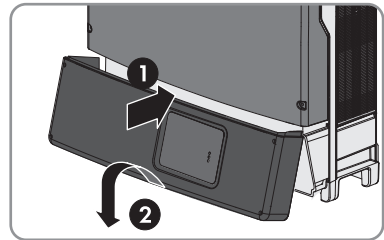

3. Tighten all six screws with an Allen key (AF 3) in the order 1 to 6 (torque: 2.0 Nm (17.7 lb-in.)).

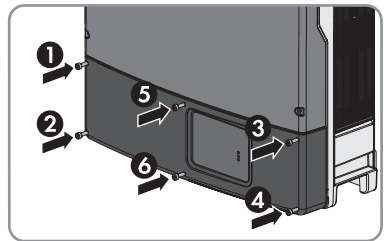

4. Switch on all DC disconnectors between the inverter and the PV array.
5. Switch on the circuit breaker and all AC disconnectors.
  - The green LED is glowing. Feed-in operation begins.
  - Green LED is flashing?
    - The DC input voltage is still too low.
      - Once the DC input voltage is sufficiently high, feed-in operation begins.
  - The red LED is glowing?
    - There is probably an error.
      - Rectify the error (see Section 10 "Troubleshooting", page 41).

## 8 Configuration

### 8.1 Connecting the Inverter to the Network

**Additionally required material (not included in the scope of delivery):**

- One network cable

**Cable requirements:**

- Type of cable: 100BaseTx, CAT5 with S-FTP or S-STP shielding  
SMA recommends the cable type "SMA COMCAB-OUT-xxx" for outdoors, and the cable type "SMA COMCAB-INxxx" for indoors. The cables are available in the lengths xxx = 100 m (328 ft.), 200 m (656 ft.), 500 m (1,640 ft.), 1,000 m (3,281 ft.).
- Cross-section: at least 2 x 2 x 0.22 mm<sup>2</sup> or at least 2 x 2 x 24 AWG
- Maximum cable length: 100 m (328 ft.)
- UV-resistant for outdoor use
- Type of plug: RJ45

**Procedure:**

1.  **DANGER**

**Danger to life due to electric shock**

- Disconnect the inverter from all voltage sources (see Section 9, page 40).
2. Connect one end of the network cable directly to the PC or the router.
  3. Connect the other end of the network cable to the inverter:
    - Remove the filler plugs from the network connection opening on the inverter.
    - Attach the conduit to the opening.
    - Lead the network cable through the conduit into the interior of the inverter.
    - Release the screw of the display far enough to allow the display to be flipped up.
    - Flip the display up until it snaps into place.
    - Insert the network cable into one of the network jacks of the Webconnect Data Module.
    - Flip the display down and fasten the display screw hand-tight.
  4. Commission the inverter (see Section 7, page 35).

### 8.2 Registering the Inverter in Sunny Portal

If you want to use the Webconnect function and monitor your system in Sunny Portal, you must register your inverter in Sunny Portal.

**Requirements:**

- The inverter must be connected to a router with an Internet connection and must be integrated in your network. If the router does not support DHCP, or if DHCP is deactivated, you can use the SMA Connection Assist to integrate the inverter into the network (see [www.SMA-Solar.com](http://www.SMA-Solar.com)).
- The Internet address, registration ID (RID) and identification key (PIC) for registration in Sunny Portal must be available (see the additional label on the inverter or the supplementary sheet with information on SMA Speedwire/Webconnect).

**Procedure:**

- Register the inverter in Sunny Portal (see the user manual of Webconnect systems in Sunny Portal).

## 8.3 Changing the PV System Time and PV System Password

To protect the inverter against unauthorized access and administer the PV system correctly, change the standard system password and the system time by means of Sunny Explorer (for further information refer to the manual or help of the Sunny Explorer).

**Requirements:**

- The PV system must be commissioned (see Section 7 "Commissioning", page 35).
- A computer with an Ethernet interface must be available.
- Sunny Explorer from software version 1.06 must be installed on the computer.
- The system must be registered in Sunny Explorer.

**Procedure:**

1. Access the Sunny Explorer user interface.
2. Change the standard password of the PV system. This will protect your PV system from unauthorized access.
3. Change the PV system time.

## 8.4 Changing Operating Parameters

By default, the inverter is set to a specific country data set. You can find the country data set to which the inverter has been set on the enclosed supplementary sheet with the default settings or on the type label. Each country data set contains various operating parameters, which can be individually set according to the respective country. You can change the parameters after commissioning with a communication product (e.g. Sunny Explorer) (information on operating parameters and country data sets can be found at [www.SMA-Solar.com](http://www.SMA-Solar.com)).

**Requirements:**

- A communication product corresponding to the type of communication used must be available.
- The changes to the grid-relevant operating parameters must be approved by the responsible grid operator.
- SMA Grid Guard code for changing grid-relevant parameters must be available (see the Certificate "Order Form for the SMA Grid Guard Code" at [www.SMA-Solar.com](http://www.SMA-Solar.com)).

**Procedure:**

1. Access the user interface of the communication product.
2. If required, enter the SMA Grid Guard code.
3. Select and set the desired parameter.
4. Save settings.

## 8.5 Activating and Setting SMA OptiTrac Global Peak

For partially shaded PV modules, you should activate SMA OptiTrac Global Peak and set the interval at which the inverter optimizes the MPP of the PV system.

The basic procedure for changing operating parameters is explained in another section (see Section 8.4, page 37).

**Procedure:**

1. Select the parameter **OptiTrac Global Peak switched on** or **MPPShdw.IsOn** and set to **On**.
  2. Select the parameter **Cycle time of the OptiTrac Global Peak algorithm** or **MPPShdw.CycTms** and set the required time interval. The ideal time interval is usually six minutes. This value should only be increased if the shading situation changes extremely slowly.
- The inverter optimizes the MPP of the PV system at the predetermined time interval.

## 8.6 Adjustable Parameters

You can change the following parameters for voltage and frequency monitoring with a communication product (e.g. Sunny Explorer) (also see user manual of the communication product at [www.SMA-Solar.com](http://www.SMA-Solar.com)).

Name	Value/range	Default value
<b>Voltage monitoring median maximum threshold</b> (Overvoltage/Fast)	277.0 V to 332.4 V	332.4 V
<b>Voltage monitoring lower maximum threshold</b> (Overvoltage/Slow)	277.0 V to 332.4 V	304.7 V
<b>Voltage monitoring upper minimum threshold</b> (Undervoltage/Slow)	138.5 V to 277.0 V	243.8 V
<b>Voltage monitoring of median minimum threshold</b> (Undervoltage/Fast)	138.5 V to 277.0 V	138.5 V
<b>Voltage monitoring median max. threshold trip.time</b> (Overvoltage/Fast, maximum time)	0.1 s to 6,000 s	0.16 s
<b>Voltage monitoring lower max. threshold trip. time</b> (Overvoltage/Slow, maximum time)	0.1 s to 6,000 s	1.0 s
<b>Voltage monitoring upper min. threshold trip. time</b> (Undervoltage/Slow, maximum time)	0.1 s to 1,000 s	2.0 s

Name	Value/range	Default value
<b>Voltage monitoring median min. threshold trip.time</b> (Undervoltage/Fast, maximum time)	0.1 s to 1,000 s	0.16 s
<b>Frequency monitoring lower maximum threshold</b> (Overfrequency)	50 Hz to 65 Hz	60.5 Hz
<b>Frequency monitoring upper minimum threshold</b> (Underfrequency)	44 Hz to 60 Hz	59.3 Hz
<b>Frq. monitoring lower max. threshold trip. time</b> (Overfrequency, maximum time)	0.1 s to 9,000 s	0.16 s
<b>Frq. monitoring upper min. threshold trip. time</b> (Underfrequency, maximum time)	0.1 s to 30,000 s	0.16 s

## 9 Disconnecting the Inverter from Voltage Sources

Prior to performing any work on the inverter, always disconnect it from all voltage sources as described in this section.

1. **⚠ DANGER**

**Danger to life due to electric shock**

- Disconnect the inverter from the utility grid and ensure that it cannot be reconnected.
- Disconnect the inverter from the PV array and ensure that it cannot be reconnected.

2. Wait five minutes until the LEDs on the inverter switch off.
3. Release all screws of the lower enclosure lid using an Allen key (AF 3).
4. Lift and remove the lower enclosure lid from below.

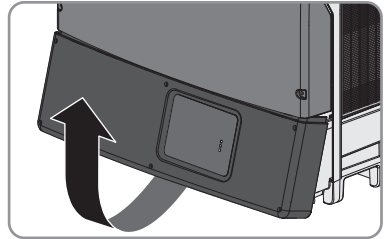

5. Release the screws of the DC protective cover using an Allen key (AF 3) and remove the DC protective cover.

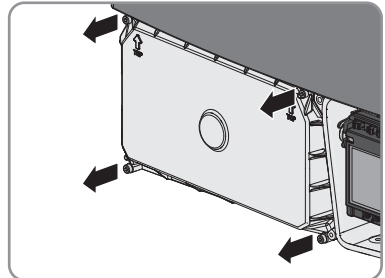

6. Use a suitable measuring device to ensure that no voltage is present at the DC terminals.
7. Use a suitable measuring device to ensure that no voltage is present at the AC terminals.



# 10 Troubleshooting

## 10.1 LED Signals

The LEDs indicate the operating state of the inverter.

Designation	Status	Explanation
Green LED	glowing	The inverter is in operation.
	flashing	The conditions for grid feed-in are not met. or The inverter has reduced its output power due to excessive temperature.
Red LED	glowing	An error has occurred. You will find the detailed error message in Sunny Portal or Sunny Explorer. You can find the error cause and its corrective measures in this document (see Section 10.2.2 "Warnings and Errors", page 43).
Blue LED	flashing	The parameter for finding other inverters is activated.
	off	No radio communication is active.

### **i** All LEDs are off

When all three LEDs are off, this means that the inverter is switched off as the DC input voltage on the inverter is too low for grid feed-in.

## 10.2 Event Messages

### 10.2.1 Information

You can configure the communication product to display the events that occur during operation. This type of event message is for information purposes only.

Event message	Cause
Set parameter	The inverter is setting the parameters.
Parameters set successfully	A new country data set has been configured.
Update file OK	The update file found is valid.
SD memory card is read	The inverter is currently reading the SD memory card.
No new update on the SD memory card	There are no update files relevant for this inverter on the SD memory card or the available update has already been carried out.
Update communication	The inverter is updating the communication component.
Update main CPU	The inverter is updating the inverter component.
Update RS485 module	The inverter is updating the 485 Data Module.

Event message	Cause
Webconnect update	The inverter is updating the Webconnect Data Module.
Update language table	The inverter is updating the language table.
Update completed	The inverter has successfully completed the update.
AFCI self-test successful	The inverter has successfully performed the arc fault detection self-test.
Grid parameter unchanged	Changing the grid parameters is not possible.
Installer code valid	The SMA Grid Guard code entered is valid. Protected parameters have now been unlocked and you can adjust the parameters. The parameters will be automatically locked again after ten feed-in hours.
Self-test	The self-test is being carried out.

## 10.2.2 Warnings and Errors

The communication product (e.g. Sunny Explorer) displays the warnings and errors that apply to the inverter, the utility grid or the PV array. The warning or error is identified by an event number and the corresponding message.

Event number	Message, cause and corrective measures
101 to 103	<p data-bbox="288 323 392 352"><b>Grid fault</b></p> <p data-bbox="288 360 1002 416">The grid voltage or grid impedance at the connection point of the inverter is too high. The inverter has disconnected from the utility grid.</p> <p data-bbox="288 424 508 453"><b>Corrective measures:</b></p> <ul data-bbox="311 461 1002 517" style="list-style-type: none"> <li data-bbox="311 461 1002 517">• Check whether the grid voltage at the connection point of the inverter is permanently in the permissible range.</li> </ul> <p data-bbox="333 525 1002 636">If the grid voltage is outside the permissible range due to local grid conditions, contact the grid operator. The grid operator must agree with an adjustment of the voltage at the feed-in point or with a change of the monitored operating limits.</p> <p data-bbox="333 644 1002 699">If the grid voltage is permanently within the permissible range and this message is still displayed, contact the SMA Service Line.</p>
202 to 203	<p data-bbox="288 707 392 735"><b>Grid fault</b></p> <p data-bbox="288 743 1002 831">The utility grid has been disconnected, the AC cable is damaged or the grid voltage at the connection point of the inverter is too low. The inverter has disconnected from the utility grid.</p> <p data-bbox="288 839 508 868"><b>Corrective measures:</b></p> <ol data-bbox="311 876 1002 1035" style="list-style-type: none"> <li data-bbox="311 876 1002 904">1. Make sure that the circuit breaker is switched on.</li> <li data-bbox="311 912 1002 941">2. Make sure that the AC cable is not damaged.</li> <li data-bbox="311 949 1002 978">3. Make sure that the AC cable is correctly connected.</li> <li data-bbox="311 986 1002 1035">4. Check whether the grid voltage at the connection point of the inverter is permanently in the permissible range.</li> </ol> <p data-bbox="333 1043 1002 1155">If the grid voltage is outside the permissible range due to local grid conditions, contact the grid operator. The grid operator must agree with an adjustment of the voltage at the feed-in point or with a change of the monitored operating limits.</p> <p data-bbox="333 1163 1002 1219">If the grid voltage is permanently within the permissible range and this message is still displayed, contact the SMA Service Line.</p>

Event number	Message, cause and corrective measures
301	<p><b>Grid fault</b></p> <p>The ten-minute average value of the grid voltage is no longer within the permissible range. The grid voltage or grid impedance at the connection point is too high. The inverter disconnects from the utility grid to comply with the power quality.</p> <p><b>Corrective measures:</b></p> <ul style="list-style-type: none"> <li>• Check whether the grid voltage at the connection point of the inverter is permanently in the permissible range. If the grid voltage is outside the permissible range due to local grid conditions, contact the grid operator. The grid operator must agree with an adjustment of the voltage at the feed-in point or with a change of the monitored operating limits. If the grid voltage is permanently within the permissible range and this message is still displayed, contact the SMA Service Line.</li> </ul>
401	<p><b>Grid fault</b></p> <p>The inverter is no longer in grid-parallel operation. The inverter has stopped feeding into the utility grid.</p> <p><b>Corrective measures:</b></p> <ul style="list-style-type: none"> <li>• Check the grid connection for significant, short-term frequency fluctuations.</li> </ul>
404	<p><b>Grid fault</b></p> <p>The inverter is no longer in grid-parallel operation. The inverter has stopped feeding into the utility grid.</p> <p><b>Corrective measures:</b></p> <ul style="list-style-type: none"> <li>• Check the grid connection for significant, short-term frequency fluctuations.</li> </ul>
501	<p><b>Grid fault</b></p> <p>The power frequency is not within the permissible range. The inverter has disconnected from the utility grid.</p> <p><b>Corrective measures:</b></p> <ul style="list-style-type: none"> <li>• If possible, check the power frequency and observe how often fluctuations occur. If fluctuations occur frequently and this message is displayed often, contact the grid operator. The grid operator must approve changes to the operating parameters of the inverter. If the grid operator gives his approval, discuss any changes to the operating parameters with the SMA Service Line.</li> </ul>

Event number	Message, cause and corrective measures
601	<p><b>Grid fault</b></p> <p>The inverter has detected an excessively high proportion of direct current in the grid current.</p> <p><b>Corrective measures:</b></p> <ol style="list-style-type: none"> <li>1. Check the grid connection for direct current.</li> <li>2. If this message is displayed frequently, contact the grid operator and check whether the monitoring threshold on the inverter can be raised.</li> </ol>
701	<p><b>Frequency not permitted &gt; Check parameter</b></p> <p>The power frequency is not within the permissible range. The inverter has disconnected from the utility grid.</p> <p><b>Corrective measures:</b></p> <ul style="list-style-type: none"> <li>• If possible, check the power frequency and observe how often fluctuations occur.</li> </ul> <p>If fluctuations occur frequently and this message is displayed often, contact the grid operator. The grid operator must approve changes to the operating parameters of the inverter.</p> <p>If the grid operator gives his approval, discuss any changes to the operating parameters with the SMA Service Line.</p>
1302	<p><b>Waiting for grid voltage &gt; Installation failure grid connection &gt; Check grid and fuses</b></p> <p>The inverter has detected an error in the AC cabling. The inverter cannot connect to the utility grid.</p> <p><b>Corrective measures:</b></p> <ol style="list-style-type: none"> <li>1. Ensure that the AC connection is correct (see Section 6.3 "AC Connection", page 28).</li> <li>2. Ensure that the country data set has been configured correctly. Select the parameter <b>Set country standard</b> or <b>CntrySet</b> and check value.</li> </ol>
1501	<p><b>Reconnection fault grid</b></p> <p>The changed country data set or the value of a parameter you have set does not correspond to the local requirements. The inverter cannot connect to the utility grid.</p> <p><b>Corrective measures:</b></p> <ul style="list-style-type: none"> <li>• Ensure that the country data set has been configured correctly. Select the parameter <b>Set country standard</b> or <b>CntrySet</b> and check value.</li> </ul>

Event number	Message, cause and corrective measures
3301	<p><b>Unstable operation &gt; Generator output too low</b></p> <p>There is not enough power at the DC input of the inverter for stable operation. This may be caused by snow on the PV modules or insufficient irradiation. The inverter interrupts the feed-in operation and cannot connect to the utility grid.</p> <p><b>Corrective measures:</b></p> <ol style="list-style-type: none"> <li>1. Wait for higher irradiation.</li> <li>2. If this message is displayed frequently, ensure that the PV array has been correctly rated and wired.</li> </ol>
3302	<p><b>Unstable operation &gt; Abort self-test</b></p> <p>There is not enough power at the DC input of the inverter for stable operation. This may be caused by snow on the PV modules or insufficient irradiation. The inverter interrupts the feed-in operation and cannot connect to the utility grid.</p> <p><b>Corrective measures:</b></p> <ol style="list-style-type: none"> <li>1. If irradiation is too low, wait for it to increase.</li> <li>2. If this message is displayed frequently, ensure that the PV array has been correctly rated and wired.</li> </ol>
3303	<p><b>Unstable operation &gt; Data storage blocked</b></p> <p>There is not enough power at the DC input of the inverter for stable operation. This may be caused by snow on the PV modules or insufficient irradiation. The inverter interrupts the feed-in operation and cannot connect to the utility grid.</p> <p><b>Corrective measures:</b></p> <ol style="list-style-type: none"> <li>1. Wait for higher irradiation.</li> <li>2. If this message is displayed frequently, ensure that the PV array has been correctly rated and wired.</li> </ol>
3401 to 3402	<p><b>DC overvoltage &gt; Disconnect generator</b></p> <p>Overvoltage at DC input. This can destroy the inverter.</p> <p><b>Corrective measures:</b></p> <ol style="list-style-type: none"> <li>1. <b>IMMEDIATELY DISCONNECT</b> the inverter from all voltage sources (see Section 9, page 40).</li> <li>2. Check whether the DC voltage is below the maximum input voltage of the inverter. <p>If the DC voltage is below the maximum input voltage of the inverter, reconnect the DC connectors to the inverter.</p> <p>If the DC voltage is above the maximum input voltage of the inverter, ensure that the PV array has been correctly rated or contact the installer of the PV array.</p> </li> <li>3. If this message is repeated frequently, contact the SMA Service Line.</li> </ol>

Event number	Message, cause and corrective measures
3501	<p><b>Insulation resistance &gt; Check generator</b></p> <p>The inverter has detected a ground fault in the PV array.</p> <p><b>Corrective measures:</b></p> <ul style="list-style-type: none"> <li>• Check the PV system for ground faults (see Section 10.6, page 53).</li> </ul>
3601	<p><b>High discharge current &gt; Check generator</b></p> <p>The leakage currents of the inverter and the PV array are too high. There is a ground fault, a residual current or a malfunction.</p> <p>The inverter interrupts feed-in operation immediately after exceeding a threshold and then automatically reconnects to the utility grid. If this process happens five times a day, the inverter disconnects from the utility grid and terminates feed-in.</p> <p><b>Corrective measures:</b></p> <ul style="list-style-type: none"> <li>• Check the PV system for ground faults (see Section 10.6, page 53).</li> </ul>
3701	<p><b>Residual current too high &gt; Check generator</b></p> <p>The inverter has detected a residual current due to temporary grounding of the PV array.</p> <p><b>Corrective measures:</b></p> <ul style="list-style-type: none"> <li>• Check the PV system for ground faults (see Section 10.6, page 53).</li> </ul>
3801 to 3802	<p><b>DC overcurrent &gt; Check generator</b></p> <p>Overcurrent at the DC input. The inverter briefly interrupts feed-in operation.</p> <p><b>Corrective measures:</b></p> <ul style="list-style-type: none"> <li>• If this message is displayed frequently, ensure that the PV array has been correctly rated and wired.</li> </ul>
3901 to 3902	<p><b>Waiting for DC start conditions &gt; Start conditions not met</b></p> <p>The feed-in conditions for the utility grid are not yet fulfilled.</p> <p><b>Corrective measures:</b></p> <ol style="list-style-type: none"> <li>1. Wait for higher irradiation.</li> <li>2. If this message is displayed frequently in the morning, increase the voltage limit for starting grid feed-in. Change the parameter <b>Minimum voltage input</b> or <b>A.VStr, B.VStr</b>.</li> <li>3. If this message is displayed frequently with medium irradiation, ensure that the PV array is correctly rated.</li> </ol>
4301	<p><b>Serial el.arc in String detected by AFCI mod.</b></p> <p>The inverter has detected an electric arc. The inverter interrupts grid feed-in and cannot connect to the utility grid.</p> <p><b>Corrective measures:</b></p> <ul style="list-style-type: none"> <li>• Reset the operation inhibition (see Section 10.7, page 54).</li> </ul>

Event number	Message, cause and corrective measures
6001 to 6438	<p><b>Self diagnosis &gt; Interference of device</b></p> <p>The cause must be determined by the SMA Service Line.</p> <p><b>Corrective measures:</b></p> <ul style="list-style-type: none"> <li>• Contact the SMA Service Line.</li> </ul>
6501 to 6511	<p><b>Self diagnosis &gt; Interference of device</b></p> <p>The inverter has switched off due to excessive temperature.</p> <p><b>Corrective measures:</b></p> <ol style="list-style-type: none"> <li>1. Clean the fans (see Section 10.4, page 49).</li> <li>2. Ensure that the inverter has sufficient ventilation.</li> </ol>
6512	<p><b>Minimum operating temperature not reached</b></p> <p>The inverter will only recommence grid feed-in once the temperature has reached at least <math>-25^{\circ}\text{C}</math> (<math>-13^{\circ}\text{F}</math>).</p>
6603 to 6604	<p><b>Self diagnosis &gt; Overload</b></p> <p>The cause must be determined by the SMA Service Line.</p> <p><b>Corrective measures:</b></p> <ul style="list-style-type: none"> <li>• Contact the SMA Service Line.</li> </ul>
6606	<p><b>Interference of device</b></p> <p>The cause must be determined by the SMA Service Line.</p> <p><b>Corrective measures:</b></p> <ul style="list-style-type: none"> <li>• Contact the SMA Service Line.</li> </ul>
6801 to 6802	<p><b>Self diagnosis &gt; Input A defective</b></p> <p>The cause must be determined by the SMA Service Line.</p> <p><b>Corrective measures:</b></p> <ul style="list-style-type: none"> <li>• Contact the SMA Service Line.</li> </ul>
6901 to 6902	<p><b>Self diagnosis &gt; Input B defective</b></p> <p>The cause must be determined by the SMA Service Line.</p> <p><b>Corrective measures:</b></p> <ul style="list-style-type: none"> <li>• Contact the SMA Service Line.</li> </ul>
7001 to 7002	<p><b>Sensor fault fan permanently on</b></p> <p>The cause must be determined by the SMA Service Line.</p> <p><b>Corrective measures:</b></p> <ul style="list-style-type: none"> <li>• Contact the SMA Service Line.</li> </ul>
7701 to 7703	<p><b>Self diagnosis &gt; Interference of device</b></p> <p>The cause must be determined by the SMA Service Line.</p> <p><b>Corrective measures:</b></p> <ul style="list-style-type: none"> <li>• Contact the SMA Service Line.</li> </ul>



Event number	Message, cause and corrective measures
9002	<p><b>Installer code invalid</b></p> <p>The SMA Grid Guard code entered is incorrect. The operating parameters are still protected and cannot be changed.</p> <p><b>Corrective measures:</b></p> <ul style="list-style-type: none"> <li>• Enter the correct SMA Grid Guard code.</li> </ul>
9003	<p><b>Grid parameter locked</b></p> <p>The parameters are now locked. You cannot change the parameters.</p> <p><b>Corrective measures:</b></p> <ul style="list-style-type: none"> <li>• Unlock the parameters with the SMA Grid Guard code.</li> </ul>

## 10.3 Cleaning the Inverter

### NOTICE

#### Damage to the inverter due to the use of cleaning agents

- If the inverter is dirty, clean the enclosure lid and the LEDs using clean water and a cloth only.

## 10.4 Cleaning the Fans

### 10.4.1 Cleaning the Fan at the Bottom

First clean the fan at the bottom of the inverter according to the following procedure, and then clean the fan on the left-hand side of the enclosure.

#### 1. **⚠ DANGER**

##### Danger to life due to electric shock

Disconnect the inverter from all voltage sources (see Section 9, page 40).

2. Wait for the fan to stop rotating.
3. Remove the fan guard and clean it:
  - Use a screwdriver to push the two locking tabs at the right-hand edge of the fan guard to the right-hand side and remove them from the retainer.
  - Carefully remove the fan guard.
  - Clean the fan guard with a soft brush, a paint brush, a cloth or compressed air.

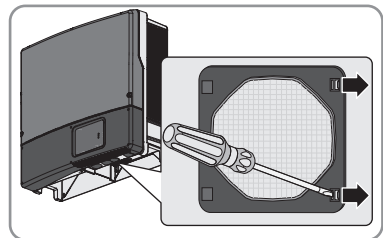

4. Push the locking tabs of the fan towards the center.

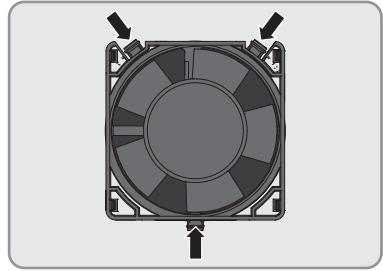

5. Carefully remove the fan from the inverter.
6. Release and remove the fan plug.

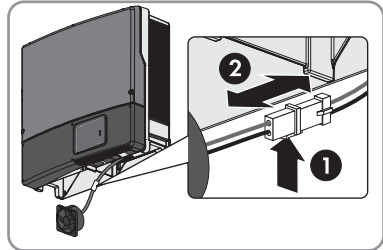

7. **NOTICE**

**Damage to the fan due to compressed air**

- Clean the fan with a soft brush, a paint brush, or a damp cloth only.

8. Insert the plug of the fan in the pin connector until it snaps into place.

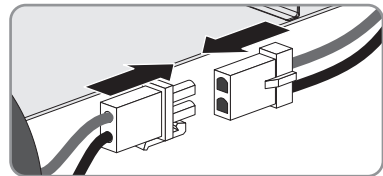

9. Insert the fan in the inverter until it snaps into place.
10. Push the fan guard into the retainer until it snaps into place.
11. Clean the fan on the left-hand side of the enclosure (see Section 10.4.2, page 50).

## 10.4.2 Cleaning the Fan on the Left-Hand Side of the Enclosure

1. Ensure that the inverter is disconnected from all voltage sources (see Section 9, page 40).
2. Remove the ventilation grids on the left-hand and right-hand sides and clean them:

- Turn the rotary fastener of the ventilation grid with a flat-blade screwdriver until the notch is in a vertical position.

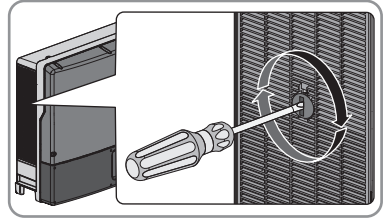

- Remove the ventilation grid. Use a screwdriver to gently lever open the ventilation grid.

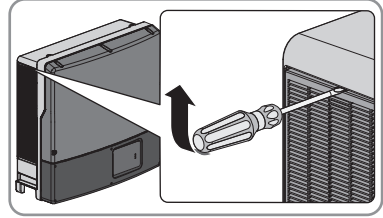

- Clean the ventilation grid with a soft brush, a paint brush, or compressed air.

3. **NOTICE**

**Damage to the inverter due to foreign bodies**

- Do not remove the ventilation grids permanently, otherwise foreign bodies could penetrate the enclosure.

4. Wait for the fan to stop rotating.
5. Push the locking tabs of the fan towards the center.

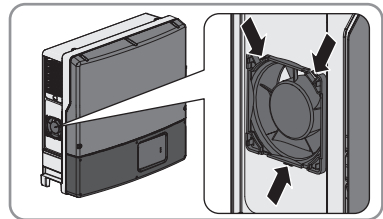

6. Carefully remove the fan from the inverter.
7. Release and remove the fan plug.

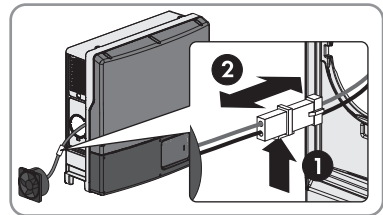

8. **NOTICE**

**Damage to the fan due to compressed air**

- Clean the fan with a soft brush, a paint brush, or a damp cloth only.

9. Insert the plug of the fan in the pin connector until it snaps into place.

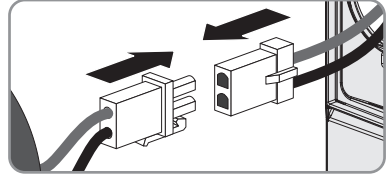

10. Insert the fan in the inverter until it snaps into place.
11. Attach the ventilation grids on the right-hand and left-hand side of the inverter:
- Reinsert the ventilation grid until it snaps into place.

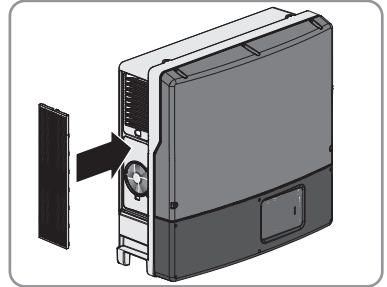

- Turn the rotary lock of the ventilation grid with a flat-blade screwdriver until the slot is in a horizontal position and the arrows point to the right.

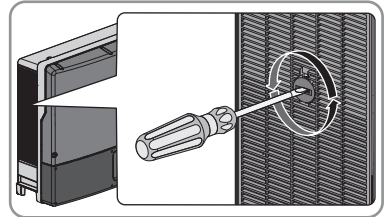

- Ensure that the ventilation grid is securely in place.

12. Commission the inverter (see Section 7 "Commissioning", page 35).
13. Check that the fan is working properly (see Section 10.5, page 52).

## 10.5 Checking the Fans

You can check the function of the fans by setting a parameter.

### Requirements:

- A communication product corresponding to the type of communication used must be available.
- The inverter must be in operation.

### Procedure:

1. Access the user interface of the communication product and log in as installer.
2. Select the parameter **Fan test** or **FanTst** and set to **On**.
3. Save settings.

4. Check whether air is coming out of the ventilation grids and whether the fans are making any unusual noises.

If there is no air coming out of the ventilation grids or the fans are making unusual noises, presumably the fans were not installed properly. Check the installation of the fans.

If the fans were installed correctly, contact the SMA Service Line.

5. Select the parameter **Fan test** or **FanTst** and set to **Off**.
6. Save settings.

## 10.6 Checking the PV System for Ground Faults

If the red LED is glowing and the message **Insulation resistance > Check generator** is displayed in the communication product (e.g. Sunny Portal), this could indicate a ground fault. The electrical insulation from the PV system to ground is defective or insufficient.

### **⚠ WARNING**

#### **Danger to life due to electric shock**

In the event of a ground fault, high voltages can be present.

- Touch the cables of the PV array on the insulation only.
- Do not touch any parts of the sub-structure or frame of the PV array.
- Do not connect PV strings with ground faults to the inverter.

### **NOTICE**

#### **Destruction of the measuring device due to overvoltage**

- Only use measuring devices with a DC input voltage range up to 1,000 V.

Proceed as follows to check each string in the PV system for ground faults.

#### **Procedure:**

1. **⚠ DANGER**

#### **Danger to life due to electric shock**

- Disconnect the inverter from all voltage sources (see Section 9, page 40).

2. Measure the voltages at the DC terminal:

- Measure the voltages between the positive terminal and the ground potential.
- Measure the voltages between the negative terminal and the ground potential.
- Measure the voltages between the positive and negative terminals.

If the following results are present at the same time, there is a ground fault in the PV system:

- All measured voltages are stable.
  - The sum of the two voltages to ground potential is approximately equal to the voltage between the positive and negative terminals.
- Determine the location of the ground fault via the ratio of the two measured voltages.

- Eliminate the ground fault.

If there is no ground fault and the message is still displayed, contact the SMA Service Line.

### Location of the ground fault

The example shows a ground fault between the second and third PV module.

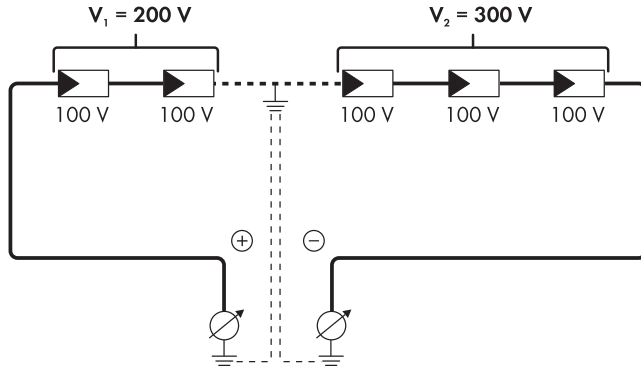

3. Reattach the DC protective cover. Tighten all four screws with an Allen key (AF 3) in the order 1 to 4 (torque: 3.5 Nm (31 lb-in.)).

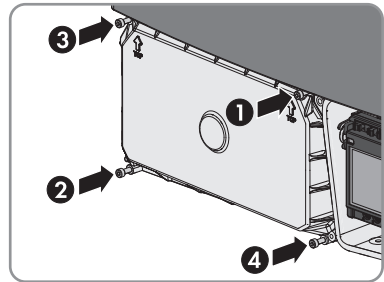

4. Commission the inverter (see Section 7 "Commissioning", page 35).

## 10.7 Resetting the Operation Inhibition after Detection of an Arc Fault

If the red LED is glowing and the message **Serial el.arc in String detected by AFCI mod.** is displayed in the communication product (e.g. Sunny Portal), the inverter has detected an electric arc and interrupts feed-in operation.

### Requirement:

- A communication product corresponding to the type of communication used must be available.

There are two options for resetting the operation inhibition. Proceed as follows.

**Procedure:**

1.

**⚠ DANGER****Danger to life due to electric shock**

- Disconnect the inverter from all voltage sources (see Section 9, page 40).
2. Check whether the PV modules, the connected cables or plugs are defective.  
Repair or replace defective PV modules, cables or plugs.
  3. Recommission the inverter (see Section 7 "Commissioning", page 35).
  4. Access the user interface of the communication product.
  5. Reset the operation inhibition by setting one of the following parameters:
    - Select the parameter **Reset operating data** or **Op.FncSetIstl** and set to **Reset operation inhibition** or **RSPermStopOp**. This effects resetting of the operation inhibition and the inverter will start feeding in again.
    - or**
    - Select the parameter **AFCI switched on** or **AfcilsOn** and set to **No** and then back to **Yes**. This effects resetting of the operation inhibition and the inverter will start feeding in again.

## 10.8 Procedure for Receiving a Replacement Device

Under fault conditions, your inverter may need to be replaced. If this is the case, you will receive a replacement device fitted with two transport lids. Prior to returning your inverter to SMA, you must replace the upper and lower enclosure lids of your inverter with the corresponding transport lids.

**NOTICE****Damage to the seal of the enclosure lid in sub-zero conditions**

When opening the Sunny Tripower during frost, the seal of the enclosure lid can be damaged. There may be an ingress of moisture damaging the Sunny Tripower.

- Do not open the inverter when the ambient temperature is below  $-5\text{ °C}$  ( $23\text{ °F}$ ).  
If a layer of ice has formed on the seal of the lid in sub-zero conditions, remove it prior to opening the inverter (e.g. by melting the ice with warm air). Observe the applicable safety regulations.

**NOTICE****Damage to the inverter due to moisture and dust intrusion**

Dust or moisture intrusion can damage the inverter and impair its functionality.

- Never open the inverter when it is raining or snowing, or the humidity is over 95%.

**NOTICE****Electrostatic discharge**

Touching electronic components can cause damage to or destroy the inverter through electrostatic discharge.

- Ground yourself before touching any component.

**Procedure:**1. **⚠ DANGER****Danger to life due to electric shock**

- Decommission your inverter (see Section 11, page 59).
2. Remove all screws of the upper enclosure lid of your inverter using an Allen key (AF 4).
  3. Pull the upper enclosure lid of your inverter forward and off.
  4. Release all screws of the lower transport lid using an Allen key (AF 3).
  5. Lift the lower transport lid upwards from below and remove it.

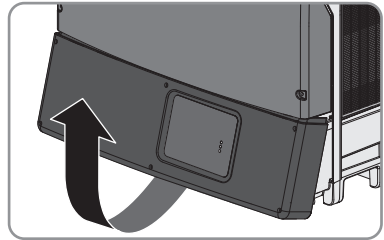

6. Remove all screws of the upper transport lid using an Allen key (AF 4).
7. Pull the upper transport lid forward to remove it.
8. Prescrew the upper transport lid to your inverter using the six screws of the upper enclosure lid of the inverter and the corresponding conical spring washers, and then tighten them in the sequence 1 to 6 (torque: 6.0 Nm (53 in-lb.)). The grooved side of the conical spring washer must point to the screw head.

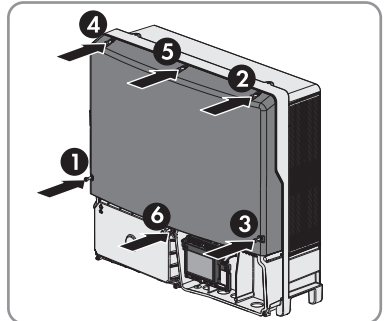

- The teeth of the conical spring washers press into the upper enclosure lid. This ensures that the upper enclosure lid is grounded.



9. Place the lower transport lid from the replacement device in position on your inverter and flip it down. The screws must protrude from the lower transport lid.

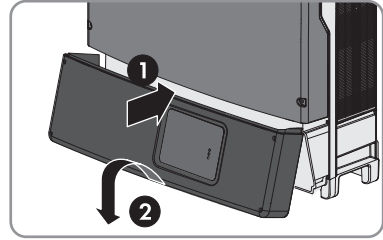

10. Tighten all six screws of the lower transport lid with an Allen key (AF 3) in the order 1 to 6 (torque: 2.0 Nm (17.7 in-lb.)).

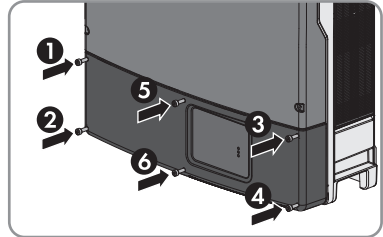

11. Prescrew the upper enclosure lid of your inverter onto the replacement device using the six screws and the corresponding conical spring washers, and then tighten them in the sequence 1 to 6 (torque: 6.0 Nm (53 in-lb.)). The grooved side of the conical spring washer must point to the screw head.

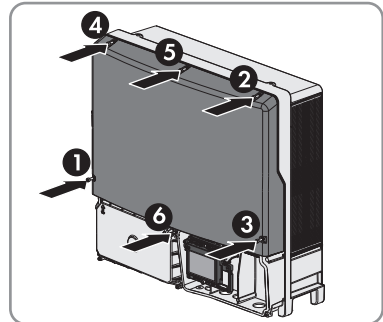

- The teeth of the conical spring washers press into the upper enclosure lid. This ensures that the upper enclosure lid is grounded.

12. Place the lower enclosure lid from your inverter in position on the replacement device and flip it down. The screws must protrude from the lower enclosure lid.

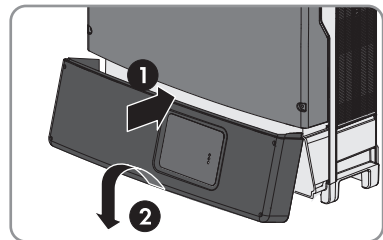

13. Tighten all six screws of the lower enclosure lid with an Allen key (AF 3) in the order 1 to 6 (torque: 2.0 Nm (17.7 in-lb.)).

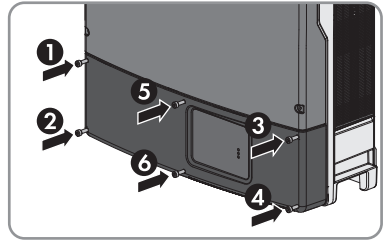

14. Mount, (see Section 5, page 19) connect (see Section 6, page 25) and commission the replacement device (see Section 7, page 35).

# 11 Decommissioning the Inverter

## ⚠ CAUTION

### Risk of injury when lifting the inverter, or if it is dropped

The inverter is heavy (see Section 12 "Technical Data", page 61). There is risk of injury if the inverter is lifted incorrectly or dropped while being transported or when attaching it to or removing it from the wall mounting bracket.

- Carry and lift the inverter upright with several people without tilting it. With one hand grasp the recessed grip, and with the other hand support the top part of the enclosure. This will prevent the inverter tipping forward.
- If the inverter is to be transported and lifted with a crane, remove the filler plugs on the top of the inverter and screw the eye bolts into the threads.

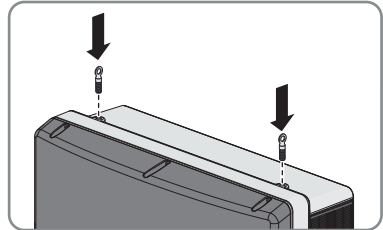
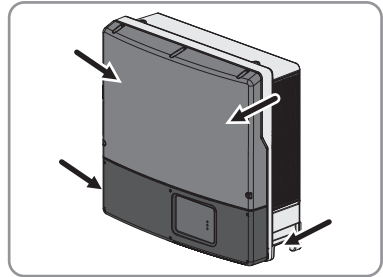

### Procedure:

#### 1. ⚠ DANGER

#### Danger to life due to electric shock

- Disconnect the inverter from all voltage sources (see Section 9, page 40).
2. Disconnect the DC cables from the connecting terminal plate for the DC connection using a screwdriver.
  3. Open all locking levers of the connecting terminal plate for the AC connection all the way, and pull out all conductors from the terminals.
  4. Remove all connected grounding cables from the grounding terminal.
  5. Remove all connected data cables.
  6. Remove all conduits with cables from the inverter.
  7. Close all enclosure openings.

**8.  CAUTION****Risk of burns due to hot enclosure parts**

- Wait 30 minutes before disassembling the inverter. This will allow the enclosure to cool down and thus prevent burn injuries.
9. Remove the inverter by lifting it vertically up and off the wall mounting bracket.
  10. Release the screws from the wall mounting bracket and take the bracket off the wall.
  11. If the inverter is to be stored or shipped in packaging, pack the inverter and the wall mounting bracket. Use the original packaging or packaging that is suitable for the weight and dimensions of the inverter and secure with tension belts if necessary.
  12. Dispose of the inverter in accordance with the locally applicable disposal regulations for electronic waste.

## 12 Technical Data

### 12.1 DC/AC

#### 12.1.1 Sunny Tripower 12000TL-US / 15000TL-US

##### DC Input

	STP 12000TL-US-10	STP 15000TL-US-10
Maximum DC power at $\cos \varphi = 1$	12,250 W	15,300 W
Maximum input voltage	1,000 V	1,000 V
MPP voltage range	300 V to 800 V	300 V to 800 V
Rated input voltage	675 V	675 V
Minimum input voltage	150 V	150 V
Initial input voltage	188 V	188 V
Maximum input current input A	33 A	33 A
Maximum input current input B	33 A	33 A
Maximum short-circuit current per string	43 A	43 A
Maximum residual input current	1,187 A <sub>pk</sub>	1,187 A <sub>pk</sub>
Duration of the maximum residual input current	0.0072 s	0.0072 s
Number of independent MPP inputs	2	2
Strings per MPP input	1	1

##### AC Output

	STP 12000TL-US-10	STP 15000TL-US-10
Rated power at 277 V, 60 Hz	12,000 W	15,000 W
Maximum apparent AC power	12,000 VA	15,000 VA
Rated grid voltage	480 / 277 WYE	480 / 277 WYE
AC voltage range	243.7 V to 304.7 V	243.7 V to 304.7 V
Nominal AC current at 277 V	14.5 A	18.1 A
Maximum output current	14.5 A	18.1 A
Total harmonic distortion of the output current with total harmonic distortion of the AC voltage < 2%, and AC power > 50% of the rated power	≤ 3%	≤ 3%
Maximum residual output current	142.5 A <sub>pk</sub>	142.5 A <sub>pk</sub>
Duration of the maximum residual output current	0.0131 s	0.0131 s

	STP 12000TL-US-10	STP 15000TL-US-10
Line synchronization characteristics / In-rush current	Method 2	Method 2
Rated power frequency	60 Hz	60 Hz
Operating range at AC power frequency 60 Hz	59.3 Hz to 60.5 Hz	59.3 Hz to 60.5 Hz
Maximum utility backfeed current to utility	-	-
Limits of accuracy of voltage measurement	2%	2%
Limits of accuracy of frequency measurement	$\pm 0.1$ Hz	$\pm 0.1$ Hz
Limits of accuracy of time measurement at nominal trip time	$\pm 0.1\%$	$\pm 0.1\%$
Output power at +60 °C (+140 °F)	12,000 W	15,000 W
Maximum power operating ambient temperature	+45 °C (+113 °F)	+45 °C (+113 °F)
Power factor at rated power	1	1
Feed-in phases	3	3
Connection phases	3	3
Overvoltage category in accordance with UL1741	IV	IV

## Efficiency

	STP 12000TL-US-10	STP 15000TL-US-10
Maximum efficiency, $\eta_{\max}$	98.2%	98.2%
CEC efficiency, $\eta_{\text{CEC}}$	97.5%	97.5%

## 12.1.2 Sunny Tripower 20000TL-US / 24000TL-US

### DC Input

	STP 20000TL-US-10	STP 24000TL-US-10
Maximum DC power at $\cos \varphi = 1$	20,400 W	24,500 W
Maximum input voltage	1,000 V	1,000 V
MPP voltage range	380 V to 800 V	450 V to 800 V
Rated input voltage	695 V	712 V
Minimum input voltage	150 V	150 V
Initial input voltage	188 V	188 V
Maximum input current input A	33 A	33 A

	STP 20000TL-US-10	STP 24000TL-US-10
Maximum input current input B	33 A	33 A
Maximum short-circuit current per string	43 A	43 A
Maximum residual input current	1,187 A <sub>pk</sub>	1,187 A <sub>pk</sub>
Duration of the maximum residual input current	0.0072 s	0.0072 s
Number of independent MPP inputs	2	2
Strings per MPP input	1	1

## AC Output

	STP 20000TL-US-10	STP 24000TL-US-10
Rated power at 277 V, 60 Hz	20,000 W	24,000 W
Maximum apparent AC power	20,000 VA	24,000 VA
Rated grid voltage	480 V / 277 V WYE	480 V / 277 V WYE
AC voltage range	243.7 V to 304.7 V	243.7 V to 304.7 V
Nominal AC current at 277 V	24.1 A	29 A
Maximum output current	24.1 A	29 A
Total harmonic distortion of the output current with total harmonic distortion of the AC voltage < 2%, and AC power > 50% of the rated power	≤ 3%	≤ 3%
Maximum residual output current	142.5 A <sub>pk</sub>	142.5 A <sub>pk</sub>
Duration of the maximum residual output current	0.0131 s	0.0131 s
Line synchronization characteristics / In-rush current	Method 2	Method 2
Rated power frequency	60 Hz	60 Hz
Operating range at AC power frequency 60 Hz	59.3 Hz to 60.5 Hz	59.3 Hz to 60.5 Hz
Maximum utility backfeed current to utility	-	-
Limits of accuracy of voltage measurement	2%	2%
Limits of accuracy of frequency measurement	±0.1 Hz	±0.1 Hz
Limits of accuracy of time measurement at nominal trip time	±0.1%	±0.1%
Output power at +60°C (+140°F)	17,000 W	17,000 W
Maximum power operating ambient temperature	+45°C (+113°F)	+45°C (+113°F)
Power factor at rated power	1	1

	STP 20000TL-US-10	STP 24000TL-US-10
Feed-in phases	3	3
Connection phases	3	3
Oversoltage category in accordance with UL1741	IV	IV

## Efficiency

	STP 20000TL-US-10	STP 24000TL-US-10
Maximum efficiency, $\eta_{\max}$	98.5%	98.5%
CEC efficiency, $\eta_{\text{CEC}}$	97.5%	98.0%

## 12.2 General Data

Width x height x depth	665 mm x 650 mm x 265 mm (26.18 in. x 25.59 in. x 10.43 in.)
Weight	60 kg (133 lbs)
Length x width x height of the packaging	780 mm x 380 mm x 790 mm (30.71 in. x 14.96 in. x 31.10 in.)
Transport weight	60 kg (133 lbs)
Operating temperature range	-25°C to +60°C (-13°F to +140°F)
Storage temperature	-40°C to +60°C (-40°F to +140°F)
Maximum permissible value for relative humidity, non-condensing	100%
Maximum operating altitude above mean sea level	2,000 m (6,562 ft.)
Typical noise emission	≤51 dB(A)
Power loss in night mode	< 1.8 W
Maximum data volume per inverter with Speedwire/Webconnect	550 MB/month
Additional data volume when using the Sunny Portal live interface	600 kB/hour
Topology	transformerless
Cooling concept	OptiCool: temperature-controlled fan
Enclosure type rating in accordance with UL50	Type 3R



Protection class	I
Grid configurations	480 V / 277 V WYE
Approvals and national standards, as per 05/2013	UL1741 CAN/CSA C22.2 No. 107.1-01

## 12.3 Protective Devices

DC reverse polarity protection	Short-circuit diode
AC short-circuit current capability	Current control
Grid monitoring	SMA Grid Guard 3
Maximum permissible fuse protection	50 A
Ground-fault monitoring STP 12000TL-US-10	Insulation monitoring: $R_{iso} > 417 \text{ k}\Omega$
Ground-fault monitoring STP 15000TL-US-10	Insulation monitoring: $R_{iso} > 333 \text{ k}\Omega$
Ground-fault monitoring STP 20000TL-US-10	Insulation monitoring: $R_{iso} > 250 \text{ k}\Omega$
Ground-fault monitoring STP 24000TL-US-10	Insulation monitoring: $R_{iso} > 208 \text{ k}\Omega$
All-pole sensitive residual-current monitoring unit	Available
Arc fault detection AFCI, type 1, listed according to UL1699B	Available

## 12.4 Climatic Conditions

Extended temperature range	-25 °C to +60 °C (-13 °F to +140 °F)
Extended humidity range	0% to 100%
Extended air pressure range	79.5 kPa to 106 kPa

## 12.5 Equipment

DC connection	Screw terminals
AC connection	Spring-cage terminal
SMA Webconnect Data Module	RJ45, as standard

## 12.6 Torques

Upper enclosure lid screws	6.0 Nm (53 lb-in.)
Lower enclosure lid screws	2.0 Nm (17.7 lb-in.)
Screws for DC protective cover	3.5 Nm (31 lb-in.)

Screw for grounding	5.8 Nm (51 lb-in.)
Screw terminal DC input	5.0 Nm (44 lb-in.)

## 12.7 Data Storage Capacity

Daily energy yields	63 days
Daily yields	30 years
Event messages for users	250 events
Event messages for installers	250 events

## 13 Accessories

You will find the corresponding accessories and spare parts for your product in the following overview. If required, these can be ordered from SMA or your distributor.

<b>Designation</b>	<b>Brief description</b>	<b>SMA order number</b>
RS485 data module	Retrofit kit RS485 communication interface	DM-485CB-US-10
SMA Connection Unit 1000-US	String-Combiner with DC load-break switch for connecting eight strings, up to 1,000 V	CU1000-US-10

# 14 Compliance Information

## FCC Compliance

This device complies with Part 15 of the FCC Rules. Operation is subject to the following conditions:

1. This device may not cause harmful interference, and
2. This device must accept any interference received, including interference that may cause undesired operation.

NOTE: This equipment has been tested and found to comply with the limits for a Class B digital device, pursuant to Part 15 of the FCC Rules. These limits are designed to provide reasonable protection against harmful interference in a residential installation. This equipment generates, uses, and can radiate radio frequency energy and if not installed and used in accordance with the instructions, may cause harmful interference to radio communications. However, there is no guarantee that interference will not occur in a particular installation. If this equipment does cause harmful interference to radio or television reception, which can be determined by turning the equipment off and on, the user is encouraged to try to correct the interference by one or more of the following measures:

- Reorient or relocate the receiving antenna.
- Increase the separation between the equipment and the receiver.
- Connect the equipment into an outlet on a circuit different from that to which the receiver is connected.
- Consult the dealer or an experienced radio/TV technician for help.

The user is cautioned that changes or modifications not expressly approved by SMA America, LLC could void the user's authority to operate this equipment.

## IC Compliance

This device complies with Industry of Canada licence-exempt RSS standard(s). Operation is subject to the following two conditions:

- This device may not cause interference, and
- This device must accept any interference, including interferences that may cause undesired operation of the device.

## 15 Contact

If you have technical problems with our products, contact the SMA Service Line. We need the following information in order to provide you with the necessary assistance:

- Inverter device type
- Inverter serial number
- Inverter firmware version
- Special country-specific settings of the inverter (if applicable)
- Type and number of PV modules connected
- Mounting location and mounting altitude of the inverter
- Event number and error message of the inverter
- Optional equipment, e.g. communication products

United States/ Estados Unidos	SMA America, LLC Rocklin, CA	Toll free for USA, Canada and Puerto Rico / Llamada gratuita en EE. UU., Canadá y Puerto Rico: +1 877-MY-SMATech (+1 877-697-6283) International / Internacional: +1 916 625-0870
Canada/ Canadá	SMA Canada, Inc. Toronto	Toll free for Canada / gratuit pour le Canada: +1 877-MY-SMATech (+1 877-697-6283)

**SMA Solar Technology**

**[www.SMA-Solar.com](http://www.SMA-Solar.com)**



Your SMA Distributor  
SOLARIS  
720-474-6050  
[www.solaris-shop.com](http://www.solaris-shop.com)

