



# **SolarEdge Firefighter Gateway Installation Guide**

Version 1.1



# Disclaimers

## Important Notice

---

Copyright © SolarEdge Technologies Inc. All rights reserved.

No part of this document may be reproduced, stored in a retrieval system or transmitted, in any form or by any means, electronic, mechanical, photographic, magnetic or otherwise, without the prior written permission of SolarEdge Technologies Inc. (also referred to herein as "SolarEdge").

This document is solely for the use of SolarEdge customers and employees.

The material furnished in this document is believed to be accurate and reliable. However, SolarEdge assumes no responsibility for the use of this material. SolarEdge reserves the right to make changes to the material at any time and without notice. You may refer to the SolarEdge website ([www.solaredge.com](http://www.solaredge.com)) for the most updated version of this and other documents.

All company and brand products and service names are trademarks or registered trademarks of their respective holders.

Patent marking notice: <http://www.solaredge.com/groups/patent>

The general terms and conditions of purchase of SolarEdge products shall apply.

The content of these documents is continually reviewed and amended, where necessary. However, discrepancies cannot be excluded. No guarantee is made for the completeness of these documents.

Please note: This product is intended to provide remote shutdown of the SolarEdge PV harvesting system, to enable safer access to a building in the event of fire. This product DOES NOT reduce the risk of fire or protect firefighters or others accessing a building in the event of a fire.

**If the RS485 communication between the firefighter gateway and the SolarEdge inverter(s) is disconnected for any reason (including fire), the firefighter gateway LCD will display "No Communication" or "Partial Com.". In this case, the firefighter gateway cannot be relied upon to disconnect the SolarEdge PV harvesting system.**

## FCC Compliance

---

This equipment has been tested and found to comply with the limits for a Class B digital device, pursuant to part 15 of the FCC Rules. These limits are designed to provide reasonable protection against harmful interference in a residential installation. This equipment generates, uses and can radiate radio frequency energy and, if not installed and used in accordance with the instructions, may cause harmful interference to radio communications. However, there is no guarantee that interference will not occur in a particular installation. If this equipment does cause harmful interference to radio or television reception, which can be determined by turning the equipment OFF and ON, you are encouraged to try to correct the interference by one or more of the following measures:

- Reorient or relocate the receiving antenna.
- Increase the separation between the equipment and the receiver.
- Connect the equipment into an outlet on a circuit different from that to which the receiver is connected.
- Consult the dealer or an experienced radio/TV technician for help.

Changes or modifications not expressly approved by the party responsible for compliance may void the user's authority to operate the equipment.

# Table of Contents

<b>Disclaimers</b> .....	<b>1</b>
Important Notice.....	1
FCC Compliance.....	1
<b>Table of Contents</b> .....	<b>2</b>
<b>About This Guide</b> .....	<b>4</b>
<b>Support and Contact Information</b> .....	<b>5</b>
<b>Handling and Safety Instructions</b> .....	<b>6</b>
<b>Chapter 1: Introducing the SolarEdge Firefighter Gateway</b> .....	<b>7</b>
Overview .....	7
Firefighter Gateway User Interfaces.....	8
LCD and LCD-Menu Buttons.....	8
Communication Connectors .....	9
Other Interfaces .....	9
<b>Chapter 2: Installing the SolarEdge Firefighter Gateway</b> .....	<b>10</b>
Safety.....	10
Transport and Storage .....	10
Package Contents.....	10
Installation Equipment.....	10
Installation Guidelines .....	11
Installation Workflow.....	11
Mounting the Firefighter Gateway.....	12
Connecting the Firefighter Gateway to AC.....	13
<b>Chapter 3: Connecting Emergency Stop Button or Fire Alarm Control</b> .....	<b>14</b>
Overview .....	14
Connecting and Configuring an Emergency Stop Button to the Gateway.....	16
<b>Chapter 4: Connecting the Firefighter Gateway to the SolarEdge Installation</b> .....	<b>18</b>
Overview .....	18
Connecting and Configuring the RS485 .....	18
Verifying the Connection .....	22
Troubleshooting the RS485 Communication.....	22
<b>Chapter 5: Emergency System Shutdown</b> .....	<b>24</b>
<b>Chapter 6: LCD – Status Screens and Setup Options</b> .....	<b>26</b>
Status Screens .....	26
Main Firefighter Gateway Status.....	26
ID Status.....	26
Server Communication Status.....	26
IP Status.....	27
ZigBee Status .....	27
Communication Ports Status.....	28

Setup Menu Options .....	28
Language .....	29
Communication.....	30
Remote Shutdown.....	32
Display .....	32
Maintenance.....	32
Information .....	33
<b>Chapter 7: Setting Up Monitoring through the Firefighter Gateway (Optional) .....</b>	<b>34</b>
Communication Dataflow .....	34
Communication Types .....	34
Creating an Ethernet (LAN) Connection.....	35
Overview.....	35
Ethernet Communication Configuration Options .....	35
Connecting and Configuring LAN.....	36
Troubleshooting Ethernet Communication.....	37
Additional Connection Options.....	38
Creating a Wireless ZigBee Connection.....	38
Creating a GSM Connection.....	38
<b>Appendix A: Technical Specifications .....</b>	<b>39</b>

# About This Guide

This user guide is intended for Photovoltaic (PV) installers, technicians, maintainers and integrators who use the SolarEdge power harvesting system.

This guide describes the process of installing and configuring the SolarEdge Firefighter gateway (also referred to herein as the "gateway").

This guide assumes that the SolarEdge power harvesting system is already installed and commissioned. For additional information about how to install and commission the SolarEdge power harvesting system, refer to the relevant inverter or safety and monitoring system (SMI) installation guide.

The guide includes the following chapters:

- **Chapter 1: Introducing the SolarEdge Firefighter Gateway**, page 7, introduces the SolarEdge firefighter gateway.
- **Chapter 2: Installing the SolarEdge Firefighter Gateway**, page 10, describes how to install the SolarEdge firefighter gateway.
- **Chapter 3: Connecting Emergency Stop Button or Fire Alarm Control**, page 14, describes how to connect and use an external emergency stop button.
- **Chapter 4: Connecting the Firefighter Gateway to the SolarEdge Installation**, page 18, describes how to connect the firefighter gateway to inverters or Safety and Monitoring Interface (SMI) using the RS485 bus connection.
- **Chapter 5: Emergency System Shutdown**, page 24, describes how to use the emergency stop button to stop the power production.
- **Chapter 6: LCD – Status Screens and Setup Options**, page 26, describes how to configure the SolarEdge gateway and how to identify its status.
- **Chapter 7: Setting Up Monitoring through the Firefighter Gateway (Optional)**, page 34, describes how to set up communication through the SolarEdge firefighter gateway to the SolarEdge monitoring portal
- **Appendix A: Technical Specifications**, page 39, provides the electrical and mechanical specifications of the SolarEdge Gateway device.

For further information, datasheets and the most up-to-date certifications for various products in different countries, please visit the SolarEdge website: [www.solaredge.com](http://www.solaredge.com)

# Support and Contact Information

If you have technical queries concerning our products, please contact us:

US & Canada	1877 360 5292	<a href="mailto:support@solaredge.us">support@solaredge.us</a>
Germany	+49 89-45459730	<a href="mailto:support@solaredge.de">support@solaredge.de</a>
France	0800917410	<a href="mailto:support@solaredge.fr">support@solaredge.fr</a>
Belgium	080073041	<a href="mailto:support@solaredge.be">support@solaredge.be</a>
Italy	800 784 824	<a href="mailto:support@solaredge.it">support@solaredge.it</a>
Netherlands	08000221089	<a href="mailto:support@solaredge.com">support@solaredge.com</a>
United Kingdom	08002061058	
Greece	00800125574	
Israel	+972 73 240-3118	
Australia	1800149229	
Worldwide	+972 73 240-3118	
Fax	+972 73 240-3117 US: +1 (530) 273-2769	

Before contacting SolarEdge, please ensure you have the following information readily available:

- The communication method to the SolarEdge server
- The product serial number as appears on its label. The serial number can also be viewed in the ID Status screen, as described on page 26.
- Your software version, which can be viewed in the ID Status screen, as described on page 26

# Handling and Safety Instructions

During installation, testing and inspection, adherence to the following handling and safety instructions is mandatory.

The following safety symbols may be used in this document. Familiarize yourself with the symbols and their meaning before installing or operating the system.



**WARNING!**

Denotes a hazard. It calls attention to a procedure that, if not correctly performed or adhered to, could result in **injury or loss of life**. Do not proceed beyond a warning note until the indicated conditions are fully understood and met.



**CAUTION:**

Denotes a hazard. It calls attention to a procedure that, if not correctly performed or adhered to, could result in **damage or destruction of the instrument**. Do not proceed beyond a caution sign until the indicated conditions are fully understood and met.



**NOTE:**

Denotes additional information about the current subject.



**IMPORTANT SAFETY FEATURE:**

Denotes information about safety issues.



# Chapter 1: Introducing the SolarEdge Firefighter Gateway

## Overview

The firefighter gateway provides centralized safety management of SolarEdge systems: If the firefighter gateway is properly installed and fully functional, firefighters can halt production of a SolarEdge photovoltaic (PV) power harvesting system and have visual acknowledgement that the installation outputs a safe DC voltage. The power production can be stopped either manually through an emergency stop button or automatically through a Fire Alarm Control Panel system. This stops the AC production and reduces string DC voltage to a safe voltage using the unique SafeDC™ feature .

The firefighter gateway can connect to SolarEdge inverters and to Safety and Monitoring Interfaces (SMIs). Although DC voltage can be reduced directly from the inverter/SMI or by shutting off the AC voltage, using the firefighter gateway provides a clear indication of DC voltage shutdown. The firefighter gateway enables shutting off the installation from a distance of up to 1,000m, while getting visual feedback that the PV installation is safe.

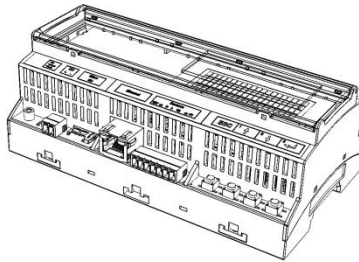

Figure 1: The SolarEdge Firefighter Gateway



Figure 2: The SolarEdge Firefighter Gateway Connections

# Firefighter Gateway User Interfaces

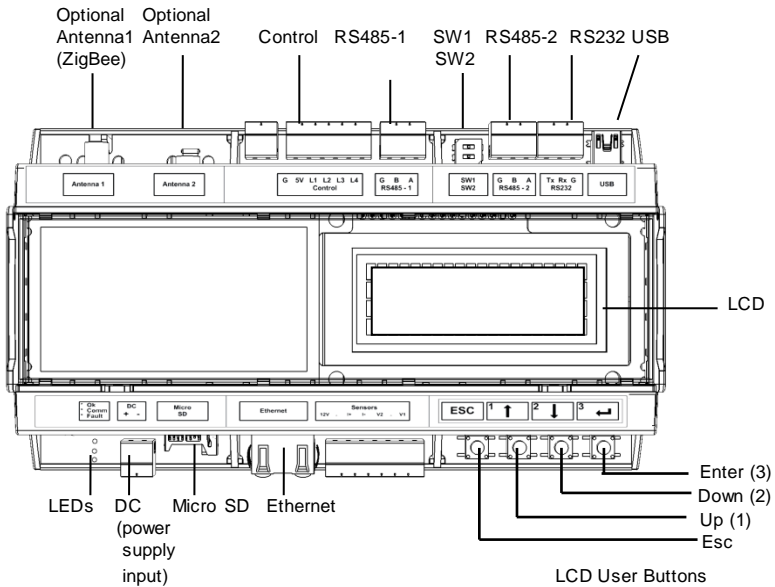

Figure 3: Gateway Interfaces

## LCD and LCD-Menu Buttons

The LCD screen displays status information of the SolarEdge firefighter gateway and various menus for configuration options. The LCD panel and buttons are used during the following processes:

- **Operational Mode:** The LCD panel allows checking that the gateway is working properly. Refer to *Status Screens* on page 26 for a description of this option. Use the LCD user buttons to toggle through the informative displays and select options.
- **Setup:** After mounting the gateway, the installer may perform basic gateway configuration, as described in *Setup Menu Options* on page 28.

Four buttons are used for controlling the LCD menus (see Figure 3).

- **Esc:** Moves the cursor to the beginning of the parameter, goes to the previous menu, and cancels a value change.
- **Up (1), Down (2):** Moves the cursor between menu options, moves among the characters of a parameter, and toggles between possible characters when setting a value.
- **Enter (3):** Selects a menu option or accepts a value change. Also used to enable LCD backlight.

## Communication Connectors

---

- **Antenna1:** Used for optional wireless ZigBee antenna connection (refer to *Creating a Wireless ZigBee Connection* on page 38)
- **Antenna2:** Currently not installed
- **RS485-1 and RS485-2:** Used for connecting external devices to the gateway (refer *Chapter 4: Connecting the Firefighter Gateway to the SolarEdge Installation* on page 18)
- **RS232:** Enables connection of the SolarEdge gateway to an external SolarEdge GSM modem (refer to *Creating a GSM Connection* on page 38)
- **USB:** Enables PC/laptop connection for using the SolarEdge configuration tool.
- **Ethernet:** Enables connecting the SolarEdge gateway to the SolarEdge monitoring portal through an Ethernet switch/router (refer to *Creating an Ethernet (LAN) Connection* on page 34). The Ethernet switch/router should be connected to the Internet.

## Other Interfaces

---

- **Control:** Used for connection to an external emergency stop button (refer to *Chapter 3: Connecting Emergency Stop Button or Fire Alarm Control* on page 14).
- **SW1/SW2:** RS485-1/2 termination
- **DC:** Used for the power supply input as described in *Connecting the Firefighter Gateway to AC* on page 13
- **Micro SD:** Used for field software upgrade
- **Sensors:** Not applicable
- **LEDs:** All LEDs are ON while the SolarEdge gateway is powered up or configured.

# Chapter 2: Installing the SolarEdge Firefighter Gateway

## Safety

**CAUTION:**

**For North America only:** The product's communication with external devices must not use wires that span more than one building, as per the UL 60950-2 standard.

## Transport and Storage

Transport the SolarEdge gateway in its original packaging, without exposing it to unnecessary shocks. If the original package is no longer available, use a similar box, which can be fully closed.

Store the SolarEdge gateway in a dry place where ambient temperatures are -40°C (-40°F) to +60°C (140°F).

## Package Contents

- Firefighter gateway
- 100-240VAC to 12VDC power supply with an interchangeable AC plug (US, EU, AUS, UK)
- Accessory kit including:
  - Three 3-pin terminal blocks
  - One 6-pin terminal block

## Installation Equipment

Standard tools can be used during the installation of the SolarEdge gateway. The following is a recommendation of the equipment needed for installation:

- Emergency stop button (recommended: a button with a locking feature, which stays mechanically locked in the off position until turning it clockwise to release it), or a fire alarm control system with relay output interface
- Allen screwdriver for M5/M6 screw types
- Standard flat head screwdrivers set
- Voltage tester screwdriver
- Drill and 4mm diameter bits
- Wire cutters
- Wire strippers
- Voltmeter
- Three twisted wires or four-wire twisted pair cable
- For installing the communication options: CAT5/6 Ethernet cable

## Installation Guidelines

The following requirements apply when locating and mounting the SolarEdge Gateway:

- The SolarEdge gateway is suitable for mounting indoors. For outdoor installation, use an external outdoor enclosure (not provided by SolarEdge).
- The SolarEdge gateway must always remain in an ambient temperature of  $-20^{\circ}\text{C}$  ( $-4^{\circ}\text{F}$ ) to  $+60^{\circ}\text{C}$  ( $140^{\circ}\text{F}$ ).
- Cable specifications:

Connection Type	Cable Type	Maximum Length
RS485 communication bus (per RS485 port)	Three twisted wires or 4-wire twisted pair cable (two twisted pairs). Recommended wire size: 20 AWG / $0.52\text{ mm}^2$	1,000m (3,330 ft)
Ethernet	CAT5/6	100m (325 ft).

- The SolarEdge gateway power supply requires a socket outlet with a grid voltage of 100 V - 240 V (50 Hz/60 Hz).
- Protect the SolarEdge gateway from dust, wet conditions, corrosive substances and vapors.

## Installation Workflow

The following provides an overview of the workflow for installing and setting up the firefighter gateway

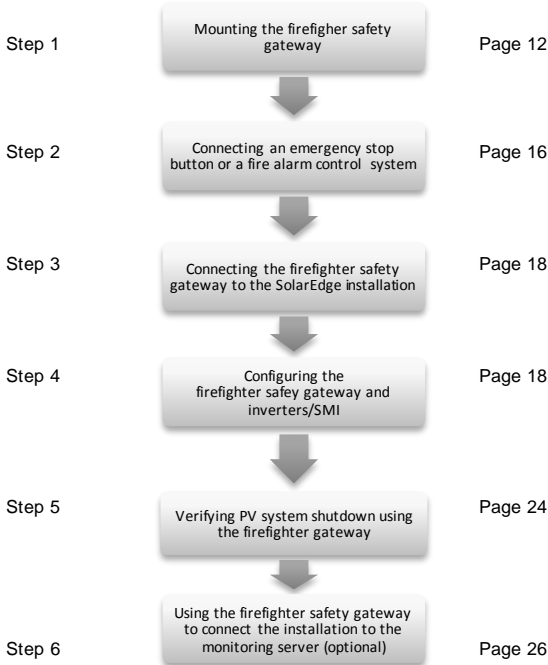

## Mounting the Firefighter Gateway

The SolarEdge gateway can be installed on a wall or on a DIN rail.

**▶ To mount the SolarEdge gateway on a wall:**

- 1 Determine the mounting location. Leave clearance from all sides of the SolarEdge gateway for cover opening, cable connection and routing.
- 2 Open the clips at the rear of the gateway by pushing the clips outwards.

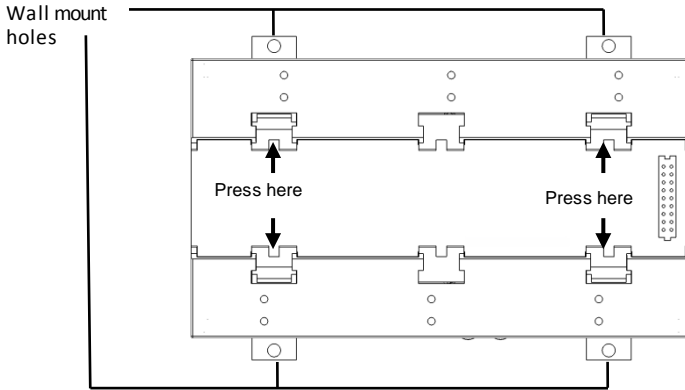

Figure 4: Clips in Open Position

- 3 Position the device on the wall with the open clips, as shown in Figure 4. Mark points through the holes of the clips and drill holes using a 4mm diameter drill bit.
- 4 Mount the unit using screw anchors and screws (use 3.5mm diameter screws, 20mm minimum length, not provided by SolarEdge).

**▶ To mount the SolarEdge gateway on a DIN rail:**

- 1 Ensure that the clips are closed, as shown below:

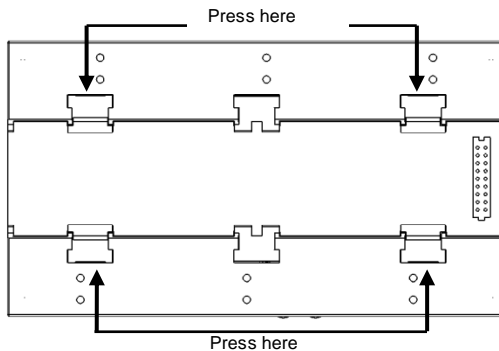

Figure 5: Clips in Closed Position

- 2 Hook the two lower clips of the SolarEdge gateway onto the lower edge of the DIN rail.
- 3 Press the SolarEdge gateway upwards and snap it into the upper edge of the DIN rail. When on the rail, the clip "grips" the rail on both the top and bottom lips of the rail.  
To remove the DIN clip from the rail, simply push upwards on the DIN clip (thereby compressing the springs in the bottom), pivot the top of the clip off of the rail, and then move the whole clip down to also release the bottom of the clip. No screwdrivers or special tools are required.
- 4 The following figure shows the gateway's rear side when mounted on a DIN rail.

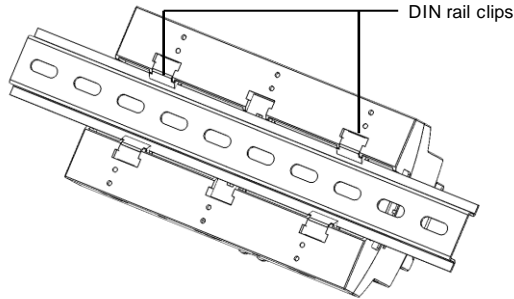

Figure 6: Gateway Mounted on a DIN Rail

## Connecting the Firefighter Gateway to AC

For connecting to power, use the supplied power supply:

- 1 Insert the power supply DC connector to the SolarEdge gateway (see Figure 3).
- 2 Connect the power supply to the AC mains. The LEDs are lit momentarily to indicate power connection (see Figure 3)



### CAUTION

If you use a non-SolarEdge power supply, check that it has 12Vdc/1A output ratings, and that it is certified to UL/CSA/IEC60950-1 2ed standards. Limited Power Source output, NEC class 2. Verify the power supply polarity as marked on the gateway.

# Chapter 3: Connecting Emergency Stop Button or Fire Alarm Control

## Overview

An external emergency stop button (not supplied by SolarEdge) should be connected to the firefighter gateway, in order to shut down the PV system in case of emergency. Pressing the emergency stop button starts the shutdown sequence of the PV system. Preferably, use a button with a locking feature that stays mechanically locked in the off position until you turn it clockwise a quarter turn to unlock and release it.

The firefighter gateway can also be connected to a fire alarm control unit that has a relay output. The relay output of the fire alarm control has the same functionality as the button. You can connect both a stop button and a relay together to the same firefighter gateway, or two stop buttons or two relays.

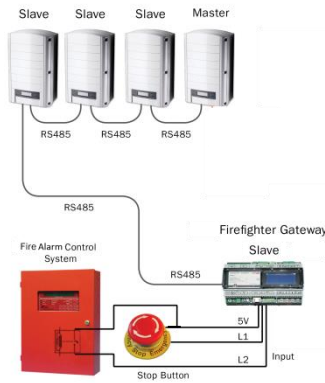

Figure 7: Example: Emergency Stop Button and Fire Alarm System Connection

The emergency stop button(s) or relay(s) connect to the L1 or L2 ports on the **Control** connector of the gateway, between 5V and L1 / L2/both. In the following sections, the instructions refer to L1, however applies to L2 as well.

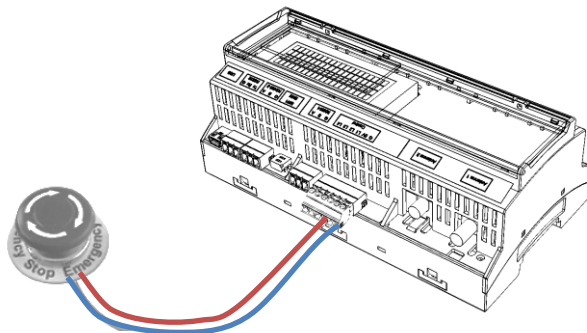
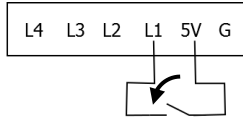

Figure 8: Emergency Stop Button Connection



There are two types of contact states in Emergency Stop buttons/relays:

- **Normally open (NO)** – the contacts are open until closed by operation of the switch. This type of switch should be connected in the following manner:



This installation is safe when L1/L2 has 5V input, and active with L1/L2 is not connected. This is considered Normal polarity in the configuration screen.

- **Normally closed (NC)** – the contacts are closed until opened by operation of the switch. This type of switch should be connected in the following manner:

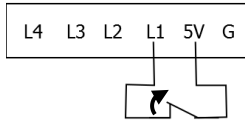

This installation is safe when L1/L2 is not connected and active when L1/L2 is 5V. This is considered Reverse polarity in the configuration screen.

- If you connect more than one firefighter gateways to the same emergency stop button, they should connect to the same grounding, as in the following example:

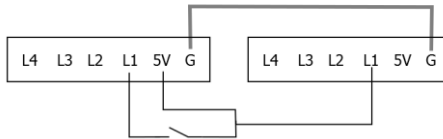

- In some fire alarm control systems, the switch is grounded internally. This type of switch should be connected in the following manner, sharing ground between the control system and the firefighter gateway.

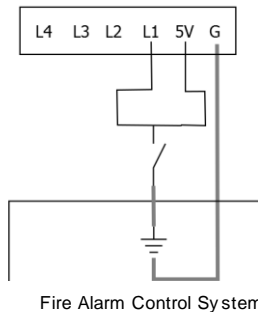

In these cases, a Normally Open relay will connect L1/L2 to ground for safety, and when active, L1/L2 is 5V. This will be configured as a reverse polarity switch.

# Connecting and Configuring an Emergency Stop Button to the Gateway

- 1 Depending on the button/relay type, connect L1/L2, 5V and Ground as described above. Use wire size 20 AWG/0.52mm<sup>2</sup>: Insert the ends of wires into the ports of the supplied 6-pin terminal block.

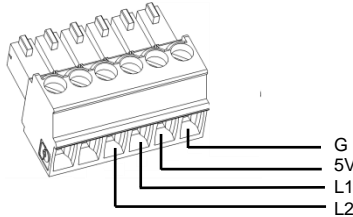

Figure 9: 6-pin Terminal Block

- 2 Insert the terminal block into the **Control** connector on the firefighter gateway.
- 3 Verify that the SolarEdge gateway is connected to a power outlet.
- 4 Press the **Enter** button until the following message is displayed:

```

Please enter
Password
*****
    
```

The gateway is now in Setup mode and all its LEDs are lit.

- 5 Use the three-right-most LCD buttons to type in the following password: **12312312**. The following menu is displayed:

```

Language <eng>
Communication
Fire Safety
Display
Maintenance
Information
    
```

- 6 Short-press the up/down buttons to scroll to the **Fire Safety** menu. Press the Enter key to select it. The fire safety parameters are displayed:

```

L1 Polarity <Norm.>
L2 Polarity <Norm.>
Safe Vdc <120V>
Clr Alarm Mode <M>
Clear Alarm
    
```

- 7 Set the following:
  - **L1/L2 Polarity:** The lines polarity - Normal (default) or Reverse
    - Normal – safety will be activated when L1/L2 has 5V
    - Reverse – Safety will be activated when L1/L2 is connected to ground or not connected.
  - **Safe Vdc:** Threshold value for safe Vdc: When the maximum DC voltage (of all connected devices) reaches this threshold, the PV system will be considered safe and the display will show *Safe DC* in the main gateway status screen. You may set the threshold in the range between 30 -120V (default 120V)

- **Clr Alarm Mode:** Select the method to return to normal operation as soon as the emergency stop button is released:
  - Automatic (default) – when releasing the stop button or relay, the system immediately returns to normal power production.
  - Manual – when releasing the stop button or relay, the system will *not* return to normal operation unless the user manually clears the alarm by selecting **Clear Alarm** (below). Use this option if the button does not have the locking feature, the relay in the control system may open unexpectedly, or if the user requires this added step.
- **Clear Alarm:** Used to allow normal operation. Appears only if the Clr Alarm Mode parameter (above) is set to Manual, and the installation is in remote safety shutdown

# Chapter 4: Connecting the Firefighter Gateway to the SolarEdge Installation

## Overview

The SolarEdge firefighter gateway connects to the PV system installation using the RS485 communication option. The RS485 option enables creating a chain (bus) of up to 31 slave SolarEdge devices, connected to one master, which can be another SolarEdge device or the SolarEdge firefighter gateway.

The following is an example of a slave gateway connected to a chain of slave inverters (one inverter is the master).

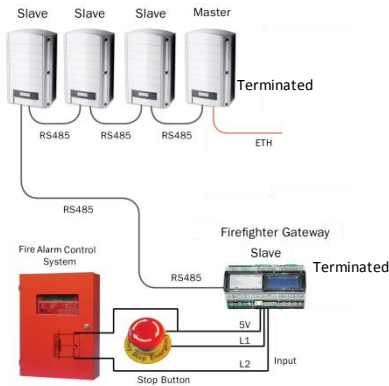

Figure 10: Example of RS485 Connection

The following sections describe how to connect the RS485 bus and how to configure its components.

## Connecting and Configuring the RS485

The RS485 bus uses a three-wire cable connecting the RS485-1/2 terminal blocks on the SolarEdge gateway to the RS485 input of the inverters/SMI.

### ► To connect the RS485 communication bus between inverters/SMIs and SolarEdge gateway:

- 1 Use one of the supplied 3-pin terminal blocks: Loosen the screws and insert the wire ends into the A, B and G pins. For connections longer than 10m use twisted pair wires for A and B wires.

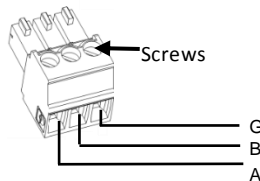

Figure 11: 3-pin Terminal Block

- 2 Choose either RS485-1 or RS485-2 for connection. Connect the 3-pin terminal block to the designated port on the gateway.

**NOTE:**

RS485-1 is configured as SolarEdge device by default, therefore RS485-1 is recommended as the RS485 bus connection point.

- 3 If the gateway is at the end of the RS485 chain, terminate the gateway by switching a termination dipswitch to ON. The switches in the SolarEdge gateway are marked **SW1** for the RS485-1 port termination and **SW2** for the RS485-2 port termination, as shown below:

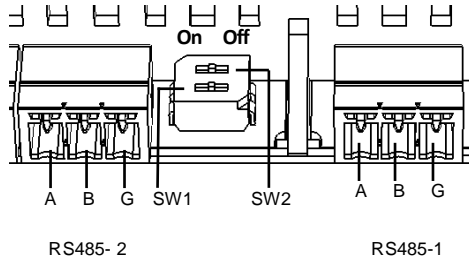

**Figure 12: RS485 Connectors and Termination Switches**

- 4 Open the inverter/SMI cover as described in their manual.
- 5 Remove the seal from one of the openings in communication gland #2 of the inverter and insert the cable through the opening.
- 6 Pull out the 9-pin RS485/RS232 terminal block connector, as shown below:

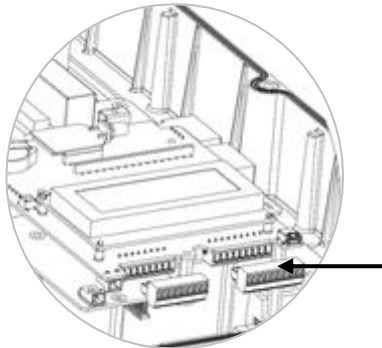

**Figure 13: The RS485/RS232 Block Terminal In the Inverter/SMI**

- 7 Loosen the screws of pins **B**, **A** and **G** on the left of the RS-485 block terminal:
  - For inverter: RS485-1 pins (left-most)
  - For SMI: RS485-1 (recommended, as this is the default configuration), or RS485-2

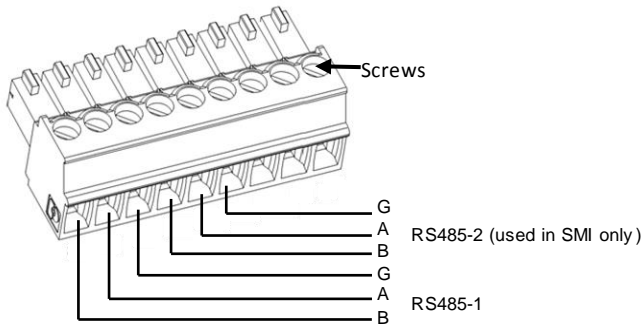

**Figure 14: RS485/RS232 Terminal Block**

- 8** Insert the ends of wires into the **G**, **A** and **B** pins shown above. You can use any color wire for each of the **A**, **B** and **G** connections, as long as the same color wire is used for all **A** pins, the same color for all **B** pins and the same color for all **G** pins.
- 9** Connect all **B**, **A** and **G** pins in all inverters/SMI. The following figure illustrates this connection schema (the illustration applies to both inverters and SMI):

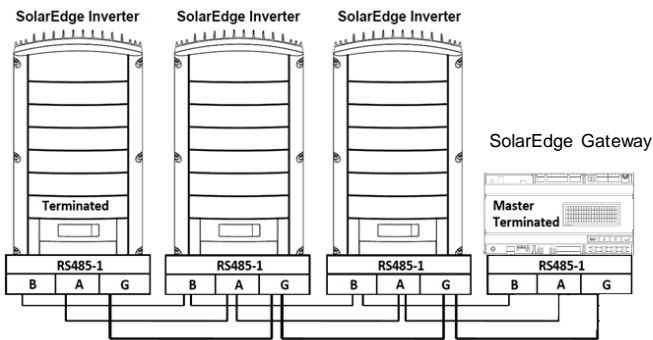

**Figure 15: Connecting SolarEdge Devices (Inverters or SMI) in a Chain**



**NOTE:**

Do not cross-connect **B**, **A** and **G** wires.  
 For inverters - Do not insert wires into RS485-2 pins.

- 10** Tighten the terminal block screws.
- 11** Push the RS485 terminal block firmly all the way into the communication board.

- 12** Terminate the inverters/SMIs at the two ends of the chain by switching a termination dipswitch inside the inverter/SMI to ON (move the switch to the top). The switch is located on the communication board and is marked **SW7**.

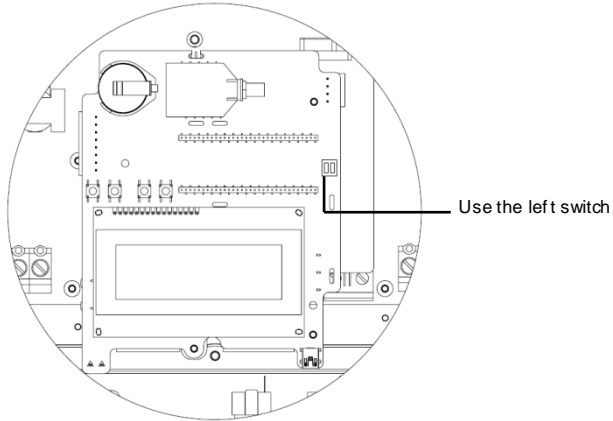

Figure 16: RS485 Termination Switch



**NOTE:**

Only the first and the last SolarEdge devices in the chain should be terminated. The other devices in the chain should have the termination switch OFF.

► **To configure the RS485 communication bus with SolarEdge inverters/SMI:**

By default, all SolarEdge devices are pre-configured as slaves. Slaves can be further configured using the **RS485-x Conf** option in the Communication menu.

One device must be set as the master on the RS485 bus. Any one of the SolarEdge devices may be the master (firefighter gateway, inverter, or SMI). If you connect the installation to the SolarEdge monitoring portal, the device used to connect to the server must be the master.

The following describes how to configure the master device.

- 1** Press the **Enter** button until the following message is displayed:

```

P l e a s e   e n t e r
P a s s w o r d
* * * * *
  
```

The gateway is now in Setup mode and all its LEDs are lit.

- 2** Use the three-right-most LCD buttons to type in the following password: **12312312**. The following menu is displayed:

```

L a n g u a g e   < e n g >
C o m m u n i c a t i o n
F i r e   S a f e t y
D i s p l a y
M a i n t e n a n c e
I n f o r m a t i o n
  
```

- 3 Short-press the arrow buttons to scroll to the **Communication** menu. Press the Enter key to select it.
- 4 Select **Server** → **RS485-X Conf** (X=1 or 2 depending on the specific physical port connection).
- 5 To configure the master, select the following in the LCD menu:
  - Communication → RS485-1 Conf → Device Type → *SolarEdge*
  - RS485-1 Conf → Protocol → *Master*
  - RS485-1 Conf → *Slave Detect*

The system starts automatic detection of the SolarEdge slave inverters connected to the master gateway. The gateway should report the correct number of slaves. If not, verify the connections and terminations. Verify that only one master is configured on the bus.
- 6 Close the inverter/SMI cover and start power production.
- 7 On the firefighter gateway main status screen, verify that "Dev. On", "Dev. Safe" and "Max Vdc" values are set according to your setup. That is, if you connected three slaves:
  - Dev. On = 3/3
  - Dev. Safe = 0/3
  - Max Vdc = Voltage of the slave with highest DC voltage

```
P V   N o r m a l   O p e r a t i o n
0 0 3 / 0 0 3   D e v .   O N
0 0 0 / 0 0 3   D e v .   S a f e
M a x .   V d c :   1 5 0   V
```

The PV installation is now connected to the firefighter gateway. Power production can now be stopped at emergencies.

- 8 Test the Emergency system shutdown as described in *Chapter 5: Emergency System Shutdown* on page 24.

## Verifying the Connection

- 1 After connection, a message similar to the following appears in the main status screen (see also *Main Firefighter Gateway Status* on page 26):

```
P V   N o r m a l   O p e r a t i o n
X X X / Y Y Y   D e v .   O N
Z Z Z / Y Y Y   D e v .   S a f e
M a x .   V D C :   7 5 0   V
```

- 2 Assuming that the system is producing power, check:
  - XXX - number of devices that are connected to the gateway
  - YYY - number of devices (inverters and SMIs) that are connected and ON
  - ZZZ=0 - number of devices in Safe mode, that is, disconnected or shut down.
- 3 If **No Communication** or **Partial Com.** appear in the first line, refer to *Troubleshooting the RS485 Communication*, below.

## Troubleshooting the RS485 Communication

- 1 If **No Communication** is displayed on the firefighter gateway, perform the following:
  - Verify that the RS485 cable is connected to all inverters. Check the connections between the first inverter in the chain and the other inverters.
  - Verify that one of the devices is defined as the master and that slaves were detected, as described in Step 5 above.



- 2** If **Partial Com.** is displayed on the firefighter gateway, one or more inverters are disconnected from the bus. Perform the following:
- Verify that the RS485 cable is connected to all inverters.
  - Check the *Server Communication Status* screen of all the inverters. The following should appear:

```
S e r v e r : R S 4 8 5
S t a t u s :           O K
```

If the message **Master Not Found**, check the connections to the master device and fix if required.

# Chapter 5: Emergency System Shutdown

In emergencies, use the emergency stop button to stop power production.

Use this procedure also to test the PV system shutdown using the firefighter gateway.

**To stop PV harvesting system power production:**

- 1 On the firefighter gateway, press the Enter button to light up the LCD and display the main status screen. Check that a message similar to the following appears, and that the first line does NOT display **No Communication** or **Partial Com.**:

```
P V   N o r m a l   O p e r a t i o n
0 0 3 / 0 0 3   D e v .   O N
0 0 0 / 0 0 3   D e v .   S a f e
M a x .   V d c :   1 5 0   V
```



**WARNING!**

If the RS485 communication between the firefighter gateway and inverters is disconnected for any reason (including damage to cables caused by a fire), the firefighter gateway LCD will display "No Communication" or "Partial Com". In this case, the firefighter gateway CANNOT be relied upon to disconnect the SolarEdge PV harvesting system.

- 3 Press the emergency stop button. The PV system starts the shutdown sequence.
- 4 On the firefighter gateway LCD, check the main status screen. A message similar to the following should appear:

```
P V   S h u t t i n g   D o w n
0 0 1 / 0 0 3   D e v .   O N
0 0 2 / 0 0 3   D e v .   S a f e
M a x .   V d c :   1 5 0   V
```

The status changes to **PV Reducing Voltage**. The shutdown is immediate but safe indication will take 3 to 5 minutes until the inverter capacitors are discharged.

Upon reaching safety voltage (default: 120V), the following message appears on the firefighter gateway LCD:

```
P V   S y s t e m   s a f e
```



**WARNING!**

If the communication between the firefighter gateway and the inverters / SMIs is not available during the shutdown sequence, the following message appears on the LCD:

```
F a i l e d   t o   S h u t d o w n
```

If this occurs:

1. Shutdown the AC power to the inverters / SMIs
2. Wait 3 to 5 minutes until the capacitors are discharged.

On the inverters/SMIs LCD display, the following message appears upon reaching safe voltage:

```
F i r e f i g h t e r
R e m o t e   S h u t d o w n
```



**NOTE**

The *Maintenance* submenu in the inverters/SMIs LCD includes a Clear Alarm option that appears only in remote shutdown. This enables clearing the remote shutdown state for a specific device if required.

- 5 Disconnect the AC power to the inverters/SMIs.

▶ **To regain system normal operation:**

- 1 Release the emergency stop button.
- 2 Turn ON the AC power.
- 3 Do one of the following:
  - If you set the **Clear Alarm Mode** in the firefighter gateway to **Automatic** (refer to *Connecting and Configuring an Emergency Stop Button to the Gateway* on page 16), check the firefighter gateway main status screen displays the status **PV Normal Operation**.
  - If you set the **Clear Alarm Mode** in the firefighter gateway to **Manual**, do the following:
    - a. Enter Setup mode, as described in *Setup Menu Options* on page 28.
    - b. Select **Fire Safety** → **Clear Alarm** → **Yes**. the following is displayed:

```
C l e a r i n g   A l a r m   ...
```

- c. If the alarm was cleared, the following is displayed:

```
A l a r m   C l e a r e d
```

If **Failed** is displayed, check that you have unlocked the emergency stop button.

- 4 On the firefighter gateway LCD, check the main status screen. A message similar to the following should appear:

```
P V   N o r m a l   O p e r a t i o n
0 0 3 / 0 0 3   D e v .   O N
0 0 0 / 0 0 0   D e v .   S a f e
M a x .   V d c :   1 6 4   V
```

- 5 If there is no communication between slave inverters and the master gateway, clear the alarm from the inverter, as follows:
  - a. Enter Setup mode in the inverter LCD menu.
  - b. Select **Maintenance** > **Clear Alarm**.

# Chapter 6: LCD – Status Screens and Setup Options

This chapter describes the LCD display of the SolarEdge firefighter gateway. The LCD screen displays status information of the gateway and various menus for configuration options.

## Status Screens

During normal operation, pressing the Enter button turns the LCD backlight ON. Additional presses on the Enter button display the following screens one after the other. The backlight is active for 30 seconds by default. This duration is configurable, as described on page 32.

### Main Firefighter Gateway Status

This window displays the communication and safety status of components in the system

```
< S t a t u s >
X X X / Y Y Y   D e v .   O N
Z Z Z / Y Y Y   D e v .   S a f e
M a x .   V d c :   0 0 0   V
```

- **Status:** can be one of the following system stages:
  - PV Normal Operation
  - PV Shutting Down – appears when pressing the emergency stop button
  - PV Reducing Voltage - appears during emergency stop
  - PV System Safe – appears when the system reaches 120V after pressing the emergency stop button
  - No Communication – indicates that the slave devices are disconnected from the master
  - Partial Com. – indicates the number of communicating devices (inverters or SMIs) out of the total number of devices in the installation
- **XXX/YYY Dev. ON:** The number of operational inverters or SMIs out of the total number of inverters/SMIs in the installation
- **ZZZ/YYY Dev. Safe:** Number of inverters or SMIs that reached the safety threshold voltage or below, out of the total number of inverters/SMIs in the installation
- **Max. Vdc:** Real-time maximum DC voltage for the entire installation

### ID Status

This window displays the ID of the gateway and the software version.

```
I D :   # # # # # # # #   # #
C P U : 0 0 0 2 . 0 4 1 1
```

### Server Communication Status

```
S e r v e r : L A N   < S _ O K >
S t a t u s :           < O K >
                x x x x x x x x
< E R R O R   M E S S A G E >
```

- **Server:** The method of connection to the SolarEdge monitoring server.
  - LAN
  - RS232

- RS485 (only applicable for slave SolarEdge devices on the RS485 bus)
  - ZigBee (only applicable for slave ZigBee devices)
  - None
- **S\_OK**: The connection to the SolarEdge monitoring portal is successful (appears only if the inverter is connected to the portal).
  - **Status**: Displays OK if the gateway established a successful connection and communication with the specified server port/device (LAN, RS485, ZigBee transceiver or RS232—used for external GSM modem)

If the **OK** status is not displayed, an error has occurred.

- **xxx...**: Eight-bit Ethernet Communication Connection Status: When Ethernet communication is used, an additional row with a string of 1s and optionally 0s is displayed. 1 indicates OK, 0 indicates an error. For a list of possible errors and how to troubleshoot them, refer to *Troubleshooting Ethernet Communication* on page 37. The following is a list of bits description, ordered left-to-right:
  - **Bit 1**: The Ethernet link, physical Ethernet cable connection, WLAN link and GSM connection are all OK.
  - **Bit 2**: The DHCP IP is OK. The IP was successfully obtained from DHCP (if set to static IP=1).
  - **Bit 3**: The ping gateway is OK. The ping to the local switch/router passed or the ping to APN was OK.
  - **Bit 4**: The ping to google.com was OK.
  - **Bit 5**: The ping to server1 was OK.
  - **Bit 6**: The ping to server2 was OK.
  - **Bit 7**: The ping to server3 was OK.
  - **Bit 8**: Communication to the SolarEdge server is OK.
- **Error message**: Refer to *Troubleshooting Ethernet Communication* on page 37.

## IP Status

This window describes the Ethernet configuration: IP, Mask, TCP gateway and MAC address of the gateway.

```

I P      1 9 2 . 1 6 8 . 2 . 1 1 9
M S K    2 5 5 . 2 5 5 . 2 5 5 . 0
G W      1 9 2 . 1 6 8 . 2 . 1
M A C    0 - 2 7 - 0 2 - 0 0 - 3 9 - 3 6
  
```

## ZigBee Status

This window describes the ZigBee configuration:

```

P A N : X X X X X
C H : X X / X X X X   R S S I : < L >
I D :   X X X X X X X X X X X X X X X X
      z i g B e e   R e a d y
  
```

- **PAN**: The ZigBee transceiver pan ID.
- **CH**: The ZigBee transceiver channel
- **RSSI**: The receive signal strength of the neighboring ZigBee transceiver. L = low, M = medium, H = high and - = no signal.
- **ID**: The ZigBee transceiver ID.

- **ZigBee Ready:** This field is shown only in devices with ZigBee router transceivers (slaves), in a multi-point (MP) protocol configuration. If a ZigBee transceiver is not physically connected, a **No ZigBee** message is displayed.

## Communication Ports Status

```

                D e v   P r o t   # #
R S 4 8 5 - 1 < S E > < M > < 0 0 >
R S 4 8 5 - 2 < - - > < - - > < - - >
Z i g B e e < S E > < M P S > < - - >
    
```

This window presents the communication port (RS485-1/2 or ZigBee), and the devices connected to them, with details about the number, type, and protocol.

- **DEV:** The type of device that was configured to the specific port ( based on the port’s functionality), as follows:
  - **SE:** SolarEdge device (default)
  - **---**: None

- **PROT:** The protocol type to which the port is set:
 

For a SolarEdge device:

  - **S:** SolarEdge slave
  - **M:** SolarEdge master
  - **P2P:** ZigBee point-to-point
  - **MPM:** ZigBee multipoint master (for a ZigBee coordinator module)
  - **MPS:** ZigBee multipoint slave (for a ZigBee router module)

For a non-SolarEdge logger:

  - **SS:** SunSpec

For non-SolarEdge inverter readers and revenue meter reader, refer to <http://www.solaredge.com/articles/se-supported-devices>.

- **##:** The total number of slaves detected on the specific port

## Setup Menu Options

This section describes basic gateway configuration options.

- 1 Verify that the SolarEdge gateway is connected to a power outlet.
- 2 Press the **Enter** button until the following message is displayed:

```

P l e a s e   e n t e r
P a s s w o r d
* * * * *
    
```

The gateway is now in Setup mode and all its LEDs are lit. The gateway automatically exits Setup mode if no buttons are pressed for more than 2 minutes.

- 3 Use the three-right-most LCD buttons to type in the following password: **12312312**. The following message is displayed:

```

L a n g u a g e   < e n g >
C o m m u n i c a t i o n
R e m o t e   S h u t d o w n
D i s p l a y
M a i n t e n a n c e
I n f o r m a t i o n
    
```

The following shows a hierarchical tree of the menu options:

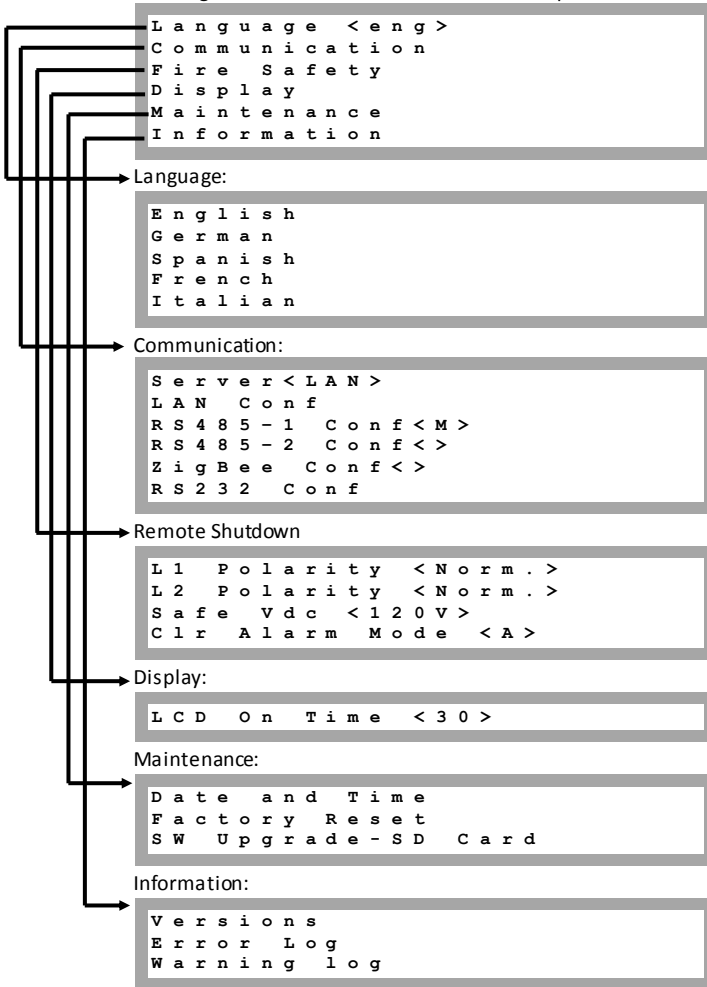

This section describes how to use the LCD menus for configuring the SolarEdge gateway.

## Language

Select the **Language** option to set the language in which the LCD should display. The default setting is English.

## Communication

- 1 Select the **Communication** option to define and configure:
  - The communication option used by the gateway to communicate with the SolarEdge Monitoring portal
  - The communication option used to communicate between multiple SolarEdge devices or other external non-SolarEdge devices, such as revenue meters or loggers.
- 2 Set the communication options as described in *Connecting and Configuring the RS485* on page 18 and *Chapter 7: Setting Up Monitoring through the Firefighter Gateway (Optional)* on page 34.

The following shows a hierarchical tree of the menu options in the **Communication** menu. For detailed information of commonly used the configuration options, refer to the Communication Options application note, available on the SolarEdge website [http://www.solaredge.com/files/pdfs/solaredge-communication\\_options\\_application\\_note\\_v2\\_250\\_and\\_above.pdf](http://www.solaredge.com/files/pdfs/solaredge-communication_options_application_note_v2_250_and_above.pdf).



## Communication:

```

Server < LAN >
LAN Conf
RS 485 - 1 Conf < S >
RS 485 - 2 Conf < >
ZigBee Conf < >
RS 232 Conf

```

## Server:

```

LAN
RS 232
RS 485
Zigbee
None

```

## LAN Conf:

```

IP Config
Set DHCP < en >
Set IP
Set Mask
Set Gateway
Set DNS
Set Server Addr
Set Server Port

```

## RS485-1/2 Conf:

```

Device Type < SE >
Protocol < S >
Device ID < 1 >
Slave Detect < 0 >

```

## ZigBee Conf (enabled only if the ZigBee .module is connected):

```

Device Type < SE >
Protocol < MPS >
Device ID < 1 >
PAN ID
Scan Channel
Load ZB Defaults
Slave Detect < 0 >

```

## RS232 Conf:

```

Device Type < SE >
Protocol < DRCT >

```

## Remote Shutdown

Select **Remote Shutdown** to set the following:

```
L 1 P o l a r i t y < N o r m . >
L 2 P o l a r i t y < N o r m . >
S a f e V d c < 1 2 0 V >
C l r A l a r m M o d e < M >
C l e a r A l a r m
```

- **L1/L2 Polarity:** The lines polarity - Normal (default) or Reverse
- **Safe Vdc:** Threshold value for safe Vdc: When the maximum voltage (of all connected devices) reaches this threshold, the display will show Safe DC in the main gateway status screen. Select either:
  - Safe Vdc. –sets the threshold to the default 120V
  - Setting the threshold in the range between 30 -120V (default 120V)
- **Clr Alarm Mode:** Enables clearing the alarms of emergency stop. Select either:
  - Automatic (default) –when releasing the stop button, the system returns to normal operation
  - Manual - when releasing the stop button, clear the alarm manually (select **Clear Alarm** below) in order to return the system to normal operation
- **Clear Alarm:** Appears only if **Clr Alarm Mode** is set to **Manual** and a stop command has already been sent. After releasing the stop button, select this option to return to normal operation.

For more information, refer to *Chapter 3: Connecting Emergency Stop Button or Fire Alarm Control* on page 14

## Display

Select **Display** to set the following:

```
L C D O n T i m e < 3 0 >
```

- **LCD On Time <30>:** The number of seconds that the LCD backlight is ON after the LCD button is pressed. Set to 0 if you want the LCD to be lit at all times.

## Maintenance

Select **Maintenance** to set the following options :

```
D a t e a n d T i m e
F a c t o r y R e s e t
S W U p g r a d e S D C a r d
```

- **Date and Time:** Set the internal real-time clock. If connected to the SolarEdge monitoring portal, the date and time are set automatically and only time zone should be set.
- **Factory Reset:** Perform a general reset to the gateway default settings.
- **SW Upgrade SD Card:** Perform a software upgrade using an SD card.

## Information

Select **Information** to display the following options:

```
V e r s i o n s  
E r r o r   L o g  
W a r n i n g   l o g
```

- **Versions:** Displays inverter firmware versions :

```
I D :   # # # # # # # # # #  
C P U   : 0 0 0 2 . 0 3 3 6 . 0 0 0 0
```

- **ID:** The SolarEdge gateway ID. 10 last digits of the S/N
- **CPU:** The communication board firmware version.



**NOTE:**

Please have these numbers ready when you contact SolarEdge support.

- **Error Log:** Displays the last five errors.
- **Warning Log:** Displays the last five warnings.

# Chapter 7: Setting Up Monitoring through the Firefighter Gateway (Optional)

## Communication Dataflow

---

The SolarEdge site information can be accessed remotely using the SolarEdge monitoring portal, as described in the *SolarEdge Monitoring Portal User Guide*. In order to transfer monitoring data from a SolarEdge site to the SolarEdge monitoring portal, a communication connection must be set up. Communication setup is not required for power harvesting or for the safety control of the firefighter gateway, however is needed when using the monitoring portal.

This chapter describes how to set up this connection when the gateway is the connection point to the monitoring portal.

The connection point can be any SolarEdge device. If it is the firefighter gateway, the gateway should be the master on an RS485 bus. Otherwise, it should be a slave.

## Communication Types

---

The following types of communication can be used to transfer the monitored information from the inverter to the SolarEdge monitoring portal through the SolarEdge gateway:

- **Ethernet:** Used for a LAN connection
- **RS485:** Enables connection of external devices, such as other SolarEdge inverters, loggers or a revenue gauge meter, and transferring their information through the SolarEdge gateway to the SolarEdge monitoring portal using either a GSM modem or Ethernet. The SolarEdge gateway has two RS485 physical ports:
  - **RS485-1:** Enables connection of multiple SolarEdge devices (inverters/SMIs/gateways) through the same bus to the SolarEdge gateway, such that connecting only one gateway to the server is sufficient to provide communication services for all the devices on the bus.
  - **RS485-2:** Enables connection of third-party devices, such as revenue metering devices, and non-SolarEdge inverters.
- **RS232 (UART):** Used to connect to an external GSM modem (sold separately)
- **ZigBee (optional):** Enables wireless connection of one or more SolarEdge devices through a ZigBee transceiver (sold separately).
- **Mini-USB:** Enables PC/laptop connection for software upgrade using the SolarEdge configuration tool. Use a USB to mini-USB adapter cable for this connection.

## Creating an Ethernet (LAN) Connection

### Overview

This communication option enables using an Ethernet connection to connect the SolarEdge gateway to the SolarEdge monitoring portal through a LAN. The SolarEdge gateway has an RJ45 connector for Ethernet communication.

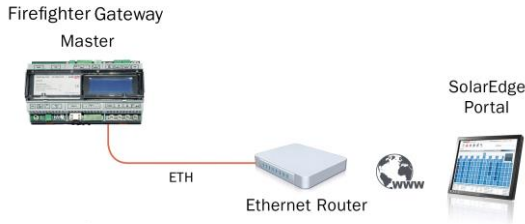

Figure 17: Example of Ethernet Connection

### Ethernet Communication Configuration Options

The following is a description of the options to configure the Ethernet (LAN) port settings.

Communication:

```

Server < LAN >
LAN Conf
RS 485 - 1 Conf < S >
RS 485 - 2 Conf < >
ZigBee Conf < >
RS 232 Conf
  
```

LAN Conf

```

IP Config
Set DHCP < en >
Set IP
Set Mask
Set Gateway
Set DNS
Set Server Addr
Set Server Port
  
```

- IP Config:** Displays the current IP configuration of the gateway, as shown below. If DHCP is used, this screen reflects the parameters retrieved from the DHCP server. If manual settings are used, the screen shows the last manually input configurations.

```

IP      0 . 0 . 0 . 0
MSK     2 5 5 . 2 5 5 . 2 5 5 . 0
GW      1 9 2 . 1 6 8 . 0 . 1
DNS     0 . 0 . 0 . 0
  
```

- Set DHCP <En>:** If the LAN connection between the gateway and the SolarEdge Monitoring Portal has a DHCP server, enable this option by setting it to **Enable** (default). If this option is enabled, then the DHCP server automatically configures the IP, Subnet Mask, gateway and DNS. If not, set them manually.

- **Set IP:** Enables setting the IP of the gateway according to the LAN settings:
  - Use the **Up** and **Down** buttons to adjust the value of each IP address octet.
  - Press the **Enter** button to move to the next IP address octet.
  - Long press the **Enter** button (until **Applied** message appears) – apply the value
  - Long press the **Esc** button (until **Aborted** message appears) – erase all characters

```

Set up IP
1 9 2 . 1 6 8 . 2 . 7
    
```

- **Set Mask:** Set the subnet mask of the SolarEdge gateway according to the LAN settings.
- **Set Gateway:** Set the gateway address of the SolarEdge gateway according to the LAN settings.
- **Set DNS:** Set the DNS of the SolarEdge gateway according to the LAN settings.
- **Set Server Addr:** Set the IP address of the SolarEdge monitoring portal. This option is predefined in the SolarEdge gateway to specify the SolarEdge monitoring portal IP address and does not normally need configuration.
- **Set Server Port:** Set the port through which to connect to the SolarEdge monitoring portal. This option is predefined in the gateway to specify the SolarEdge monitoring portal IP port and normally does not need configuration.



**NOTE:**  
 If your LAN has a firewall, you must verify that the address and port configured in the **Set Server Addr** and the **Set Server Port** fields are not blocked.  
 You may need to configure it to enable the connection to the following address:  
 Destination Address: prod.solaredge.com  
 Port: 22222

## Connecting and Configuring LAN

### ▶ To connect the Ethernet port to the router/switch:

- 1 Use a pre-terminated cable or use a crimper to prepare an RJ45 communication connector on both ends of a standard CAT5/6 cable: Insert the eight wires into the RJ45 connector.

Pin	Wire Color
1	White/green
2	Green
3	White/Orange
4	Blue
5	White/Blue
6	Orange
7	White/Brown
8	Brown

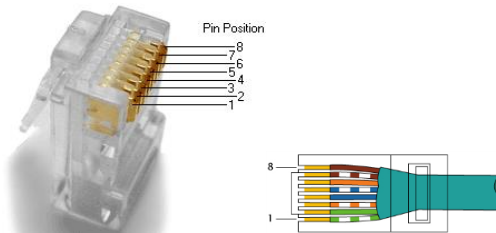

**Figure 18: Inserting Wires into the RJ45 Connector**

- 2 Connect one end of the Ethernet cable to the RJ45 plug at the router or Ethernet gateway that is connected to the Internet.
- 3 Connect the other end to the SolarEdge gateway Ethernet connector.
- 4 Verify that the yellow communication LED turns ON.

**▶ To configure Ethernet communication to the SolarEdge monitoring portal:**

The device connected to the monitoring portal has to be defined as the master device.

The server communication method is configured by default to **LAN with DHCP enabled**. If a **different** setting is required, follow the steps below:

- 1 Enter Setup mode, as described in *Setup Menu Options* on page 28.
- 2 Set the gateway as the master of the RS485 bus and perform slave detection as described in *To configure the RS485 communication bus with SolarEdge inverters/SMI*: on page 21.
- 3 To configure the LAN to Static IP select the following in the LCD menus on the gateway:
  - Communication → Server → LAN
  - LAN Conf → Set DHCP → <Dis>
- 4 Set the IP, mask, gateway DNS, server address, and server port as necessary using the LCD User buttons. Refer to the *Ethernet Communication Configuration Options* on page 35.
- 5 Verify that the status field in the *Server Communication Status* window displays **S\_OK**:

```

Server : LAN          < S _ O K >
Status :             < O K >
```

- 6 Exit the Setup mode.

## Troubleshooting Ethernet Communication

The *Server Communication Status* window can be used to identify errors.

```

Server : LAN          < S _ O K >
Status :             < O K >
                x x x x x x x x
< Error Message >
```

- 1 If **S\_OK** is **not** displayed, use a method independent of the SolarEdge gateway to check whether the network and modem are operating properly. For example, connect a laptop to the Ethernet router and connect to the Internet.
- 2 xxxxxxxx is a string of 1s and 0s showing an eight-bit communication connection status. 1 indicates OK and 0 indicates an error. The possible errors and their troubleshooting are detailed in the following table:

Bit Location	Error Message	Error Description	Troubleshooting
1st	LAN Disconnected	An Ethernet physical cable connection fault: The Ethernet link or physical Ethernet cable are not connected properly	Check the cable pin-out assignment and cable connection
2nd	DHCP Failed, or Invalid DHCP Config	The inverter failed to get a valid IP address from the DHCP server, or The DHCP/static IP settings in the gateway are not the same as those of the router.	Check the router and gateway configuration

Bit Location	Error Message	Error Description	Troubleshooting
3rd	Gateway Ping Failed	The connection to the router is not available: Ping to the first hop switch/router failed (LAN error)	Check the physical connection to the switch/router. Check that the link LED at the router /switch is lit (indicating phy-link). If OK - contact your network IT, otherwise replace the cable or change it from cross to straight connection
4th	G Server Ping Failed	The connection to the Internet is not available: Ping to google.com failed	Connect a laptop and check for internet connection. If internet access is unavailable, contact your IT admin or your internet provider. For WIFI networks, ensure that username and password are as defined in the internet provider AP/router.
5th	Server x Ping Failed	Ping to redundant server #x failed	Check the SolarEdge server address, as described on page 27.
6th			
7th			
8th	Tcp Connect. Failed	The connection to the SolarEdge server was not established: Communication with the server failed	

## Additional Connection Options

### Creating a Wireless ZigBee Connection

This communication option enables using a ZigBee wireless connection for one of the following:

- To wirelessly connect the SolarEdge gateway to other SolarEdge devices (up to 31), and to the monitoring portal through the Ethernet or GSM
- To create a master/slave bus of connected SolarEdge devices

The ZigBee device is provided with a user manual, which should be reviewed prior to connection. It is available on the SolarEdge website at

[http://www.solaredge.com/files/pdfs/se\\_application\\_zigbee\\_communication.pdf](http://www.solaredge.com/files/pdfs/se_application_zigbee_communication.pdf).

### Creating a GSM Connection

This communication option enables connecting the SolarEdge gateway to an external SolarEdge GSM modem. The modem is installed to the RS232 connector of the inverter. The modem is provided with a user manual, which should be reviewed prior to connection. Refer to

[http://www.solaredge.com/files/pdfs/se\\_application\\_gsm.pdf](http://www.solaredge.com/files/pdfs/se_application_gsm.pdf).



## Appendix A: Technical Specifications

Power	Description	Units
Power Supply – DIN Rail	100–240 VAC, EU/UK/US/AU	
Supply Voltage	9-14	Vdc
Connector Type	terminal block	
Power Consumption	<2	W
Communication Interfaces	Type	
Ethernet Interface	10/100-BaseT	
Wireless Connections	ZigBee module <sup>(*)</sup> , GSM <sup>(*)</sup> (**)	
Fire Alarm Control Panel	Alarm input, 5V, GND <sup>(***)</sup>	
SolarEdge Inverters	RS485	
Environmental		
Operating Temperatures	-20 to 60 / -4 to 140	°C / °F
Protection Rating	IP20 Indoor	
Mechanical		
Mounting Type	DIN rail/ Wall mount	
Dimensions (L x W x H)	161.6 x 90 x 62 / 6.36 x 3.54 x 2.44	mm / inch
Weight	0.5 / 1.1	kg / lbs
Standard Compliance		
Safety	UL60950-1, IEC-60950-1	
EMC	FCC Part 15 class B, IEC61000-6-2, IEC61000-6-3	

\* Sold separately. See individual product specifications for supported locations.

\*\* EU only

\*\*\*Emergency stop button is not supplied by SolarEdge

Mechanical specifications:

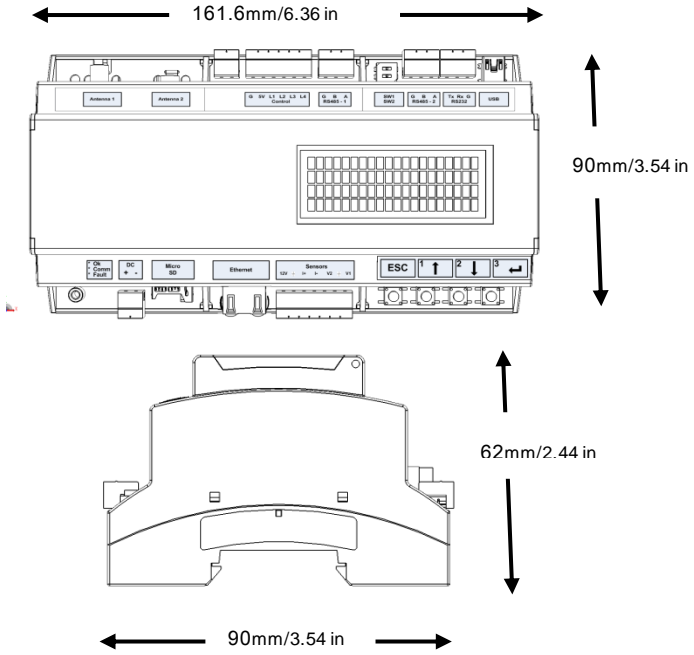

Figure 19: SolarEdge Gateway Mechanical Specifications

If you have technical queries concerning our products, please contact our support through SolarEdge service portal:  
<http://www.solaredge.com/groups/support/services>

North America	(Toll free) 1877 360 529 2
Australia	(Toll free) 1800 149 229
Japan	+ 81 (0) 3 5530 9360
Germany	089 454 597 30
France	(Toll free) 0800 917 410
Italy	(Toll free) 0800 784 824
United Kingdom	(Toll free) 0800 206 105 8
Belgium	(Toll free) 0800 730 41
Israel	073 240 311 8
Rest of world	+ 1 (0) 650 319 884 3
Fax	+ 972 (0) 73 240 311 7
Email to:	<a href="mailto:support@solaredge.com">support@solaredge.com</a>

[www.solaredge.com](http://www.solaredge.com)

**solar**edge  
architects of energy™



MAN-01-00113-1.1