

SCCM10-100

MPPT Charge Controller/Load Manager

Owner's Manual

NOTE:

- Follow instructions in order.
- Charge batteries at least once a week.
- Use reducers to connect larger wires to terminals.

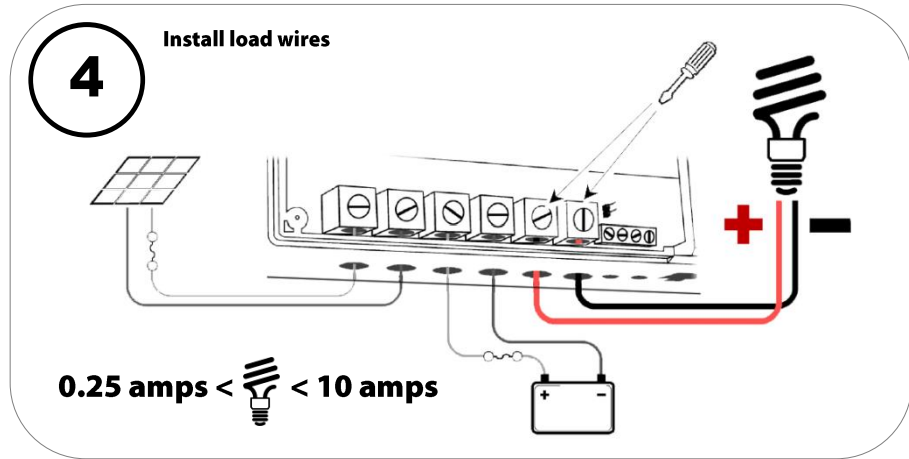
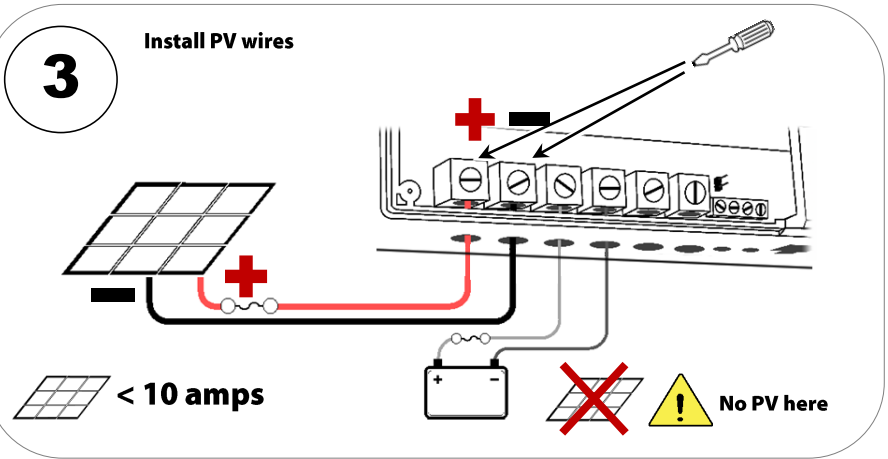
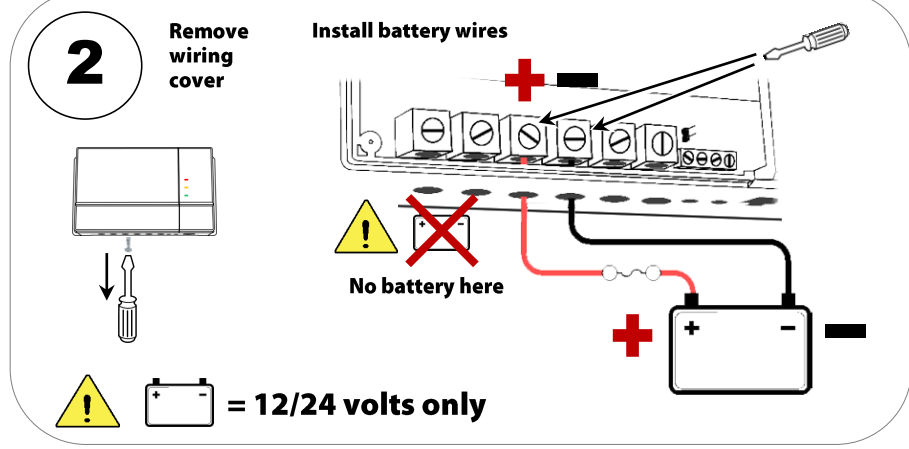
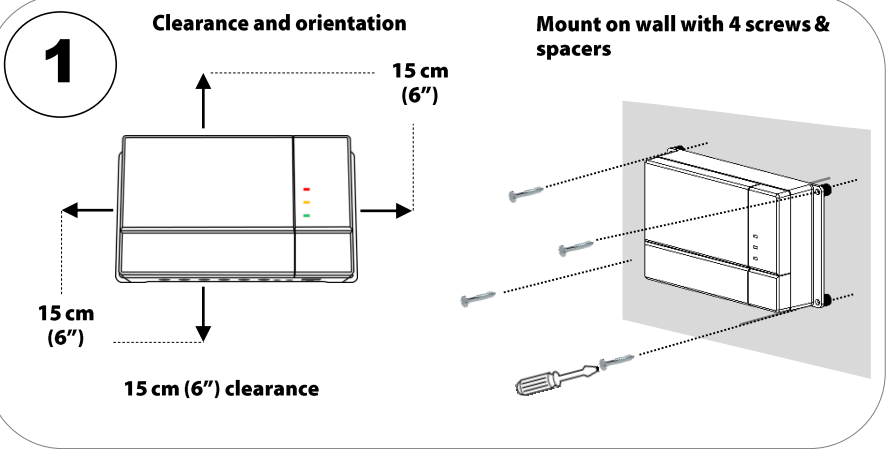
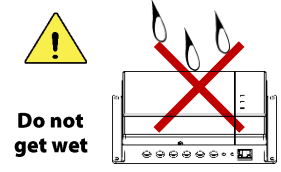
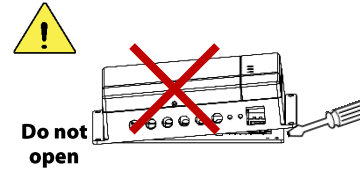
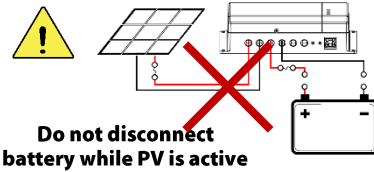

SCCM10-100 Owner's Manual

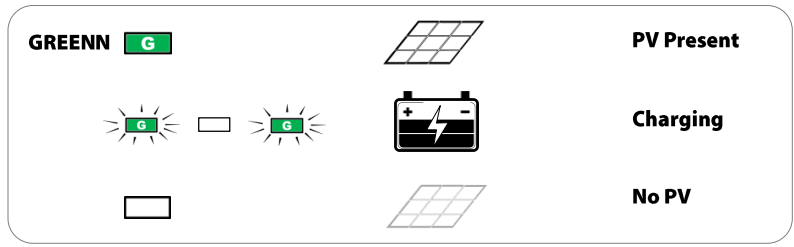
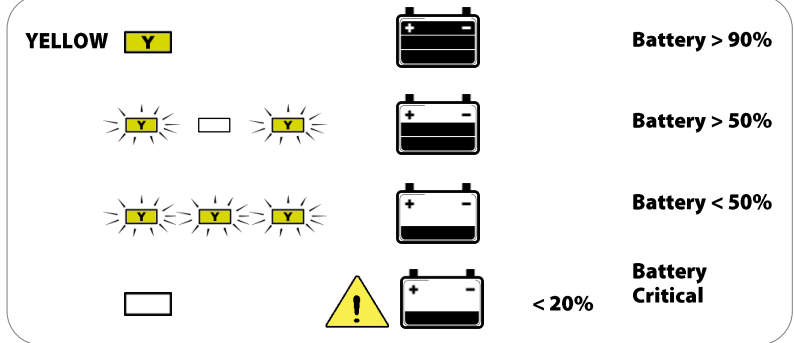
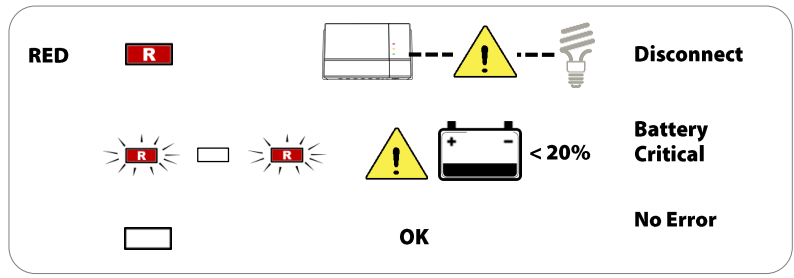
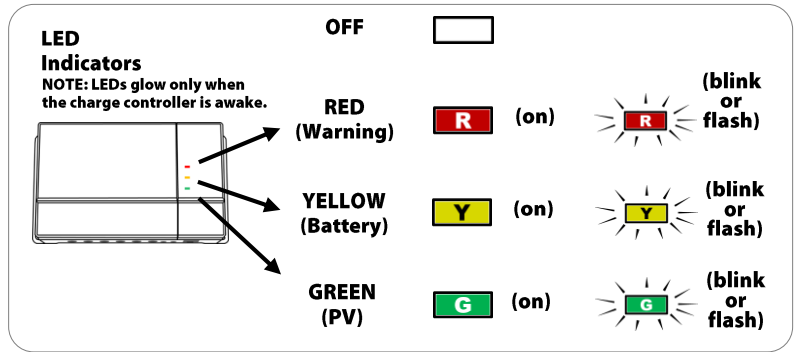
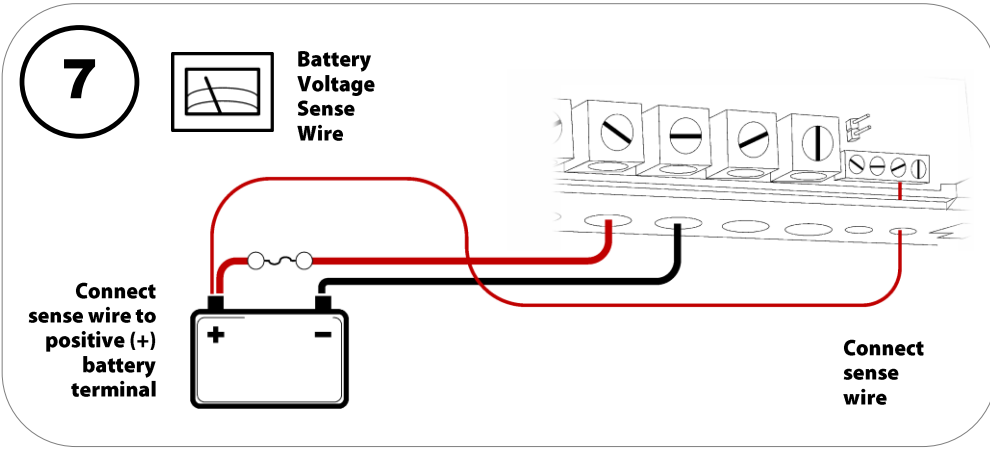
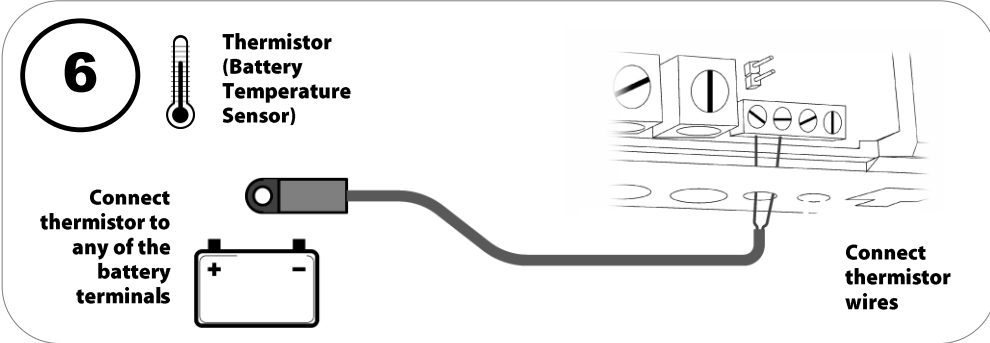
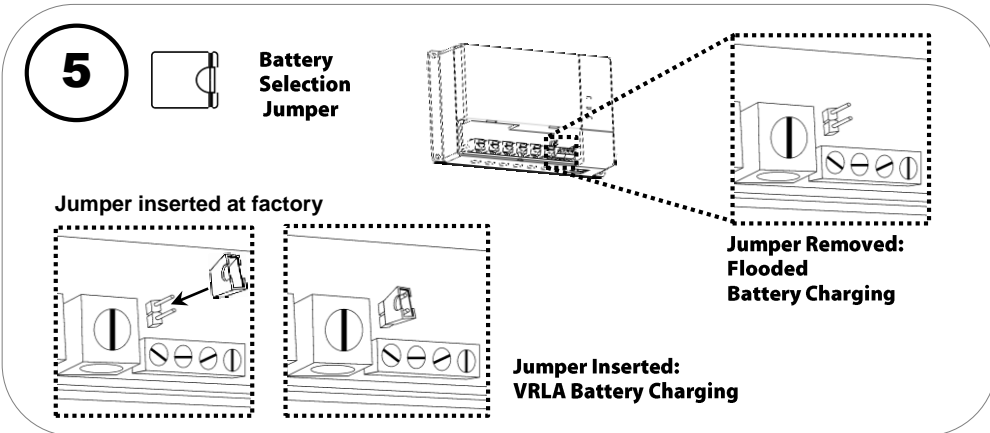

NOTE: Percentages are approximate and are based on battery voltages.

Symbols



Caution: Equipment Damage



Caution: Risk of Electric Shock



Caution: Hot Surface



When disposing, keep this product separate from household waste; recycle this product



Double or Reinforced Insulation; Grounding is unnecessary



Refer to Operating Instructions

Features

1 LED Indicators



2 Compartment Cover Screw



3 PV Input

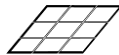

4 Battery Input



5 Load Output



6 Thermistor (Battery Temperature)



7 Battery Voltage Sensing



8 Data Communications

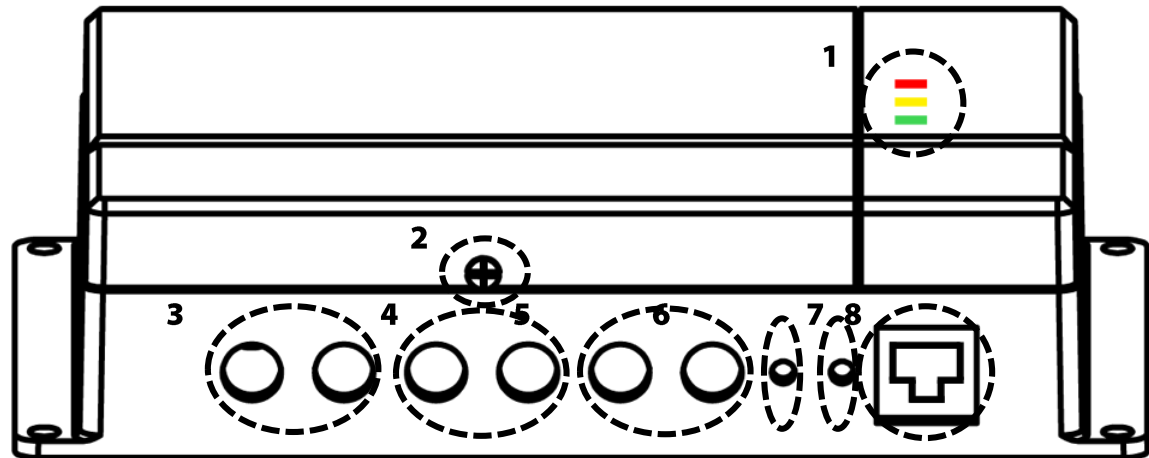

CAUTION: Hazard to Equipment

Proprietary adapter is required.
Do not connect directly to computer or Ethernet.

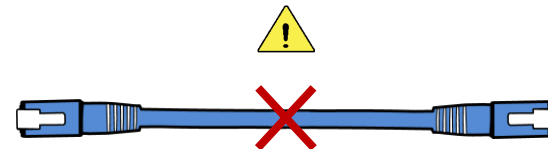
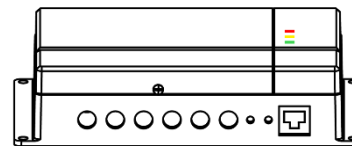

NOTES:

3, 4, and 5: Use flat screwdriver with tip width <6 mm and blade length >50 mm

6 and 7: Use flat screwdriver with tip width <3 mm and blade length >50 mm

SCCM10-100 Owner's Manual

Specifications

Section	Name	12 Vdc		24 Vdc	
PV	Controller Type	MPPT			
	Wattage (maximum)	150 W		300 W	
	V _{oc} (range) NOTE: Will not operate above 85 Vdc	25 to 100 Vdc		40 to 100 Vdc	
	V _{mp} (range)	15 to 70 Vdc		27 to 70 Vdc	
	Short Circuit Current (maximum)	10 Adc			
Battery	Battery Type (jumper-selectable)	Flooded or VRLA			
	Nominal Voltage	12 or 24 Vdc; automatically detected			
	Battery Input (range)	9 to 16 Vdc		18 to 32 Vdc	
	Self-consumption	3 mAdc to 14 mAdc (sleep) and 80 mAdc (awake)			
	Efficiency (maximum)	97%			
Charger	Bulk and Absorption Voltages (maximum) for Battery Types	Flooded	VRLA	Flooded	VRLA
		Bulk	14.8 Vdc*	14.6 Vdc*	29.6 Vdc*
	Absorb	14.8 Vdc*	14.4 Vdc*	29.6 Vdc*	28.8 Vdc*
	Absorb Time	2 hours*			
	Float Voltage	13.2 Vdc*	13.5 Vdc*	26.4 Vdc*	27.0 Vdc*
	Charging Current (maximum)	10 Adc*			
	Temperature Compensation (range)	-5 mV / °C / battery cell*			
	Thermistor	10K NTC			
Equalize	NOTE: Enabled by removing battery jumper; loads turned off while equalizing NOTE*: Occurs every 60 days, or following a low battery load disconnect				
	Equalization Voltage (maximum)	15.5 Vdc*	--	31.0 Vdc*	--
	Equalization Time	1 hour*			

*Number shown is factory default setting. Consult the battery manufacturer for specific charger settings. Item is settable with communications interface.

Section	Name	12 Vdc	24 Vdc
Loads	Minimum Load Size	0.25 Adc	
	Maximum Output Current	10 Adc	
Internal Protections	Internal Protection	Battery Reversal, PV Reversal	
	Load Disconnect (Automatic Reset)	Low Battery, High Battery, Overload	
	Load Disconnect (Manual Reset)	Overload (after 3 automatic resets)	
	Low Battery Load Disconnect	11.4 Vdc*	22.8 Vdc*
	Low Battery Load Reconnect	12.4 Vdc*	24.8 Vdc*
	High Battery Load Disconnect	15.0 Vdc	30.0 Vdc

Dimensions	Size	197 mm (7.8") X 110 mm (4.3") X 45 mm (1.8")	
	Weight	~ 0.5 kg	
Cabling	Terminal Size(PV and battery)	≤32 mm ² (#4 AWG)	
	Cable Size (minimum)	Battery	10 mm ² (#7 AWG)
		PV	6 mm ² (#9 AWG)
	NOTE: Larger cables must be used if battery cables exceed 3 m length NOTE: Battery cables must be twisted together during installation		
	Battery Sense Required Size	0.33 to 0.08 mm ² (#22 to 28 AWG)	
Terminal Torque Value	5.0 Nm (50 in-lb)		
Grounding		Not required	
External Protection (recommended) Follow all local codes to select overcurrent protection.		Battery	≤ 20 Adc, ≥ 100 Vdc
		PV	≤ 10 Adc, ≥ 100 Vdc
Environment	Operating Temperature	-40 °C to 60 °C	
	Humidity	0 to 95% RH non-condensing	
	Ingress Protection	IP20	
Battery Bank	Minimum 50Ah at C/5 discharge rate		
Certifications	CE,EN 61000-6-1,EN 61000-6-3, IEC/EN 62109-1		
Warranty	2 years		

Troubleshooting

Problem	Possible Remedies (perform in order shown)
Battery not charging	1) Check battery connections 2) Check PV voltage and connections 3) Allow charger to cool
No LED indicators with PV power available	1) Check battery voltage at controller terminals 2) Check panel voltage at controller terminals
Red LED on	1) Disconnect PV 2) Disconnect battery 3) Disconnect load 4) Reconnect battery 5) Reconnect PV 6) Reconnect load
Red LED flashing	1) Disconnect loads 2) Charge battery
Yellow LED not on	Charge battery
Charging to wrong voltage	1) Check position of battery selection jumper 2) Check installation of thermistor