

ITEM NO.	PART NUMBER	DESCRIPTION	QTY.
1	2201	CAP SCREW, HEX HEAD, 5/16"-18 X 3/4" UNC-2A, GRADE 8	1
2	1110	QBASE, 1-1/4" ID, FOR 5/16" HARDWARE, A360.1 CAST AL	1
3	2309	LAG SCREW, HEX HEAD, 5/16" X 3", ZINC	2
4	1501	SUBFLASHING, SPUN CONE, QBASE, 9"X9"X.020", 3003 AL, MILL	1
5	1310	FLASHING, SPUN CONE, 18"X18"X.032", 3003 AL, MILL	1
6	2990	COLLAR, COUNTER FLASHING, 1-1/4" ID EPDM	1
7	5316	POST, 1.25" OD X 6.5", 6063-T5, MILL	1
8	2104	WASHER, SEALING, 5/16" ID X 1-1/4" OD, EPDM BONDED SS	1
9	2101	WASHER, FENDER, 5/16" ID X 1" OD, 18-8 SS	1
10	2108	WASHER, SPLIT-LOCK, 5/16" ID, 18-8 SS	1
11	2203	CAP SCREW, HEX HEAD, 5/16"-18 X 1" UNC-2A, 18-8 SS	1

AVAILABLE IN MILL, CLEAR ANODIZED,
AND BRONZE ANODIZED FINISHES.

STAINLESS STEEL LAG SCREWS
INCLUDED WITH ANODIZED FINISHES.

Quick Mount PV

TITLE:
**QMUTM: QBASE UNIVERSAL TILE
MOUNT**

UNLESS OTHERWISE SPECIFIED:

DIMENSIONS ARE IN INCHES
TOLERANCES:
FRACTIONAL $\pm 1/8$
TWO PLACE DECIMAL $\pm .18$
THREE PLACE DECIMAL $\pm .125$

SIZE A	DRAWN BY: RAD	REV 6
	DATE: 10/1/2013	
SCALE: 1:8	WEIGHT: 2.26	SHEET 1 OF 2

PROPRIETARY AND CONFIDENTIAL
THE INFORMATION CONTAINED IN THIS DRAWING IS THE SOLE PROPERTY OF QUICK MOUNT PV. ANY REPRODUCTION IN PART OR AS
A WHOLE WITHOUT THE WRITTEN PERMISSION OF QUICK MOUNT PV IS PROHIBITED.

DO NOT SCALE DRAWING

5

4

3

2

1

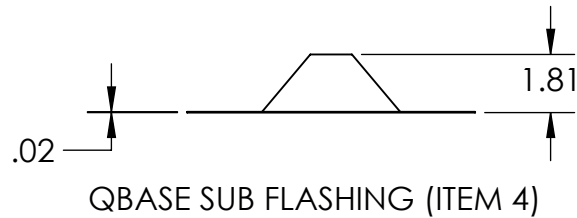
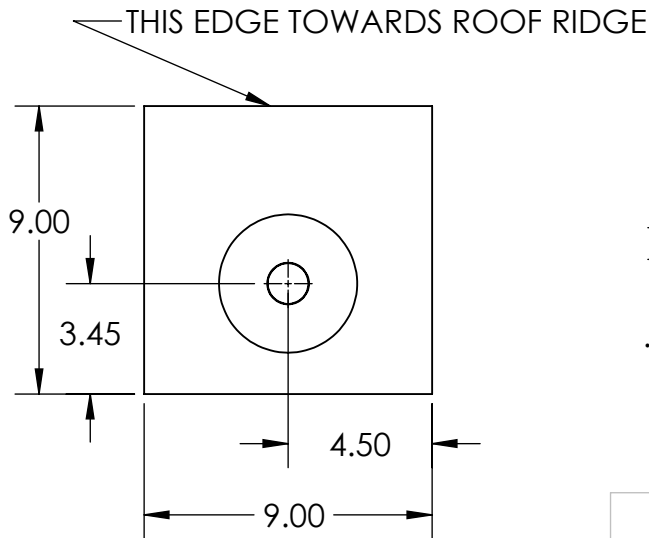
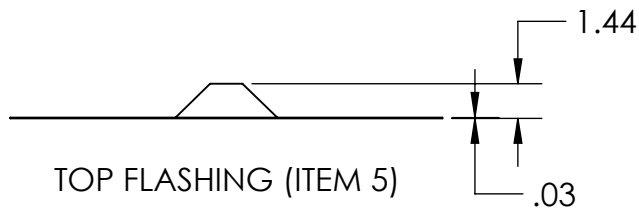
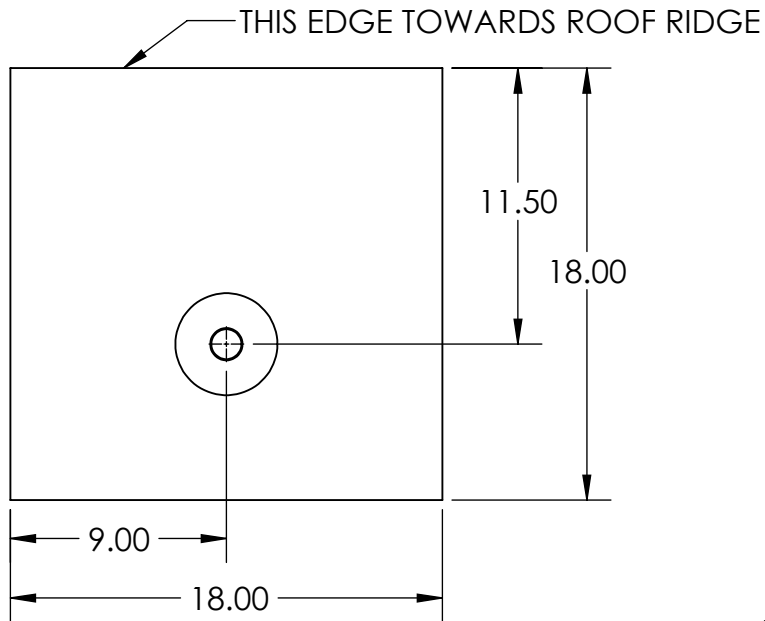

QBASE SUB FLASHING (ITEM 4)

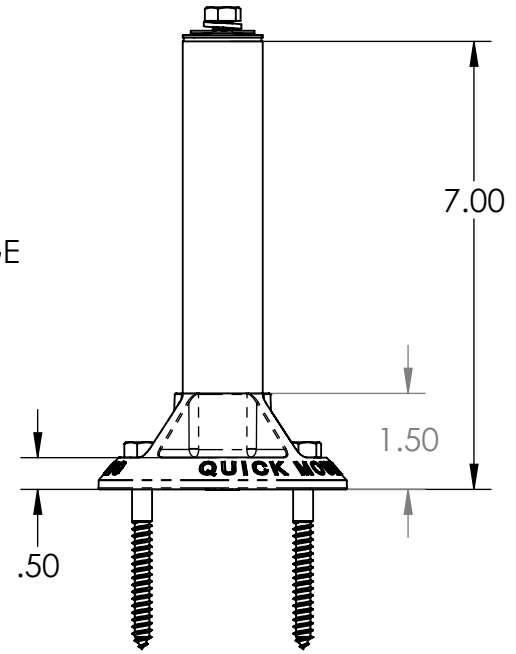
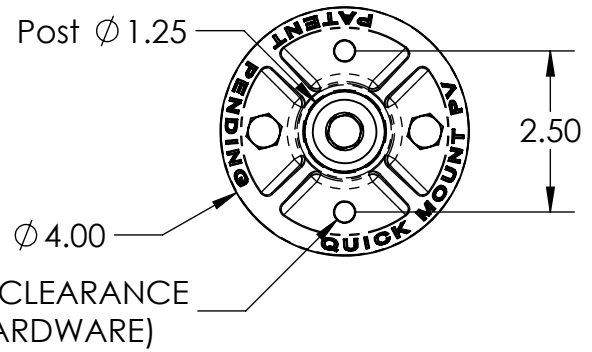

QBASE (ITEM 2) AND POST (ITEM 7)

Quick Mount PV[®]

TITLE:
QMUTM: QBASE UNIVERSAL TILE MOUNT

UNLESS OTHERWISE SPECIFIED:
DIMENSIONS ARE IN INCHES
TOLERANCES:
FRACTIONAL $\pm 1/8$
TWO PLACE DECIMAL $\pm .18$
THREE PLACE DECIMAL $\pm .125$

SIZE A	DRAWN BY: RAD	REV 6
	DATE: 10/1/2013	
SCALE: 1:8	WEIGHT: 2.26	SHEET 2 OF 2