

POWER RAIL™
Top-Clamping PV Mounting System
P6, P8 and P14 Rails

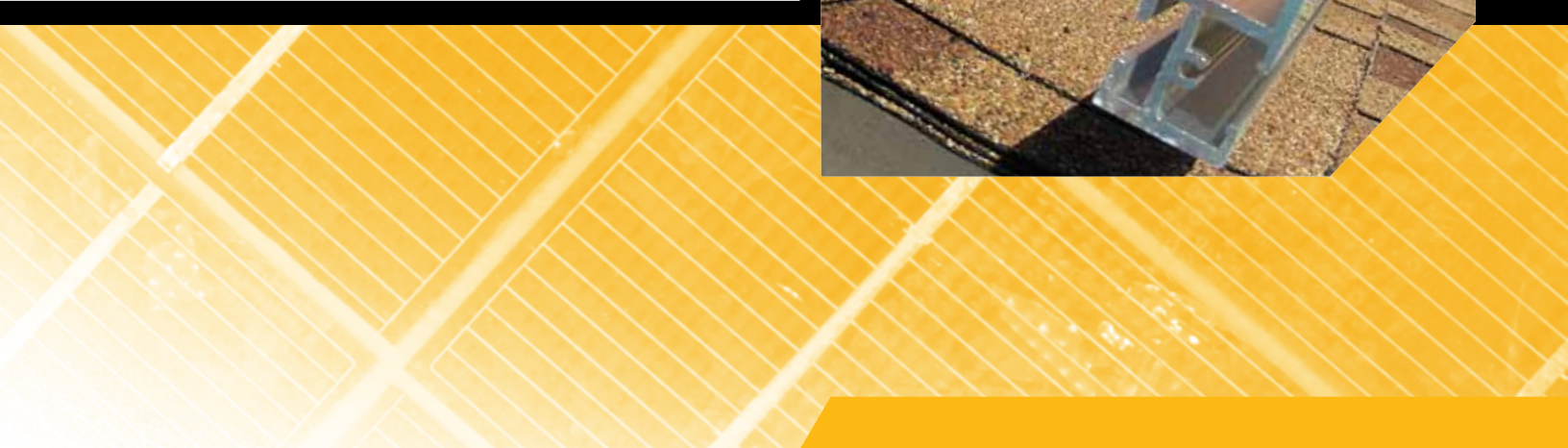

-  COMMUNICATIONS
-  ENERGY
-  SPECIAL INDUSTRIES
-  SOLAR

Quality Hardware for the PV Industry



Power Rail™ Roof Mounting System

The top-clamping PV module mounting system is engineered to reduce installation costs and provide maximum strength for parallel-to-roof or tilt up mounting applications.



Cable Management in Rails

The Power Rail top-clamping mounting system is designed with the professional PV solar installer in mind. The top-clamping rails utilize a single tool with a revolutionary RAD™ Fastener for faster bolt placement. The unique shape of the RAD provides an anti-rotation feature, locking the bolt in the proper orientation when installed. The high

strength rigid rails also include an integral wiring channel for securing cables and providing a professional finish. The Power Rail Mounting System features the industry's broadest selection of mounting supports, designed for secure and water tight attachments to any roof style.



Flashed Supports

Mounting Rail Options

- P6-Rail** Engineered to save cost on shorter span applications
- P8-Rail** Engineered for longer span and heavier snow conditions
- P14-Rail** Engineered for commercial applications with greater distances between supports

* Reference Rail Span and Cantilever Charts on the back of this sell sheet.

Features

High Strength Reliable Design

- Engineered rail profiles for maximum strength-to-weight ratio
- Structural Aluminum rigid rail construction
- High Strength stainless steel module clamps and hardware

Flexible Mounting Options

- Height adjustable "L" mounting feet
- Tilt Feet up to 10 degrees
- Solid Aluminum Power Post™ stanchions
- Easy Feet™ attachment anywhere on metal or composite roof decking
- PV Flashing mounting supports
- Telescoping and One-Piece Tilt Kits up to 65 degrees
- Easy Feet Tile Hooks



Easy Feet™, Power Post™ and "L" Feet Supports

Reduced Installation Time and Costs

- Single Tool Assembly – all 5/16" hardware
- RAD Fastener for quick bolt placements anywhere along rail
- Under flange clamping options
- Integral Wiring Channel for securing cables
- Standard lengths up to 27 feet eliminate costly rail splices
- Snap-In WEEB Integral module grounding option



Tilt-up applications

Power Rail™ Roof Mounting System



Standard Rail Lengths

P6 Part #	P8 Part #	P14 Part #	Length
P6-84	P8-84	P14-84	84"
P6-126	P8-126	P14-126	126"
P6-162	P8-162	P14-162	162"
P6-204	P8-204	P14-204	204"
P6-240	P8-240	P14-240	240"
P6-282	P8-282	P14-282	282"
P6-324	P8-324	P14-324	324"



P14

P8

P6

Power Rail Extrusions



Lock-In-Place RAD Bolt

Mid Clamp with Revolutionary RAD™ Fastener

- Twist in anywhere along rail channel – avoid sliding bolts
- Visual indicator of bolt orientation
- “D” hole on mating clamp locks bolt from rotating
- Tight 3/8” module spacing
- High strength stainless steel clamp and bolt



Lock-In-Place RAD™ Fastener – Patent Pending



Universal End Clamp

- Simply slides under rail and clamps module flange
- Secures any framed PV module
- Improved aesthetics allows module frame to be placed flush with rail end
- High strength stainless steel construction

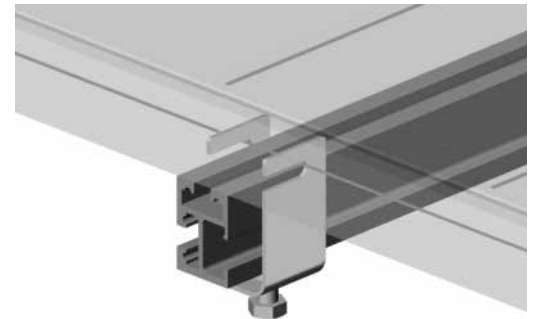

P6 Universal End Clamp

Refer to the Power Rail Catalog at www.dpwsolar.com for all roof attachments and clamping options.

Wind and Snow Loading Capability

P6 Rail – Span/Cantilever Distances (inches)

	SPAN/C'VER	SNOW LOAD (PSF)										
		0	10	20	30	40	50	60	70	80	90	100
WIND SPEED* (MPH)	90	72/36	60/32	54/26	48/24	43/21	40/20	36/18	33/16	31/15	29/14	28/14
	100	60/32	58/28	48/24	46/23	42/21	38/19	36/18	33/16	31/15	29/14	28/14
	110	58/28	54/26	48/24	44/22	40/20	37/18	35/17	33/16	31/15	29/14	28/14
	120	54/26	54/26	46/23	42/21	39/19	36/18	34/17	32/16	31/15	29/14	28/14
	130	48/24	48/24	44/22	40/20	37/18	35/17	33/16	32/16	30/15	29/14	28/14

P8 Rail – Span/Cantilever Distances (inches)

	SPAN/C'VER	SNOW LOAD (PSF)										
		0	10	20	30	40	50	60	70	80	90	100
WIND SPEED* (MPH)	90	96/48	92/46	80/40	72/36	66/33	62/31	58/29	52/26	50/25	46/23	44/22
	100	88/44	86/43	76/38	68/34	64/32	60/30	56/28	52/26	50/25	46/23	44/22
	110	80/40	80/40	72/36	66/33	62/31	58/29	54/27	52/26	50/25	46/23	44/22
	120	74/37	74/37	68/34	64/32	60/30	56/28	52/26	50/25	48/24	46/23	44/22
	130	68/34	68/34	66/33	60/30	56/28	54/27	52/26	48/24	46/23	44/22	44/22
	140	64/32	64/32	62/31	58/29	54/27	52/26	50/25	48/24	46/23	44/22	42/21
	150	60/30	60/30	60/30	56/28	52/26	50/25	48/24	46/23	44/22	42/21	42/21

P14 Rail – Span/Cantilever Distances (inches)

	SPAN/C'VER	SNOW LOAD (PSF)										
		0	10	20	30	40	50	60	70	80	90	100
WIND SPEED* (MPH)	90	168/79	160/75	141/66	128/60	118/55	110/52	103/48	96/45	90/42	85/40	81/38
	100	153/72	150/71	134/63	123/58	113/53	106/50	100/47	95/45	90/42	85/40	81/38
	110	140/66	140/66	127/60	117/55	109/51	103/48	97/46	92/43	88/41	85/40	81/38
	120	129/61	129/61	121/57	112/53	105/49	99/47	94/44	90/42	86/40	83/39	80/38
	130	120/56	120/56	115/54	107/50	101/47	96/45	91/43	87/41	84/39	81/38	78/37
	140	112/53	112/53	109/51	103/48	97/46	93/44	88/41	85/40	82/39	79/37	76/36
	150	105/49	105/49	104/49	99/47	94/44	89/42	86/40	82/39	79/37	77/36	74/35

*Exposure C Category, please refer to design guidelines and ASCE requirements for more information.



4000-B Vassar Drive NE
Albuquerque, New Mexico 87107
USA

Telephone: 800.260.3792
Fax: 505.889.3548
Web Site: www.DPWSolar.com
E-mail: info@power-fab.com

Preformed Line Products
(Canada) Limited
1711 Bishop St. E
Cambridge, ON N1T 1N5

Telephone: 519-740-6666
Fax: 519-740-7917
Web site: www.preformed.on.ca
Email: sales@preformed.on.ca



YOUR DPW SOLAR DISTRIBUTOR
SOLARIS
720-474-6050
www.solaris-shop.com