

ABB solar inverters

Product manual

MICRO-0.25/0.3/0.3HV-I-OUTD-US-208/240





IMPORTANT SAFETY INSTRUCTIONS

This manual contains important safety instructions that must be followed during installation and maintenance of the inverter.



SAVE THESE INSTRUCTIONS!

Keep this document in a safe place near the inverter for easy access during installation and maintenance.



THE INSTALLER MUST READ THIS DOCUMENT IN ITS ENTIRETY BEFORE INSTALLING OR COMMISSIONING THIS EQUIPMENT.

The purpose of this document is to support the qualified technician, who has received training and/or has demonstrated skills and knowledge in construction, to install and maintain this inverter. This manual does not cover any details concerning equipment connected to the inverter such as the solar modules. Information concerning the connected equipment is available from the respective manufacturers.

Warranty conditions can be found on the MICRO product page of the website. NOTE: Any changes or modifications not approved by the responsible party could void the user authority to operate the equipment.

FCC REMARKS



The equipment has been tested and found to comply with the limits for a Class B digital device, pursuant to Part 15 of the FCC Rules. These limits are designed to provide reasonable protection against harmful interference in a residential installation. This equipment generates, uses and can radiate radio frequency energy and, if not installed and used in accordance with the instructions, may cause harmful interference to radio communications.

However, there is no guarantee that interference will not occur in a particular installation. If this equipment does cause harmful interference to radio or television reception, which can be determined by turning the equipment off and on, the user is encouraged to try to correct the interference by one or more of the following measures:

- *Reorient or relocate the receiving antenna.*
- *Increase the separation between the equipment and receiver.*
- *Connect the equipment into an outlet on a circuit different from that to which the receiver is connected.*
- *Consult the dealer or an experienced radio/TV technician for help.*

Product Manual

MICRO inverter

1 - Introduction and safety



2 - Installation location



3 - Mounting and wiring



4 - Operations



5 - Troubleshooting



6 - Maintenance



7 - Appendix



Contents

Introduction and safety	7
Warnings in this document	7
Equipment safety warnings	7
General installation warnings.....	8
Electrical connection warnings.....	8
Safety instructions	8
Thermal and voltage hazard	9
Location of safety notices and labels.....	9
Appropriate usage.....	9
Improper or prohibited use.....	9
Available models	10
Regulatory label	10
Product identification label.....	12
Installation location	13
Transportation and handling.....	13
Incoming inspection.....	13
Overall dimensions and minimum clearances.....	14
Environmental check of installation location.....	14
Installation position.....	15
Choice of AC cable	16
Mounting and wiring	19
Assembly diagram.....	19
Assembly instructions	20
DC grounding electrode conductor coupling all the MICRO inverters	21
DC grounding electrode conductors for each MICRO inverter	22
Installing the AC trunk end cap.....	26
Use of the AC trunk unlock tool	26
Wiring details	27
Load protection switch (AC disconnect switch)	27
Differential protection downstream of the inverter.....	28
Choosing the interface protection system and device downstream of the inverter ..	28
AC grid connections	28
Characteristics and sizing of the line cable.....	29
Wiring of AC cable	29
Operations	31
Commissioning.....	31
Sequence of operations	31
LED indicators.....	32

T	<i>Troubleshooting</i>	33
	Alarm messages generated by the MICRO inverter	33
	Verification of ground leakage	38
	Behavior of a system without leakage	38
	Behavior of a system with leakage	39
	Measuring the insulation resistance of the PV module	39
	Making a service call.....	40
M	<i>Maintenance</i>	41
	Routine maintenance	41
	Storage and dismantling	42
A	<i>Appendix</i>	43
	The MICRO inverter system	43
	Characteristics of MICRO inverters	43
	Functionality of the equipment	44
	Protective devices	44
	Efficiency curves	45
	Power reduction curves.....	46
	Block diagram.....	49
	Wiring diagram – 208Vac three phase.....	50
	Wiring diagram – 240Vac split phase.....	51
	Template for system diagram of installation.....	52
	Technical data and types	53

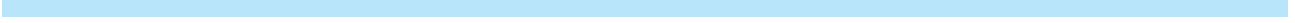





Introduction and safety

1





Warnings in this document

This is a list of special safety symbols used in this manual that highlight potential safety risks and/or useful information. The symbol usage is described below:

	CAUTION The reader should stop, use caution and fully understand the operations explained before proceeding.
	DANGEROUS VOLTAGE The product works with high voltages. All work on the inverter must follow the described documentation and must comply with all prevailing codes and regulations associated with high voltages.
	HOT TEMPERATURE Some surfaces may become hot; do not touch the product while it is in operation.
	UL1741 Standard for Safety for Inverters, Converters, Controllers and Interconnection System Equipment for use with Distributed Energy Resources. CSA-C22.2 No. 107.1-01 - General Use Power Supplies.

Equipment safety warnings

In addition to the safety and hazard symbols, the following symbols are also used in this installation guide.

	System earth conductor (equipment ground, protective earth)
	Alternating current (AC)
	Direct current (DC)
	Phase
	Grounding (earth)

General installation warnings

The inverter is designed and tested according to international safety requirements (UL1741/IEEE1547); however, certain safety precautions must be observed when installing and operating this inverter. Read and follow all instructions, cautions and warnings in this installation manual.



It is required that the CDD be installed with any MICRO inverter in compliance with UL1741, for the purpose of indication and resetting of ground faults. The wireless communication system inside the MICRO transmits information to the CDD that analyzes and manages data. See CDD product manual and/or Quick Installation Guide, available on the website, for a description of the CDD.

Electrical connection warnings

This grid-tied inverter system operates only when properly connected to the AC utility grid. Before connecting the grid-tied inverter to the AC utility grid, contact the local power distribution company to receive the appropriate approvals. This connection must be made only by qualified technical personnel.



Wiring methods used should be in accordance with the National Electric Code, ANSI/NFPA 70 and/or any prevailing local codes and regulations.

The AC output (neutral) is not bonded to ground. The input and output circuits are isolated from the enclosure and the system grounding must be installed per the requirements of the National Electric Code, ANSI/NFPA 70, and is the responsibility of the installer



It is the responsibility of the installer to provide external disconnect switches and Overcurrent Protection Devices (OCPD) as required by National Electric Codes and other prevailing regulations.

To reduce the risk of fire, connect only to a circuit provided with 20A maximum branch circuit overcurrent protection in accordance with the National Electric Code (ANSI/NFPA 70).

Safety instructions



Normally grounded conductors may be ungrounded and energized when a ground-fault is indicated resulting in risk of electric shock. Always test voltage with a voltmeter before touching.

Install the inverter in accordance with the electrical standards prescribed by the applicable National Electric Code (NEC), and/or by other local codes and regulations.

Thermal and voltage hazard



Certain parts may be extremely hot immediately following shut down due to normal elevated surface temperatures (e.g. transformers, accumulators, coils etc.).

Prior to touching any part of the inverter use care to ensure surfaces and equipment are at touch-safe temperatures and voltages before proceeding.



Anytime the inverter has been disconnected from the AC utility grid, use extreme caution as some components can retain charge sufficient to create a shock hazard and may need time to dissipate the charge. To minimize occurrence of such conditions, comply with all corresponding safety symbols and markings present on the unit and in this manual.

Location of safety notices and labels

Note the location of safety notices on the MICRO inverter. Labels must not be hidden with external objects or parts such as rags, boxes, or other such equipment. They should be cleaned periodically and always maintained in view. Technical data in this manual does not supersede the data on the labels affixed to the equipment

<p>⚠ CAUTION! Risk of electric shock. Do not remove the cover. No user serviceable parts inside. Refer servicing to qualified service personnel. Risk of electric shock. Both AC and DC voltage sources are terminated inside this equipment. Each circuit must be individually disconnected and the service person must wait 5 minutes before servicing. Risk of electric shock from energy stored in capacitors. When the photovoltaic array is exposed to light, it supplies a DC voltage to this equipment.</p>	<p>⚠ WARNING! Integral DC Ground Fault Detector/Interrupter Protection is assembled. Electric shock hazard. Normally grounded conductors of the photovoltaic power system may be ungrounded and energized when a ground fault is indicated.</p>	<p>⚠ CAUTION! Hot surfaces. To reduce the risk of burns. Do not touch.</p>
--	--	---

Appropriate usage

The MICRO inverter is designed to transform direct current (DC) coming from a photovoltaic module (PV) into an alternating current (AC) suitable for being fed into the power distribution grid.

- The operating current output during the normal operation MUST NOT exceed the limits documented in the technical specifications.
- Only one photovoltaic module can be connected in the input of the inverter (DO NOT connect batteries or other sources of power supply).
- Adverse environmental condition, such as: sun, rain, snow, wind, too hot or too cold, altitudes, humidity, etc., can lead to a reduction in performance.

Improper or prohibited use

The following actions are dangerous and not consistent with acceptable practice under the terms of the warranty:

- Installing the equipment in environments with flammable conditions or in adverse/constrained environmental conditions (temperature and humidity).
- Using the equipment with safety devices not working or disabled.
- Using the equipment or parts of the equipment by connecting it to other machines or equipment, unless otherwise expressed.
- Cleaning with corrosive products that may corrode parts of the equipment or with products that might generate electrostatic charges.

Available models

There are three models of the MICRO, defined by their rated output power (0.25 kW , 0.3 kW, or 0.3kW high voltage (HV)). Each version is also available for either a 240Vac split phase or 208Vac single phase AC grid connection. All model dimensions are 10.5" x 9.7" x 1.37" and weigh 3-1/2 lb (1.65kg).



Output power	Model number
250 Watts	MICRO-0.25-I-OUTD-US-208/240
300 Watts	MICRO-0.3-I-OUTD-US-208/240
300 Watts	MICRO-0.3HV-I-OUTD-US-208/240

Regulatory label

The label shown is affixed to the inverter and provides the following information:

<p>Made in China</p> <p>259813 C 259813 US CSA C22.2 No. 107.1-01 UL 1741</p> <p>www.abb.com/solar SOLAR GRID TIED INVERTER UTILITY INTERACTIVE MODEL: MICRO-0.3HV-I-OUTD-US-208/240</p>	<p>DC RATING</p> <table border="1"> <tr><td>Nominal Input Operating Voltage</td><td>45 V ===</td></tr> <tr><td>Max. Input Voltage</td><td>79 V === (1)</td></tr> <tr><td>Range of Input Operating Voltage</td><td>19 - 75 V === (1)</td></tr> <tr><td>Range of Input Voltage @Full Power</td><td>30 - 75 V === (1)</td></tr> <tr><td>Max. Input Current</td><td>10.5 A (1)</td></tr> <tr><td>Max. Input Short Circuit Current (P.V. Panels)</td><td>12.5 A (1)</td></tr> </table> <p>(1): For More Details Refer to the Instructions Manual</p>	Nominal Input Operating Voltage	45 V ===	Max. Input Voltage	79 V === (1)	Range of Input Operating Voltage	19 - 75 V === (1)	Range of Input Voltage @Full Power	30 - 75 V === (1)	Max. Input Current	10.5 A (1)	Max. Input Short Circuit Current (P.V. Panels)	12.5 A (1)	<p>AC RATING</p> <table border="1"> <tr><td>Nominal Output Voltage</td><td>208 V- / 2W - 1Ø 240 V- / 3W - SPØ</td></tr> <tr><td>Operating Voltage Range</td><td>183 - 228V- / 211 - 264V-</td></tr> <tr><td>Nominal Output Frequency</td><td>60 Hz (factory preset)</td></tr> <tr><td>Operating Frequency Range</td><td>57 to 59.6 (adjustable) - 60.5 Hz</td></tr> <tr><td>Output Power Factor</td><td>> 0.95</td></tr> <tr><td>Max. Output Current</td><td>1.44 A (rms@208V- / 1.25 A (rms@240V-)</td></tr> <tr><td>Max. Continuous Output Power</td><td>300 W @ 65°C amb.</td></tr> <tr><td>Max. Output Overcurrent Protection</td><td>20 A</td></tr> </table>	Nominal Output Voltage	208 V- / 2W - 1Ø 240 V- / 3W - SPØ	Operating Voltage Range	183 - 228V- / 211 - 264V-	Nominal Output Frequency	60 Hz (factory preset)	Operating Frequency Range	57 to 59.6 (adjustable) - 60.5 Hz	Output Power Factor	> 0.95	Max. Output Current	1.44 A (rms@208V- / 1.25 A (rms@240V-)	Max. Continuous Output Power	300 W @ 65°C amb.	Max. Output Overcurrent Protection	20 A	<p>Operating Ambient Temperature: -40 to +75 °C (-40 to +167 °F), with Output Power Derating (1) Type of Enclosure: NEMA 4X DC Ground Fault Detector/Interrupter is Provided (1): For More Details Refer to the Instructions Manual</p> <p>Contains FCC ID: X619-EM8Z This device complies with part 15 of the FCC Rules. Operation is subject to the following two conditions: (1) This device may not cause harmful interference and (2) this device must accept any interference received, including interference that may cause undesired operation.</p>	<p>SERIAL NUMBER: 3L03021F400 000013012</p> <p>MAC ADDRESS: AA:BB:CC:DD:EE:FF:GG:HH</p>
	Nominal Input Operating Voltage	45 V ===																														
Max. Input Voltage	79 V === (1)																															
Range of Input Operating Voltage	19 - 75 V === (1)																															
Range of Input Voltage @Full Power	30 - 75 V === (1)																															
Max. Input Current	10.5 A (1)																															
Max. Input Short Circuit Current (P.V. Panels)	12.5 A (1)																															
Nominal Output Voltage	208 V- / 2W - 1Ø 240 V- / 3W - SPØ																															
Operating Voltage Range	183 - 228V- / 211 - 264V-																															
Nominal Output Frequency	60 Hz (factory preset)																															
Operating Frequency Range	57 to 59.6 (adjustable) - 60.5 Hz																															
Output Power Factor	> 0.95																															
Max. Output Current	1.44 A (rms@208V- / 1.25 A (rms@240V-)																															
Max. Continuous Output Power	300 W @ 65°C amb.																															
Max. Output Overcurrent Protection	20 A																															

<p>1. Certification 2. Product origin 3. Model number</p>	<p>Made in China</p> <p>259813 C 259813 US CSA C22.2 No. 107.1-01 UL 1741</p> <p>www.abb.com/solar SOLAR GRID TIED INVERTER UTILITY INTERACTIVE MODEL: MICRO-0.3HV-I-OUTD-US-208/240</p>														
<p>4. DC input ratings</p>	<table border="1"> <thead> <tr> <th colspan="2">DC RATING</th> </tr> </thead> <tbody> <tr><td>Nominal Input Operating Voltage</td><td>45 V ===</td></tr> <tr><td>Max. Input Voltage</td><td>79 V === (1)</td></tr> <tr><td>Range of Input Operating Voltage</td><td>19 - 75 V === (1)</td></tr> <tr><td>Range of Input Voltage @Full Power</td><td>30 - 75 V === (1)</td></tr> <tr><td>Max. Input Current</td><td>10.5 A (1)</td></tr> <tr><td>Max. Input Short Circuit Current (P.V. Panels)</td><td>12.5 A (1)</td></tr> </tbody> </table> <p>(1): For More Details Refer to the Instructions Manual</p>	DC RATING		Nominal Input Operating Voltage	45 V ===	Max. Input Voltage	79 V === (1)	Range of Input Operating Voltage	19 - 75 V === (1)	Range of Input Voltage @Full Power	30 - 75 V === (1)	Max. Input Current	10.5 A (1)	Max. Input Short Circuit Current (P.V. Panels)	12.5 A (1)
DC RATING															
Nominal Input Operating Voltage	45 V ===														
Max. Input Voltage	79 V === (1)														
Range of Input Operating Voltage	19 - 75 V === (1)														
Range of Input Voltage @Full Power	30 - 75 V === (1)														
Max. Input Current	10.5 A (1)														
Max. Input Short Circuit Current (P.V. Panels)	12.5 A (1)														



<p>5. AC output ratings</p>	<table border="1"> <thead> <tr> <th colspan="2" style="text-align: center;">5 AC RATING</th> </tr> </thead> <tbody> <tr> <td>Nominal Output Voltage</td> <td>208 V~ / 2W - 1Ø 240 V~ / 3W - SPØ</td> </tr> <tr> <td>Operating Voltage Range</td> <td>183 - 228V~ / 211 - 264V~</td> </tr> <tr> <td>Nominal Output Frequency</td> <td>60 Hz (factory preset)</td> </tr> <tr> <td>Operating Frequency Range</td> <td>57 to 59.8 (Adjustable) - 60.5 Hz</td> </tr> <tr> <td>Output Power Factor</td> <td>> 0.95</td> </tr> <tr> <td>Max. Output Current</td> <td>1.44 A (rms)@208V~ / 1.25 A (rms)@240V~</td> </tr> <tr> <td>Max. Continuous Output Power</td> <td>300 W @ 65°C amb.</td> </tr> <tr> <td>Max. Output Overcurrent Protection</td> <td>20 A</td> </tr> </tbody> </table>	5 AC RATING		Nominal Output Voltage	208 V~ / 2W - 1Ø 240 V~ / 3W - SPØ	Operating Voltage Range	183 - 228V~ / 211 - 264V~	Nominal Output Frequency	60 Hz (factory preset)	Operating Frequency Range	57 to 59.8 (Adjustable) - 60.5 Hz	Output Power Factor	> 0.95	Max. Output Current	1.44 A (rms)@208V~ / 1.25 A (rms)@240V~	Max. Continuous Output Power	300 W @ 65°C amb.	Max. Output Overcurrent Protection	20 A
5 AC RATING																			
Nominal Output Voltage	208 V~ / 2W - 1Ø 240 V~ / 3W - SPØ																		
Operating Voltage Range	183 - 228V~ / 211 - 264V~																		
Nominal Output Frequency	60 Hz (factory preset)																		
Operating Frequency Range	57 to 59.8 (Adjustable) - 60.5 Hz																		
Output Power Factor	> 0.95																		
Max. Output Current	1.44 A (rms)@208V~ / 1.25 A (rms)@240V~																		
Max. Continuous Output Power	300 W @ 65°C amb.																		
Max. Output Overcurrent Protection	20 A																		
<p>6. Environmental rating</p>	<p>Operating Ambient Temperature: -40 to +75 °C (-40 to +167 °F), with Output Power Derating (1)</p> <p>Type of Enclosure: NEMA 4X</p> <p>DC Ground Fault Detector/Interrupter is Provided</p> <p>(1): For More Details Refer to the Instructions Manual</p> <p>Contains FCC ID: X6W-EMBZ This device complies with part 15 of the FCC Rules. Operation is subject to the following two conditions: (1) This device may not cause harmful interference and (2) this device must accept any interference received, including interference that may cause undesired operation.</p>																		
<p>7. Serial number 8. MAC address</p>	<p>SERIAL NUMBER: 7 3L03021F400 0000013012</p> <p>MAC ADDRESS: 8 AA:BB:CC:DD:EE:FF:GG:HH</p>																		

Product identification label

The sample product shown provides the following information:



MICRO-0.XX-I-OUTD-VVV	• Inverter model
P/N: Pppppppppp	• Inverter Part Number
S/N: SSSSSS	• Inverter Serial Number
WK: WW/YY	• Week/Year of manufacture
MAC: AA:BB:CC:DD:EE:FF:GG:HH	• Inverter MAC address
SJJJJJJJ	
QN	

The identification label on the inverter is shown below. A duplicate identification label, and the product label above, are attached to the inverter in a plastic bag as shown below. Use the small label to create a map of the system for use with the monitoring software. A template to be used for the diagram can be found in part 7. It is recommended to make a copy of the map for the installer.

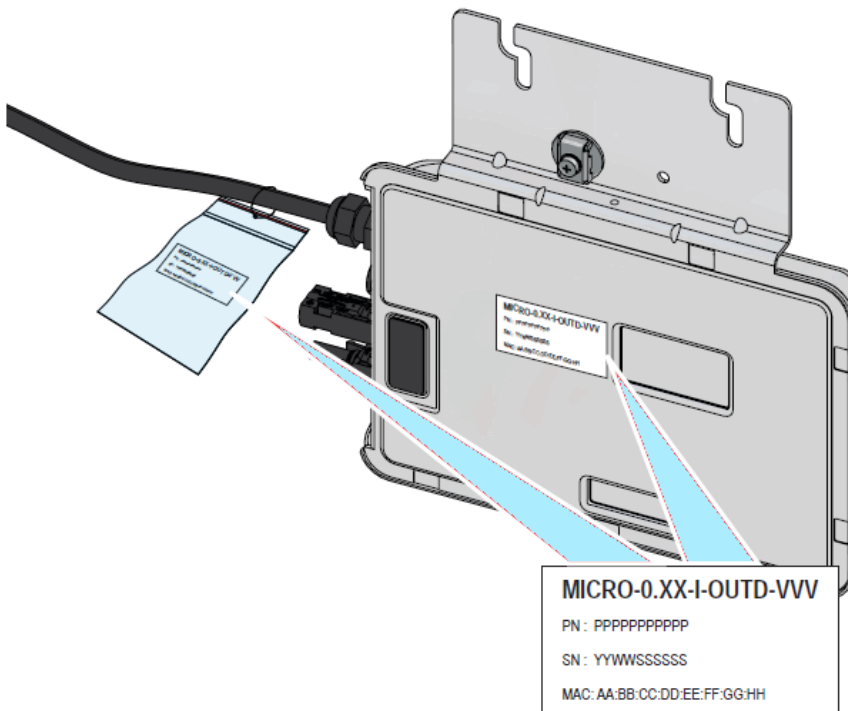

Installation location

2





Transportation and handling

When being transported, the inverter and electronic components must be protected from vibration, mechanical shocks, humidity, etc.

Incoming inspection

It is the customer's responsibility to examine the condition of the unit. Upon receipt of the inverter check the following:

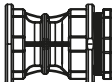
- Inspect the shipping container for any external damage.
- Inventory the contents against list below; verify receipt of all items.
- Use care not to discard any equipment, parts, or manuals.
- Call the delivering carrier if damage or shortage is detected.
- If inspection reveals damage to the inverter, contact the supplier, or authorized distributor for a repair/return determination and instructions regarding the process.

Components supplied with equipment	Description
AC-TRUNK SPOOL-41 inches-50 plugs AC-TRUNK SPOOL-67 inches-32 plugs AC-TRUNK SPOOL-81 inches-27 plugs	AC cable (4 conductors), 10 AWG 3 sizes available as shown at left
	
AC trunk plug cap	Insulated AC cap for AC Bus connectors (female)
	
AC trunk end cap	End cap for 10 AWG AC cable
	
AC trunk unlock tool	Tool for releasing connectors
	

Overall dimensions and minimum clearances

The following figure illustrates the overall dimensions of the inverter.

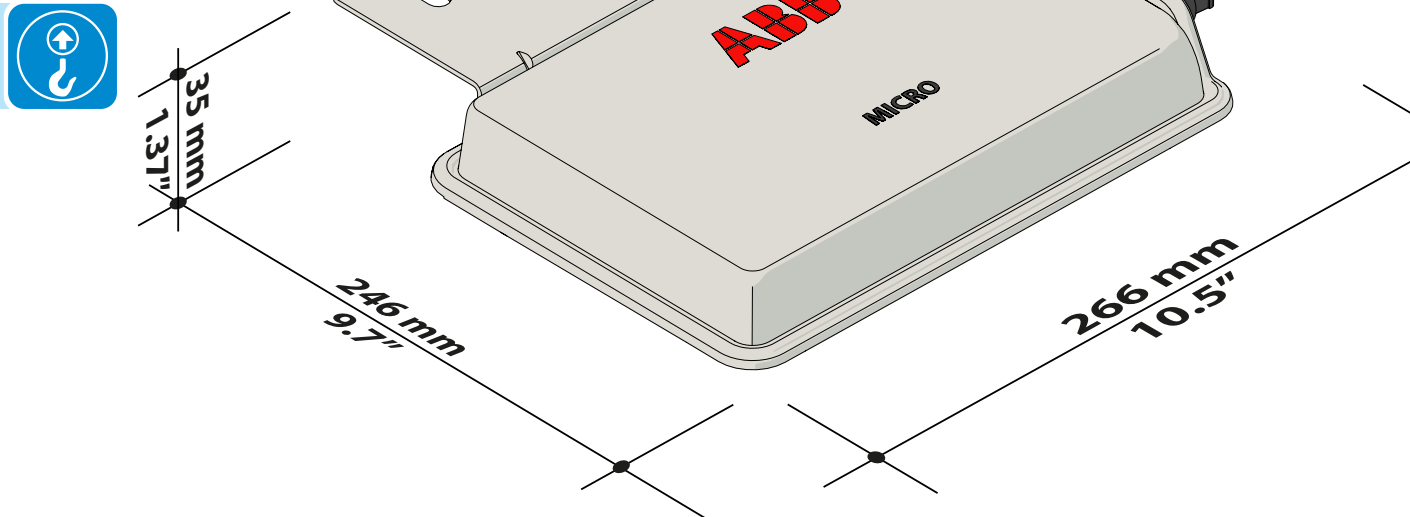

The figure below illustrates the minimum clearances above and below the inverter in relation to the PV modules and roof.

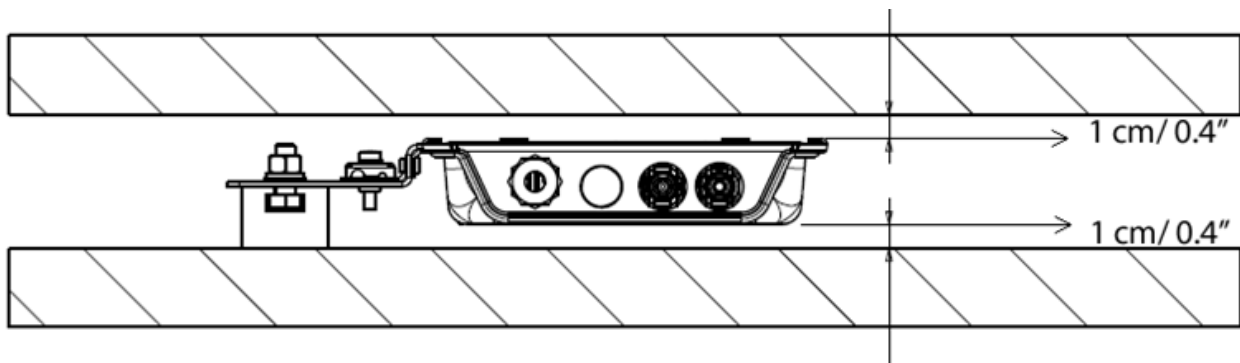

Environmental check of installation location

- See technical data in part 7 to check the environmental parameters to be observed (degree of protection, temperature, humidity, altitude, etc.)
- The maximum operational ambient air temperature **MUST** be considered when choosing the inverter installation location.
- Installing the inverter where operating temperatures exceed the specifications will result in power limiting; it is recommended the inverter be installed within the specified temperature range.
- To avoid overheating, always make sure the flow of air around the inverter is not blocked.
- Do not install in places where gasses or flammable substances may be present.
- Avoid electromagnetic interference that can compromise the correct operation of electronic equipment.

Installation position

When choosing the installation location and position, observe with the following conditions:

- Install only on structures specifically intended for photovoltaic modules (supplied by installation technicians).
- Install the inverter underneath the photovoltaic modules so that they work in the shade; if this condition cannot be met, the inverter could undergo power reduction.
- Any maintenance or replacement of the device could require the technician to dismount the photovoltaic module mounted on the top of the MICRO inverter.
- Ensure that the safety distances are correct for normal test and maintenance operations.
- The distance between MICRO inverters installed on the same system array depends on the type of photovoltaic modules and orientation (horizontal or vertical).

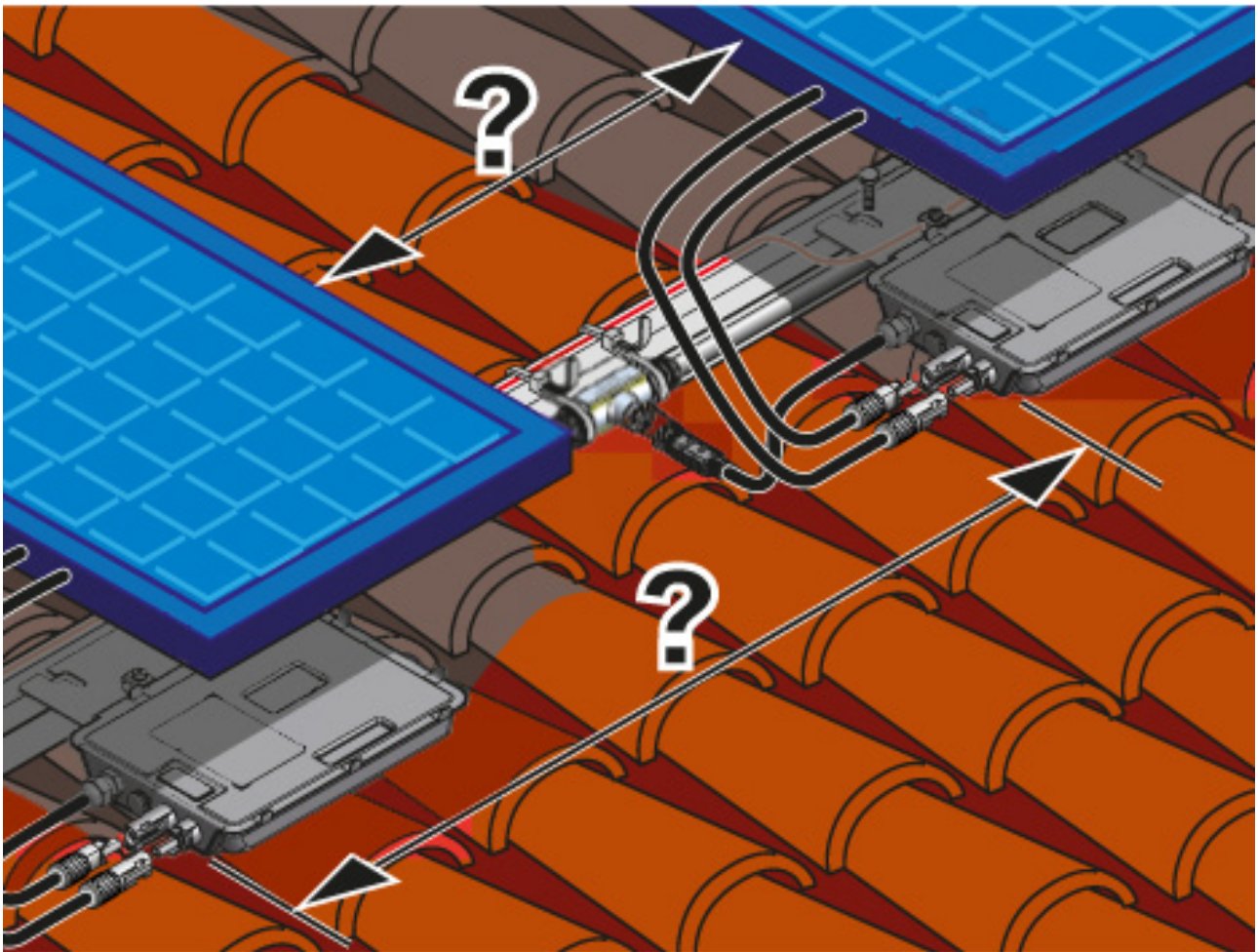

Choice of AC cable

The AC cable is shipped on a reel with the connectors pre-mounted. The available spacing between connectors is: 41", 67", and 81".

The installer is responsible for choosing the AC cable model with the correct spacing on the basis of the orientation (shown below) and type of photovoltaic modules.



See technical data in the appendix concerning the maximum number of MICRO inverters permitted for installation at each cable section!



Figures below show AC cable available for horizontal orientation of the PV modules.

- AC-Trunk Spool – 67 inches, 32 plugs *
- Ideal for 60-cell or 96-cell PV modules

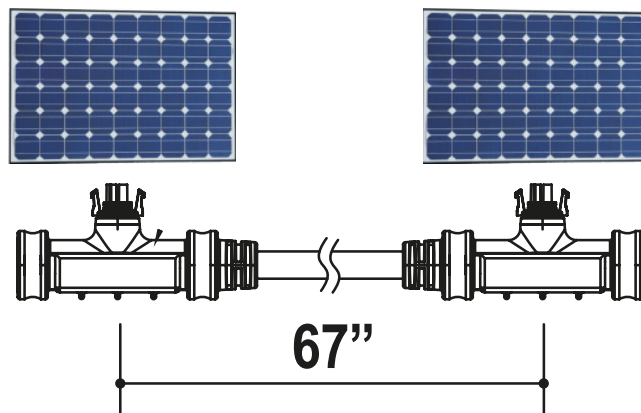

- AC-Trunk Spool – 81 inches, 27 plugs *
- Ideal for 72-cell PV modules
-

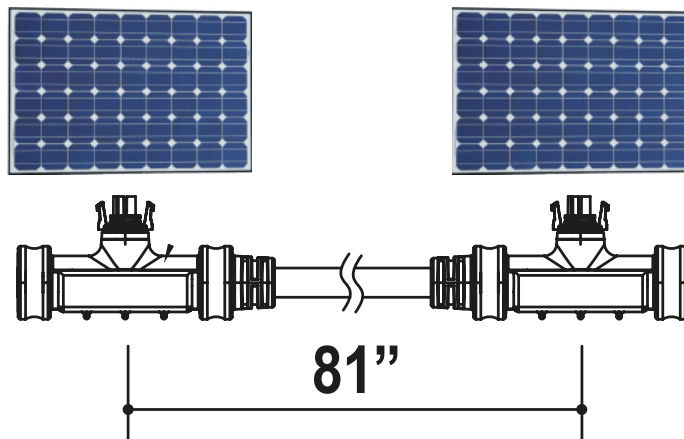

***The AC-TRUNK SPOOL will contain a number of connectors indicated by the number of plugs in the part number. The installer can cut the cable to the length needed for the specific installation.**

The figure below shows the AC cable available for vertical orientation of the PV modules.

- AC-Trunk Spool – 41 inches, 50 plugs *
- Ideal for 60-cell, 72-cell, 96-cell PV modules

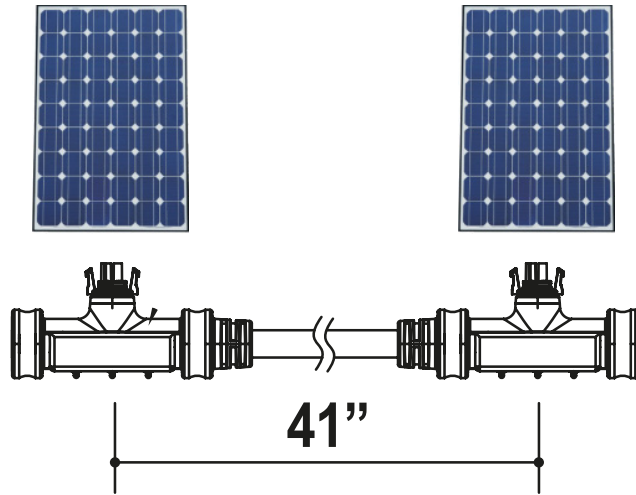



Assembly diagram

- 01 photovoltaic module
- 02 frame
- 03 junction box
- 04 MICRO inverter
- 05 DC cables from PV module
- 06 AC-TRUNK cable plug (connector)
- 07 AC-TRUNK cable temporary plug cap (discard after installation)
- 08 AC-TRUNK PLUG CAP
- 09 MICRO inverter AC drop cable
- 10 AC-TRUNK UNLOCK TOOL
- 11 AC-TRUNK END CAP

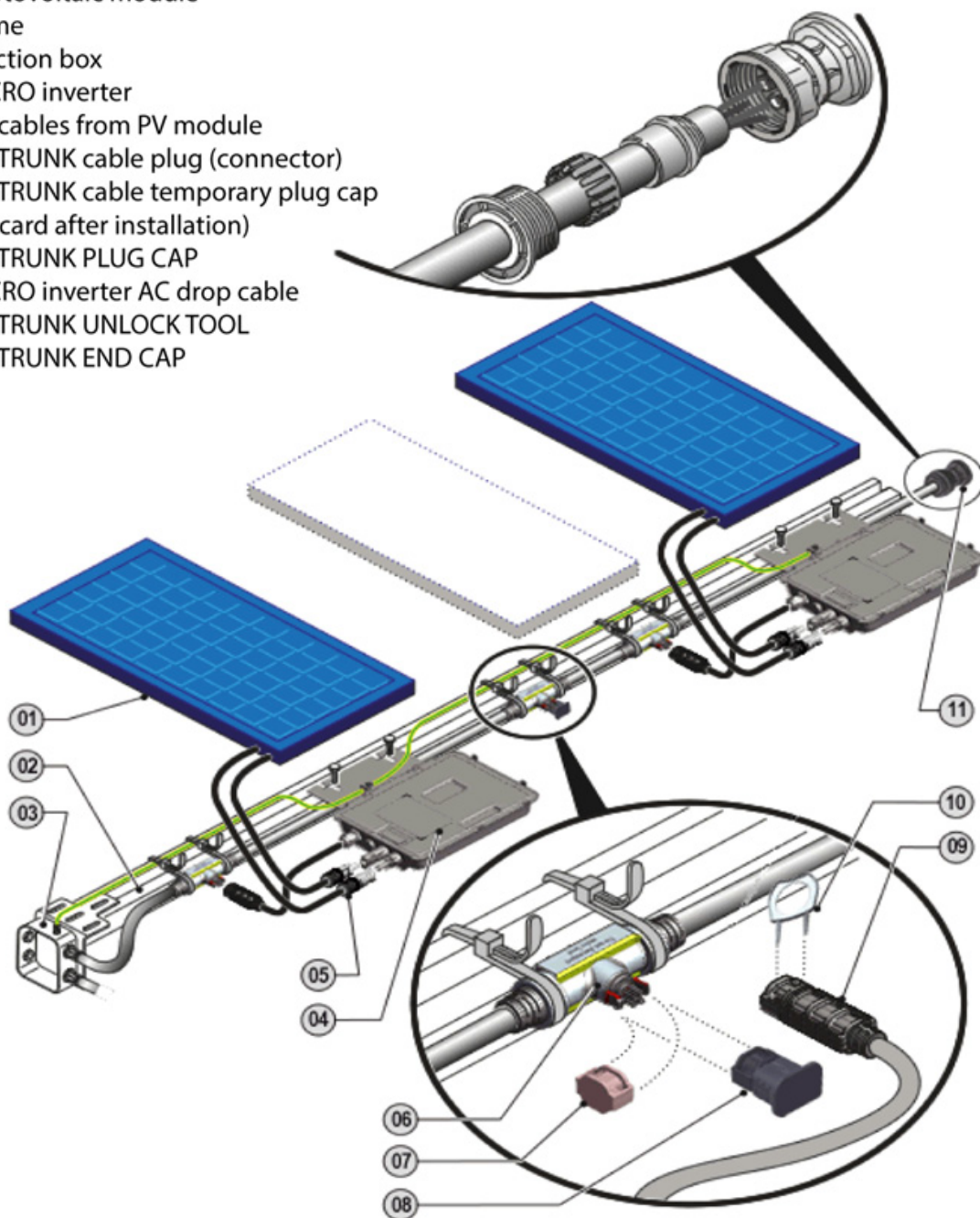

Assembly instructions

1. Run the AC cable along the racking system used for installing the photovoltaic modules.

The cable must be compatible with the expected installation conditions, particularly concerning the number of modules and their orientation (portrait or landscape).



Legislation in force in the country of installation and the installed power will determine the maximum number of MICRO inverters permitted for installation at each AC cable section.

Do NOT exceed the maximum number of MICRO inverters permitted for installation! (See technical data found in the appendix, part 7, of this manual.)



2. Secure the MICRO inverter to the racking system with the logo side facing downwards.
 - Torque the MICRO inverter fasteners to the values shown below, do not over torque.
 - 6 mm (1/4") mounting hardware: 5 N m (45 to 50 in-lbs).
 - 8 mm (5/16") mounting hardware: 9 N m (80 to 85 in-lbs).
 - Mark the approximate center of each photovoltaic module on the frame in order to facilitate positioning.

3. The inverter and photovoltaic modules must be connected to a DC grounding electrode conductor in accordance with the pertinent legislation in force in the country of installation.

The inverter can be earth grounded using the clamp secured to the chassis and an adequately-sized conductor.

There are two possible configurations for grounding the inverters shown on the following pages.

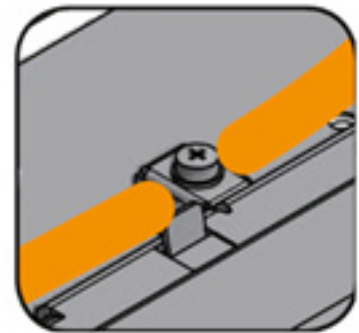

The equipment grounding conductor is incorporated in the AC trunk cable. Incorrect grounding can cause physical injury, death or equipment malfunction and increase electromagnetic interference.

Make sure that grounding conductors are adequately sized as required by safety regulations.

DC grounding electrode conductor coupling all the MICRO inverters

- The conductor must have a minimum cross section of 6 AWG.
- Tighten with 2Nm (17.7 in-lb) torque.

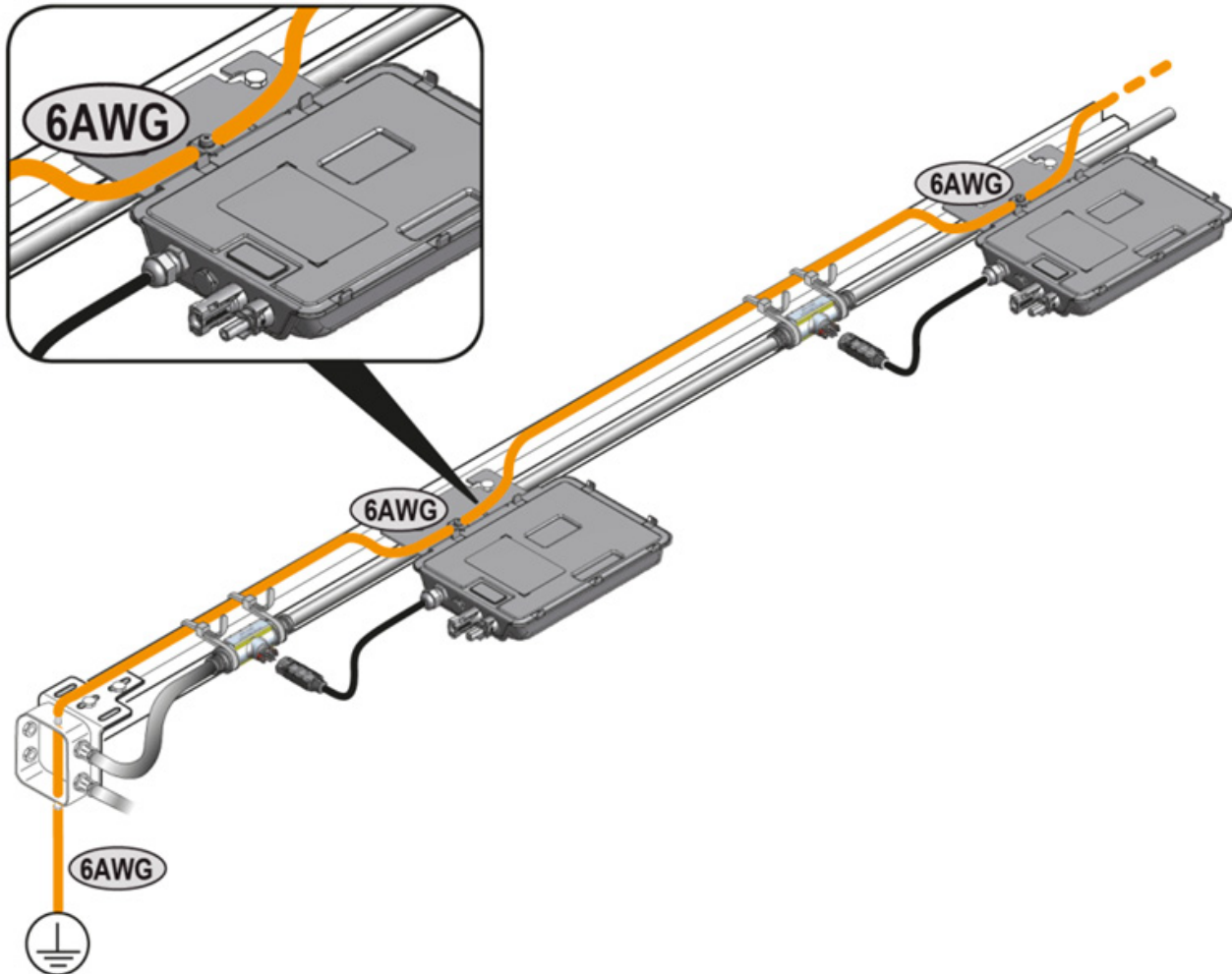

DC grounding electrode conductors for each MICRO inverter

- The conductor linking the assembly to the grounding distribution structure must be at least 6 AWG.
- Tighten with 2Nm (17.7 in-lb) torque.
- Ensure that the quality of the bond made between the conductor and the structure is secure.
- Only a racking system that is certified for use as a grounding structure is permitted to use this method.

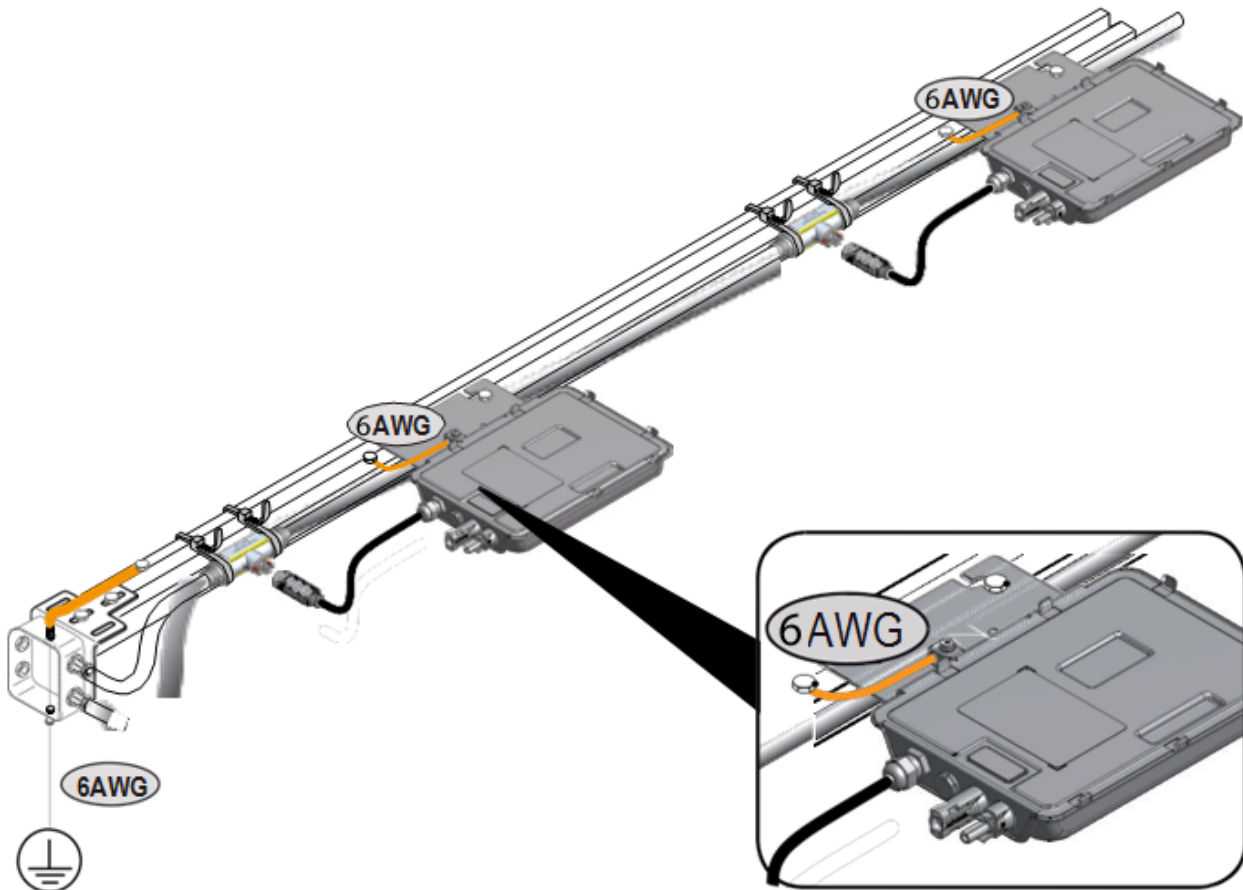

4. Fasten the AC-TRUNK cable to the frame with listed cable ties. Each connector is provided with two guides for ideal fastening. Cable ties are not supplied with the inverter or AC-TRUNK cable. Use listed cable ties rated to 75°C.

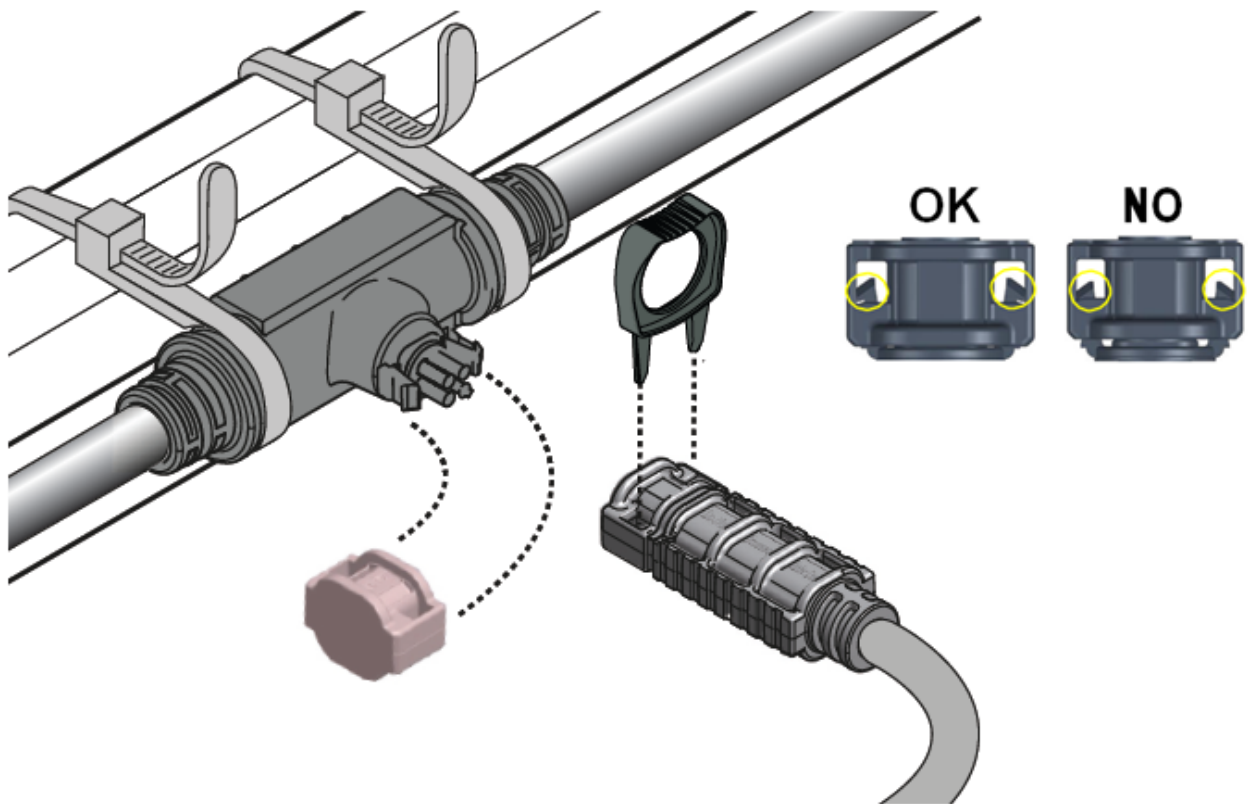

5. Remove the temporary cap from AC-TRUNK cable connectors and then connect the MICRO inverters. The connectors are coupled correctly when two clicks are heard. Be mindful to keep the connectors in a position accessible to the AC-TRUNK cable coming from the MICRO inverter.

Protect any unused AC-TRUNK cable connectors by fitting the AC-TRUNK PLUG CAP on them to keep them watertight. The temporary caps are only attached for shipping and provide no seal!

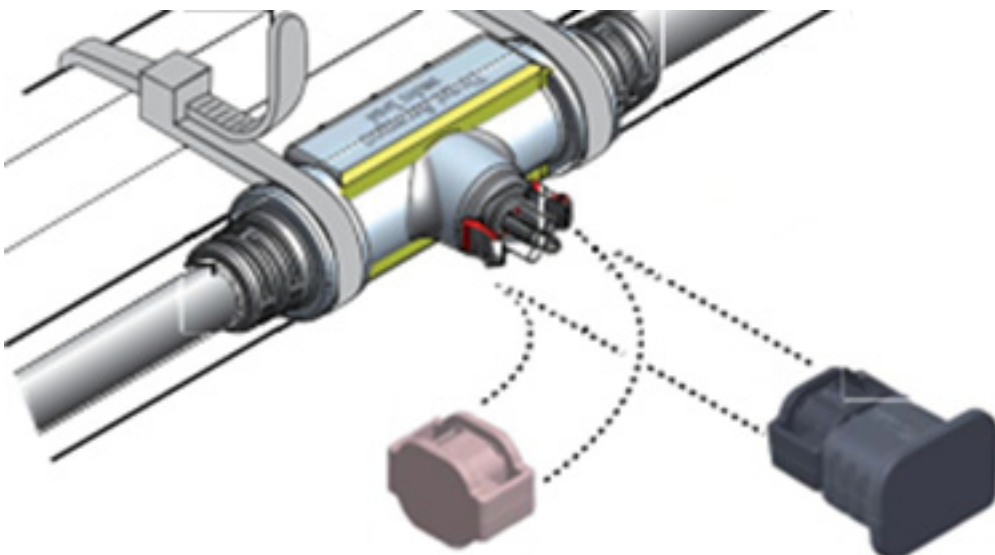

6. Fit the appropriate AC-trunk end cap on the unused ends of the AC-trunk cable.



Connect the AC-TRUNK cable/s coming from the MICRO inverters to the junction box or to the AC distribution panel.

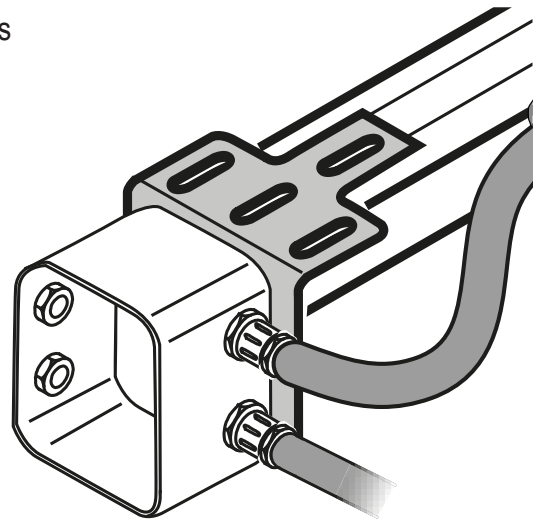

8. Use the duplicate label in the attached plastic bag to create a map of the system by placing the adhesive labels on the diagram (found in the appendix, part 7).

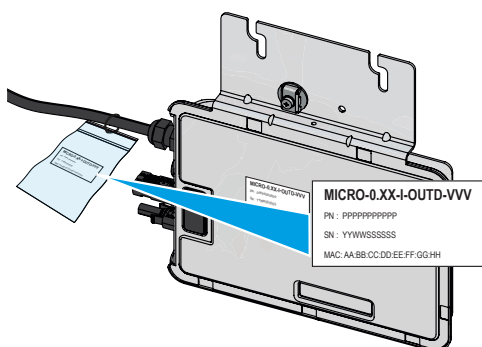

	1	2	3	4	5
A	MICRO-0.XX-I-OUTD-VV FN: PXXXXXXXXX SN: YYWSSSSS MAC: AA-BB-CC-DD-EE-FF-GG-HH				
B					
C					
D					
E					
F					
Azimuth: Tilt:		Orientation : 		Affix the detachable label of each inverter to the applicable field on the map.	

ABB

9. Plug the DC cables into the corresponding inputs on the MICRO inverters and install the photovoltaic modules.

- It is recommended to install the MICRO inverters underneath the PV modules to operate in the shade.
- Direct sunlight may cause elevated temperatures and consequently power limiting.
- Each module must be connected to the MICRO-Inverter with a DC cable having a length of less than 3m.

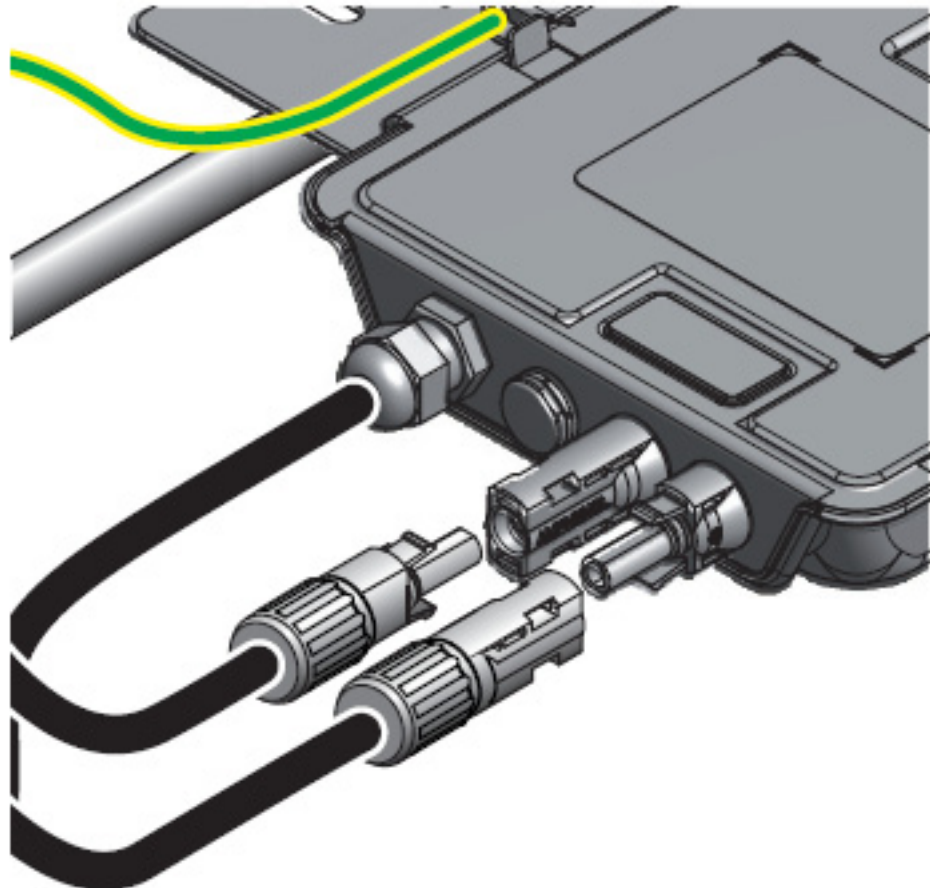

10. The inverter will not begin to feed energy into the distribution grid until the association procedure of the CDD (Concentrator Data Device) has been completed. It is required that an CDD be installed with any MICRO inverter in compliance with UL1741, for the purpose of indication and resetting of ground faults.

See the CDD product manual or Quick Installation Guide for the procedures.

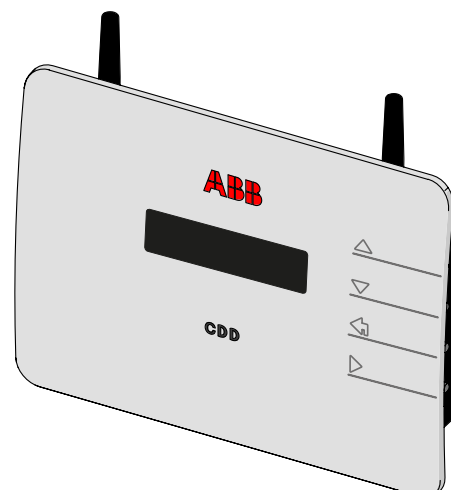

Installing the AC trunk end cap



The unused ends of the AC-trunk cable must be terminated; the following is necessary for properly installing the cap:

- Fit the ring nut and gasket around the cross section of the cable to terminate.
- Strip 18-25 mm/0.7in – 1in of the external insulation and separate each conductor.
- Insert the conductors into the recesses inside the cap to seal them.
- Insert the gasket into the cap with slight pressure.
- Screw the ring nut to apply the correct pressure on the gasket (max.2.45Nm/1.81 ft-lbs).
- Secure the section of the terminated cable to the frame structure with cable ties.

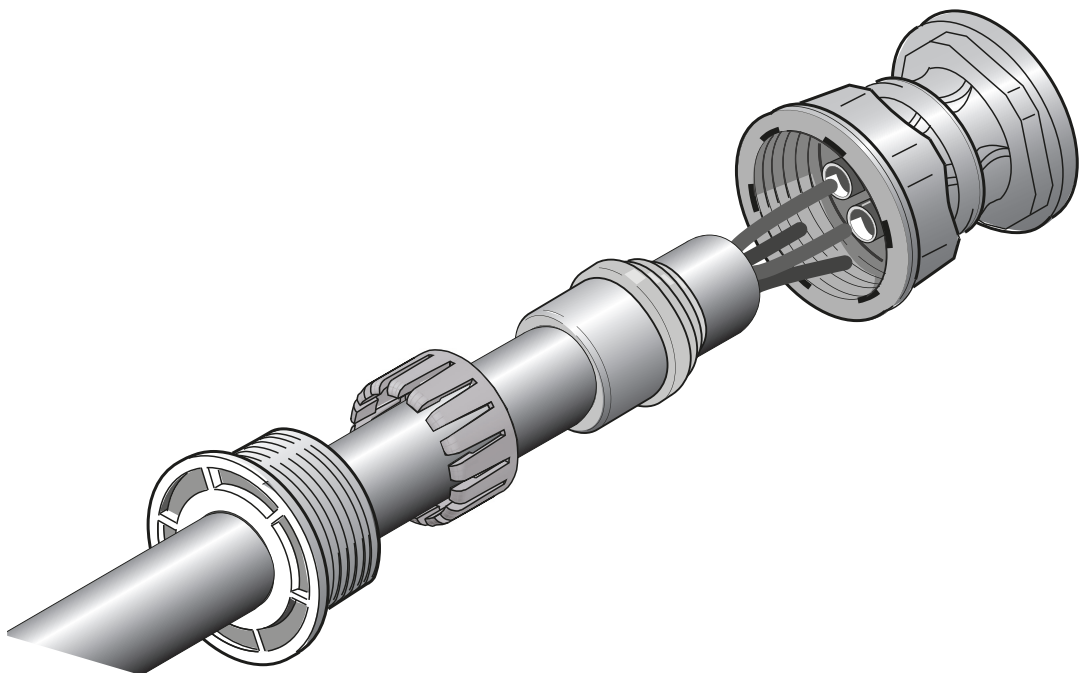

Use of the AC trunk unlock tool

The AC trunk unlock tool must be used to disconnect the AC connector from the MICRO inverter or to remove the AC trunk plug from the connectors on the AC trunk cable.

The tool is used to release the two retaining clips on the connectors of the AC trunk cables. The disconnection or cap removal can be performed in three simple steps:

- Insert the AC trunk unlock tool in the two holes on the connector or cap.
- Press to release the retaining clips.
- Remove the connector or cap



The figures below illustrate the use of the AC-trunk unlock tool.

Disconnection of the MICRO inverter AC cable:

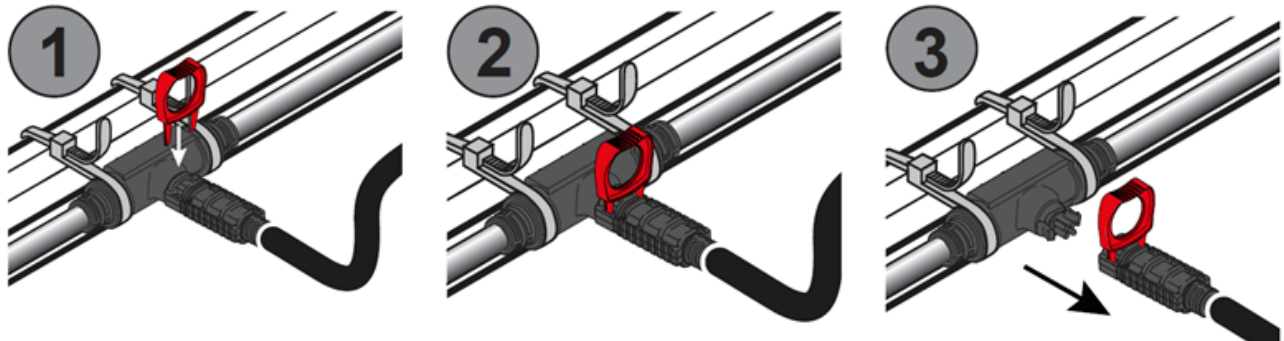

Removal of the AC trunk plug cap

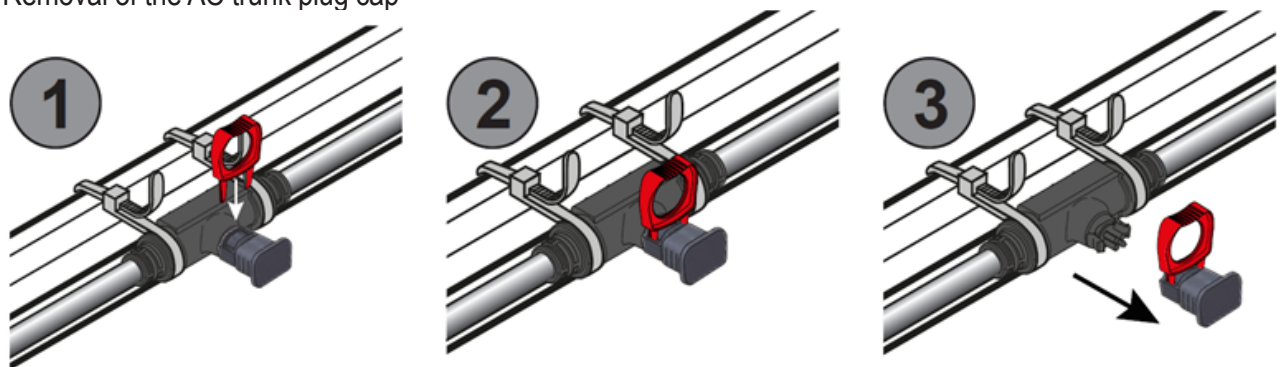

Wiring details

Load protection switch (AC disconnect switch)

The dimensions of the thermal-magnetic circuit breaker should be determined by the number of MICRO inverters connected to a single AC line. A 20A thermal-magnetic circuit breaker represents the maximum value permitted for installation in a single AC line, sized based on the AC cable cross section (10 AWG).

It is the installer's responsibility to adequately size the overcurrent protection, based on the number and types of MICRO inverters in the system, see table 3-1 below.

Protection breaker rating table 3-1		6A	10A	16A	20A
Max number of inverters @240VAC	MICRO-0.25	4	7	12	15
	MICRO-0.3 MICRO-0.3HV	3	6	9	12
Max number of inverters @208VAC	MICRO-0.25	4	6	10	13
	MICRO-0.3 MICRO-0.3HV	3	5	8	11

Differential protection downstream of the inverter

ABB Micro inverters with a high frequency transformer are equipped with an isolation transformer for each of the DC/DC converters which operate at high frequency (switch-over frequency of the converter). This transformer allows for high frequency galvanic isolation between the DC and AC side of the system. In addition to this the inverters include protection mechanisms so that they cannot input ground fault currents.

The use of a switch with type A or AC differential magnetothermal protection with $I\Delta n=30\text{mA}$ sensitivity is recommended.

Choosing the interface protection system and device downstream of the inverter

The inverter does not include any electromechanical devices (relays, contactors, etc.) for automatic disconnection from the power grid. The system must be provided with external protection for the physical disconnection of the MICRO inverters from the grid, in compliance with the applicable regulations and with the requirements of the installation country's power distributor.

Such protection is typically composed of an interface protection system that analyzes and controls the grid parameters and, if necessary, sends commands to the interface device, in charge of physically disconnecting the PV installation MICRO inverters line.

CAUTION: To reduce the risk of fire, connect only to a circuit provided with 20A maximum branch circuit overcurrent protection in accordance with the National Electric Code (ANSI/NFPA 70)

AC grid connections



To prevent electrical hazards, all the connection operations must be carried out with the disconnect switch downstream of the inverter (grid side) open and locked.

- When connecting to the grid, all the AC cables coming from MICRO inverters must be joined inside a junction box.
- A single line cable must then form the connection to the distribution grid.
- Be mindful of the dimensions of the line cable. The grounding connection from the inverters is obligatory.
- A 4-wire AC cable must be used and maximum trunk cable allowed beyond the last inverter is limited to 15 feet.
- All the external connections to the insulated junction box (caps, adapters, etc.) must be made with securely-sealed ABB components.

Characteristics and sizing of the line cable

- The line cable (not supplied by ABB) runs between the junction box and the load distribution panel.
- The cross-section of the AC line conductor must be sized in order to prevent unwanted disconnections of the inverter from the grid due to high impedance of the line that connects the inverter to the power supply point.
- If the impedance is too high, it causes an increase in the AC voltage that, on reaching the limit set by the country of installation, causes the inverter to switch OFF.



The installation technician is responsible for selecting a cable of the appropriate length and cross section; refer to the technical data in the appendix.

Wiring of AC cable

The AC cables from the MICRO inverters have four conductors with different colors to identify the function of each conductor:

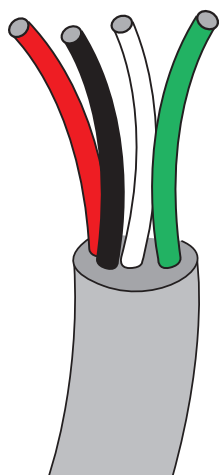

L1
red

L2
black

Neutral
white

Ground
Green

<p>AC-trunk spool -41 inches-50 plugs</p> <p style="text-align: center;">41"</p>	<p>AC cable (4 conductors): 10 AWG, wheelbase 41" 40 connectors</p>
<p>AC-trunk spool -67 inches-32 plugs</p> <p style="text-align: center;">67"</p>	<p>AC cable (4 conductors): 10 AWG wheelbase 67" 32 connectors</p>
<p>AC-trunk spool -81 inches-27 plugs</p> <p style="text-align: center;">81"</p>	<p>AC cable (4 conductors): 10 AWG wheelbase 81" 27 connectors</p>



The installation technician is responsible for selecting a junction box with the appropriate dimensions and insulation. Do not to reverse the phase with the neutral!

Close the junction box after the wiring is complete. Confirm that the seal is tight.

When connecting the inverter to the distribution grid, the configuration is made with the CDD. It is required that the CDD be installed with any ABB MICRO inverter in compliance with UL1741, for the purpose of indication and resetting of ground faults.



Commissioning



The MICRO inverter operating state is controlled through the CDD. The MICRO inverters must be acquired using the CDD before commissioning the inverter.

For commissioning and operation of the equipment, it is necessary to have a thorough knowledge of the CDD equipment and the functions that have been enabled in the installation. The CDD Quick Installation Guide is shipped with the CDD and can be found on the website along with the CDD product manual.

- When conducting the checks, confirm that the main AC disconnect (downstream from the system) and any other possible isolator switches are open.
- Confirm that all conductors and protective grounding points are connected.
- Check the position of all connection cables and the tightness of all nuts and terminals.
- Ensure that all electrical safeguards have been correctly installed.

Sequence of operations

- The steps to take for configuring the CDD, acquiring the MICRO inverters in the system and registering at the “AURORA VISION” portal are described in the both the CDD Quick Installation Guide or CDD product manual.
- Close the AC breaker (downstream from the system) and any other isolation switches to connect the system to the AC grid.
- Verify that all inverters are operational and harvesting energy by reviewing the CDD monitoring page. This step can be performed only when the PV modules have sufficient sunlight to harvest energy.



The incoming voltage must not exceed the maximum values shown in the technical data in order to avoid damaging the equipment. Consult the technical data in the appendix, part 7 of this manual for further details.

The following table describes the behavior of the LED during the startup phase and the static phase of the commissioning. For MICRO inverters without an LED on the front panel, the ground fault and other indications are reported on the CDD display and monitoring webpage.

LED indicators

LED behavior of MICRO inverters with LED on front panel

Phase	System Status	Description	DC Power	Grid Connection	Duration	GREEN	RED
-------	---------------	-------------	----------	-----------------	----------	-------	-----

START UP PHASE (first 10 seconds during start up, followed by STATIC PHASE)

1	Start up	MICRO virgin	ON	OFF	10sec.	50% DUTY CYCLE, PERIOD 2SEC	OFF
2	Start up	MICRO acquired	ON	OFF	10sec.	SOLID GREEN	OFF

STATIC PHASE

3	Off	No DC present	OFF	OFF	Continuous	OFF	OFF
4	Alarm	Boot issue	ON	OFF	Continuous	OFF	50% DUTY CYCLE, PERIOD 1SEC (refer to CDD)
5	Alarm	Ground Fault	ON	OFF	Continuous	OFF	SOLID RED
6	Alarm	Country Standard (CS) issue	ON	OFF	Continuous	OFF	50% DUTY CYCLE, PERIOD 2SEC
7	Alarm	Generic Alarm	ON	OFF	Continuous	50% DUTY CYCLE, PERIOD 2SEC	50% DUTY CYCLE, PERIOD 2SEC
8	Normal	DC present, no alarm, no Grid Conn.	ON	OFF	Continuous	50% DUTY CYCLE, PERIOD 2SEC	OFF
9	Normal	DC present, Grid Connected	ON	ON	Continuous	10% DUTY CYCLE, PERIOD 10SEC	OFF

Phase description

1	MICRO not yet acquired by first connection of CDD
2	MICRO acquired by CDD
3	No DC source
4	MICRO does not load firmware
5	Ground fault detection
6	Loading country standard not compatible with existing firmware
7	MICRO malfunction or grid issue during running (e.g. voltage or frequency exceeding the limits to disconnection)
8	Grid issue at start up (e.g. voltage or frequency exceeding the limits to connection)
9	Normal running, exporting power

Alarm messages generated by the MICRO inverter

The equipment communicates errors/warnings via radio to the associated CDD. Any messages received and related codes can be checked on the display for the CDD. To understand and address warning (Wxxx) or error (Exxx) messages generated by the MICRO inverters and displayed on the CDD, refer to the table below.

Display code LED status Alarm message	Cause	Solution
E001 blinking red Input OC	The error appears when the inverter input current exceeds the set overcurrent threshold. This may be caused by: a) sudden sunlight changes that may generate input current surges into the MICRO inverter b) PV module incompatible with the MICRO inverter input characteristics c) Faulty MICRO inverter	a) The error occurs sporadically and no action is required as the MICRO inverter will automatically reset to normal operation b) It is necessary to verify that the photovoltaic module specifications are compatible with the inverter. c) If conditions a) and b) have been verified and the error persists, the malfunction may be caused by an internal inverter fault.
E004 blinking red Vbulk OV	The error is generated when the voltage at the ends of the bulk capacitors exceeds the Over Voltage threshold. This may be caused by: a) Grid voltage too high b) Internal inverter fault	a) Check that the grid voltage is compatible with the MICRO inverter specifications. In the event of highly abnormal grid voltage, please contact your grid operator to address the problem. b) If no problems are found when checking the grid voltage, the alarm may be caused by internal inverter faults.

Display code LED status Alarm message	Cause	Solution
E006 blinking red Output OC	The error appears when the inverter output current exceeds the internal inverter alarm threshold. This may be caused by: a) High impedance grid with significant voltage variations, even with small loads. b) Internal inverter fault	a) Check that the grid voltage is stable, mainly upon: - loading with high current peak loads. - maximum power generation of the PV system If the grid voltage is unstable, verify the appropriate sizing of the line cable/s, and, if correct, please contact your grid operator to address the problem. b) If no problems are found when checking the grid voltage, the alarm may be caused by internal inverter faults.
E014 blinking green OverTemp	High internal temperature recorded by the inverter. This parameter depends in part on the power that the inverter must supply, as the internal inverter temperature is affected by the heat dissipated internally by its components. This may be caused by: a) Failure to observe the installation conditions b) Internal inverter fault	a) Verify the installation conditions (exposure to sunlight) and check that air flow to the MICRO inverter is not obstructed, so as to permit cooling of the device. Check that the ambient temperature measured around the MICRO inverter does not exceed the limits set in the technical data. b) Verify the MICRO inverter temperature readings (see the Internal Web Server section in the CDD manual). If one of the temperatures remains at a value which is not compatible with the environmental conditions (e.g. -40°C internal temp. reading with 20°C effective ambient temperature), the alarm may be due to internal inverter causes.



Display code LED status Alarm message	Cause	Solution
E018 blinking green Ground fault	The error is generated when a ground leakage current is detected in the DC section of the system. This may be caused by: a) PV module ground leakage b) Internal inverter fault	See the “Verification of ground leakage” and “Measuring the insulation resistance” sections for information on how to perform checks and measurements. a) If the measured insulation resistance value is less than 1K Ω , the PV module has a ground leakage that prevents the grid connection of the inverter. In this case the PV module must be replaced. b) If the measured value exceeds 1K Ω , try connecting the MICRO inverter to a different PV module. If the error persists, the alarm may be caused by internal inverter faults. To perform this test, the MICRO inverter Ground Fault condition must be reset via the Web Server.
E023 Blinking green DC Injection	The error is generated if the DC component of the current supplied to the grid exceeds the threshold set by the country of installation’s applicable regulation. In any case, the inverter will automatically try to reconnect to the grid. This may be caused by: a) Sporadic recurrence of this error is a sign of large grid distortions or sudden changes in irradiance. b) Systematic recurrence of this error may be due to an inverter fault.	a) Verify the grid parameters and, if the grid voltage is strongly distorted, please contact your grid operator to address the problem If the grid voltage is stable, the error may also be due to sudden irradiance variations. In this case, the inverter will automatically try to reconnect to the grid and no actions are required to solve the problem. b) If the grid voltage is stable, yet the error systematically persists, the malfunction may be caused by an internal inverter fault
E024 Blinking red Internal Error	a) The alarm may occur during inverter initialization and is caused by the initialization of communication between the CDD and the MICRO inverters. b) Systematic occurrence of this error may be due to an inverter fault.	a) The alarm will automatically reset upon connection of the inverter to the grid, and no actions are required to solve the problem. b) If the error systematically persists, the malfunction may be caused by an internal inverter fault



Display code LED status Alarm message	Cause	Solution
E051 Solid red Country Not Comp	The set grid standard is not compatible with the firmware installed on the MICRO inverter. This condition may be generated if a MICRO inverter is replaced.	The firmware in the MICRO inverter/s in the installation must be updated to a compatible version. Firmware updates are performed via the Internal Web Server (see the CDD manual), with the software package obtained from customer service.
E052 Solid red Country mismatch	The alarm is generated when the grid standard (selected on the CDD during installation) has not been correctly set on the MICRO inverters. This may be caused by: a) communication problems while setting the grid standard for the MICRO inverter from the CDD: b) poor irradiance while setting the grid standard for the MICRO inverter from the CDD: MICRO inverters are directly supplied by the voltage generated at the panel, and poor irradiance may cause inverter shut downs	a) Verify on the Internal Web Server (as described in the CDD manual), the radio communication quality on each MICRO inverter (values above 60% indicate good reception). If the quality of the received signal is good re-configure the installation, otherwise consider installing the CDD device in a different position to ensure better radio signal quality. b) System configuration must be carried out in good irradiance conditions, in order to guarantee the correct operation of the MICRO inverter and to prevent the risk of shut-downs due to insufficient input voltage generated by the PV module.
E501 Blinking green Communication fault	The alarm is generated when the CDD device does not receive messages from the MICRO-inverter for more than 15 minutes. This may be caused by non-optimal positioning of the CDD.	Consider a new installation position that ensures better communication between the CDD device and the MICRO-inverters. Use the CDD Internal Web Server to verify the signal quality (refer to the CDD manual for information on the Internal Web Server)
W001 Blinking green Vpanel Problem	This alarm is displayed when the input voltage generated at the PV generator is outside the allowed range given in the technical data. This may be caused by: a) Poor sunlight b) Possible shadows that may darken the module during part of the day. b) PV module incompatible with the MICRO inverter input parameters d) Internal inverter fault	a) Wait for appropriate sunlight to guarantee correct operation of the inverter b) Verify that no shadows are present on the PV module when the error is generated c) Verify that the PV module voltage characteristics are compatible with the inverter input specifications. d) If the above checks have yielded positive results, yet the error persists, the malfunction may be caused by the MICRO inverter.



Display code LED status Alarm message	Cause	Solution
W003 Blinking green Grid Fail W004 Blinking green VAC OV W005 Blinking green VAC UV	This alarm is generated when one or more grid parameters lie outside the permitted range set by the country of installation's grid standard. The error code will be followed by a suffix in brackets indicating the grid parameter out of range: (UV) Grid voltage below the set lower limit (OV) Grid voltage above the set upper limit (UF) Grid frequency below the set lower limit (OF) Grid frequency above the set upper limit	If the error is generated only on one of the installation MICRO inverters, this may be due to an inverter fault. If the alarm is generated at multiple inverters in the installation, check the grid voltage for instabilities in any of the 4 parameters monitored by the inverter. If anomalous values are detected, verify the sizing of the AC line conductors. In case of correct sizing, please contact your grid operator to address the problem.
W011 Solid red Vbulk UV	Internal fault of the booster circuit inverter	Contact customer service.
W032 Blinking green Pgrid limitation	MICRO is limiting AC power due to an external condition; not an error but a certain working condition	If problem persists check grid connection condition.
W033 Blinking green Pgrid Fgrid limitation	MICRO is limiting AC power due standard frequency regulation.	If problem persists check grid frequency condition.
W034 Blinking green Pgrid VAC high limitation	MICRO is limiting AC power due to a standard voltage regulation.	If problem persists check grid voltage condition.
W035 Blinking green	Fgrid problem	(UF) grid frequency below the set lower limit (OF) grid frequency above the upper limit



Verification of ground leakage

In the presence of anomalies or report of ground fault, there may be a ground leakage from the photovoltaic module.

To check this, measure the voltage between the positive pole and ground and between the negative pole and ground using a voltmeter.

Behavior of a system without leakage

Due to the capacitive effect of the photovoltaic module, during the first moments that the voltmeter is connected between one of the two poles and ground, it will measure a voltage of about $V_{oc}/2$, which will tend to stabilize to around 0V if there is no ground leakage, as shown in the graph below:

The internal resistance of the voltmeter tends to zero the voltage present on the PV generator due to the capacitive effect

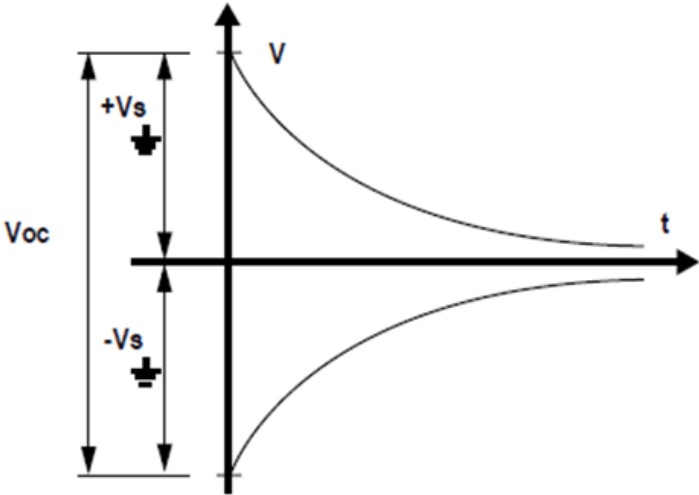

How to make the measurement:

Positive pole Vs Ground

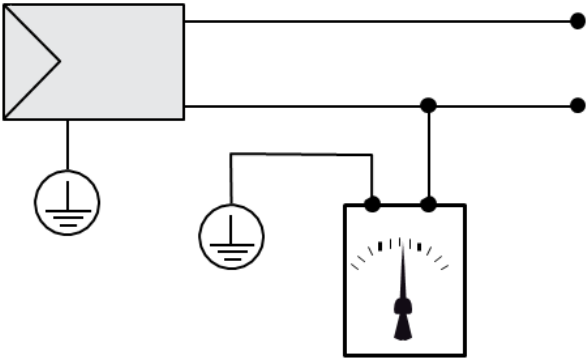

Negative pole Vs Ground

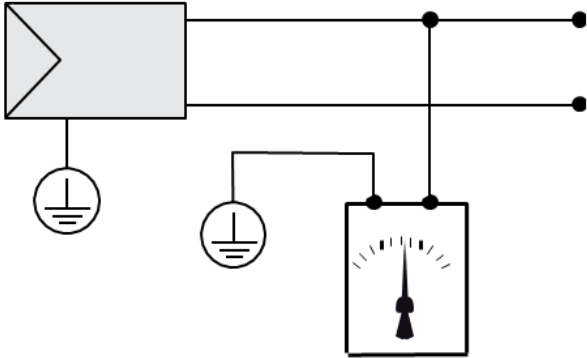

Behavior of a system with leakage

If the voltage measured between one of the two poles and ground does not tend to 0V and stabilizes on a value, there is a ground leakage from the photovoltaic module.

Example: When the measurement is made between positive pole and ground, on a photovoltaic module with $V_{oc}=37V$, a voltage of 7V is measured.

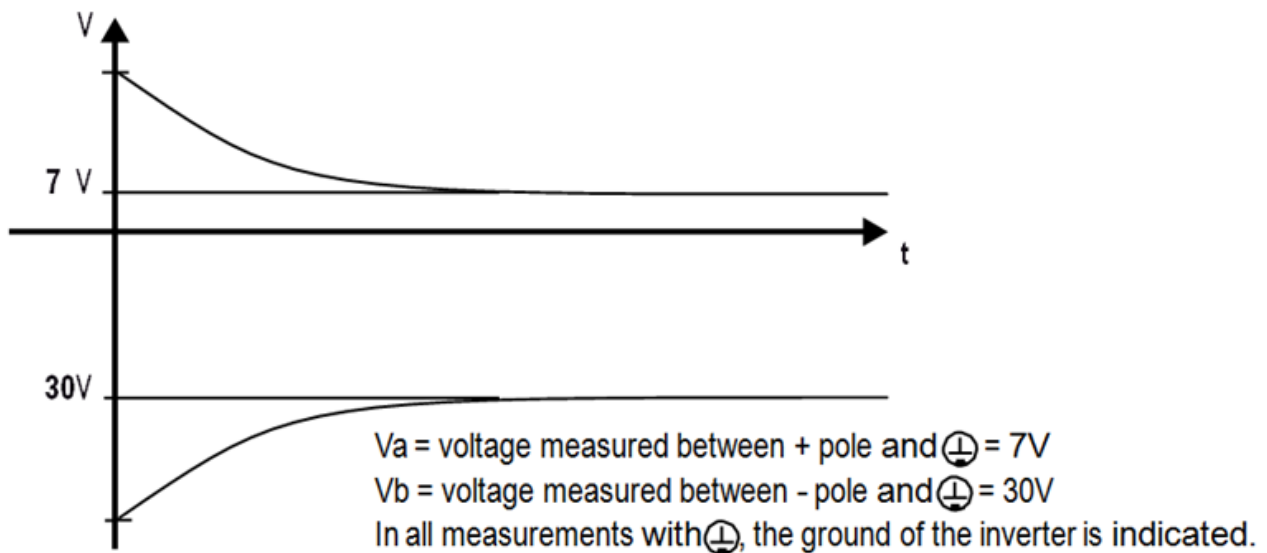

Measuring the insulation resistance of the PV module

To measure the insulation resistance of the photovoltaic module compared to ground, the two poles of the PV generator must be short-circuited (using a suitably sized selector), and verify that the chassis of the module itself is referred to ground (of the inverter).

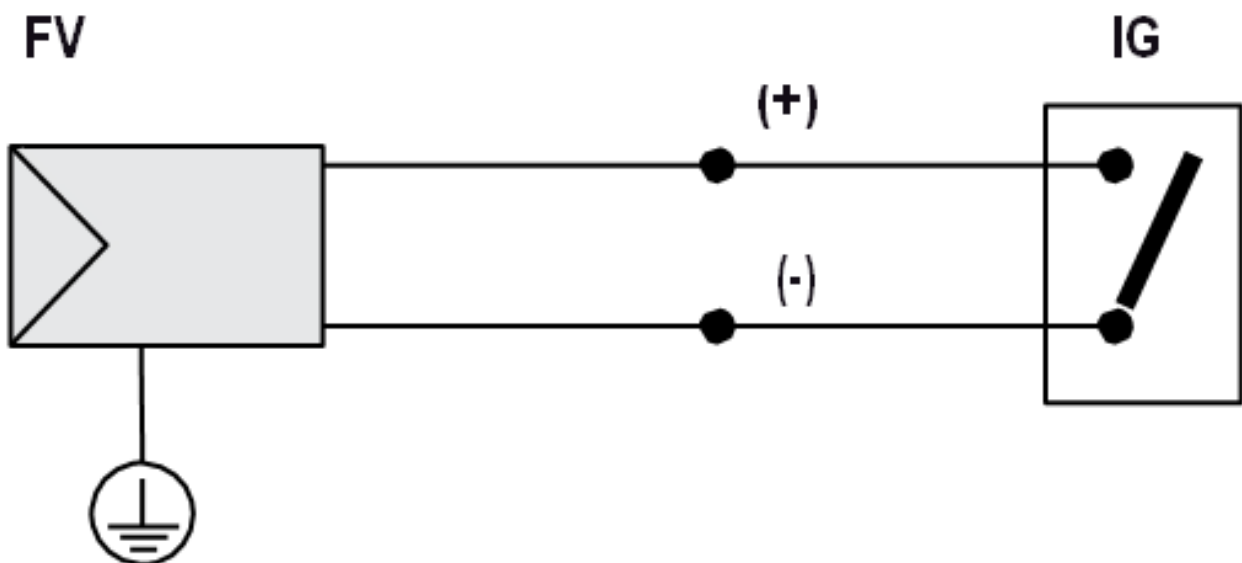

Once the short-circuit has been made, measure the insulation resistance (R_{iso}) using a megohmmeter positioned between the two shorted poles and ground (of the inverter).

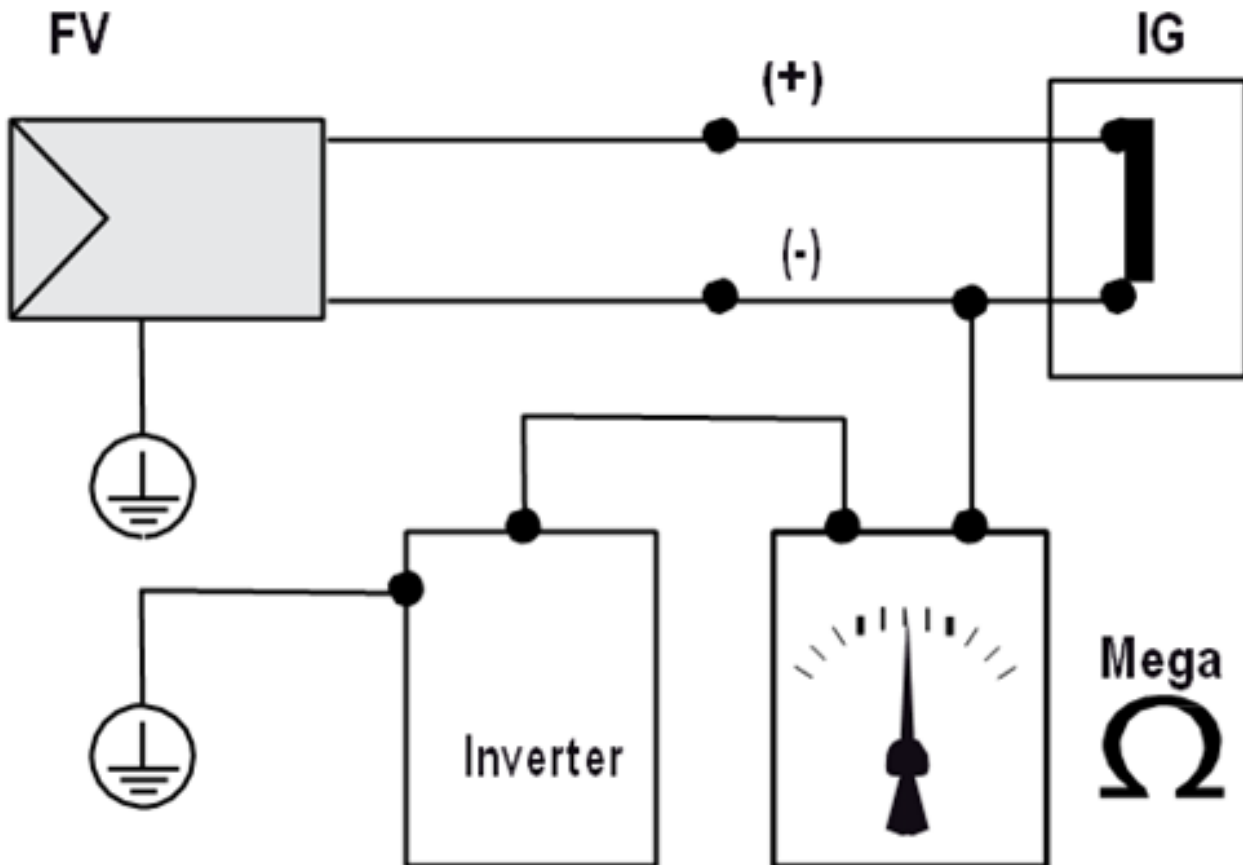

If the measured insulation resistance is less than 1Kohm the inverter does not connect to the grid due to a low insulation of photovoltaic module respect to ground.

The insulation resistance is affected by the environmental conditions the photovoltaic module is in (E.g.: photovoltaic module wet from dump or rain); therefore, the measurement must be made immediately after the anomaly.

Making a service call

Call technical support at 877-261-1374. The following information is necessary to initiate a call. The model number, serial number, and week of production can be found on the INFORMATION menu of the CDD display and on the product label:

Model number

Serial number

Week of production

State of LED:

- Status of light(s)
- Steady or flashing
- Error message or code

Identify the System structure:

- Information on the PV field
- Brand and model of PV panels

Provide a description of the conditions:

- Can the fault be reproduced? If so, how?
- Is the fault cyclical in nature? If so, how often?
- Was the fault apparent at the time of installation? If so, has it worsened?
- Describe the atmospheric conditions at the time the fault appears/appeared.

Routine maintenance

Routine maintenance is recommended to maintain efficient operation of the PV installation. For cleaning, DO NOT use rags made of filamentary material or corrosive products that may corrode parts of the equipment or generate electrostatic charges. The maintenance schedule may vary depending on the environmental conditions of the installation site.



Maintenance operations must be carried out with the equipment disconnected from the grid (power switch open) and the photovoltaic modules obscured or isolated, unless otherwise indicated.

The table below describes routine maintenance recommended to maintain efficient operation of the installation.

Annual operations	Check that there has been no drastic change in the installation conditions that might have a negative influence on radio communication with the MICRO inverter.
Annual cleaning	Conduct an annual visual inspection (where possible) on the various components (DC cables, MICRO inverters, and AC cables) to check for dust, dirt, moisture and water seepage.



***Do not attempt to dismantle the equipment or make any internal repairs!
In order to preserve the integrity of their safety and insulation, MICRO inverters are not designed to allow internal repairs.***

The AC output wiring harness (AC drop cable on the MICRO inverter) cannot be replaced. If the cord is damaged the equipment should be scrapped.

Storage and dismantling

If the equipment is not used immediately or is stored for long periods, check that it is packaged correctly and contact customer service for storage instructions. The equipment must be stored in well-ventilated indoor areas in a noncorrosive environment. Restarting after a long period requires the removal of oxidation and dust that may have settled inside the equipment if not suitably protected.

ABB CANNOT be held responsible for disposal of the equipment, displays, cables, batteries, etc. The customer must dispose of these substances, which are potentially harmful to the environment, in accordance with the regulations in force in the country of installation.

If the equipment is dismantled, follow the regulations in force in the country of destination and avoid causing any kind of pollution upon disposal. Use dumps suitable for disposal of the various types of materials listed below.

<u>COMPONENT</u>	<u>MATERIAL OF CONSTRUCTION</u>
Frame, brackets, supports	Arc-welded steel FE37
Casing or covers	ABS, plastic
Paint and	RAL
Gaskets and seals	Rubber / Teflon / Viton
Electrical cables	Copper / Rubber
Conduits	Polyethylene / Nylon
Back-up battery	Nickel / Lead/ Lithium



The MICRO inverter system

This system is composed of a group of MICRO Inverters that convert direct electric current from a photovoltaic module into alternating electric current and feed it into the utility grid.

Photovoltaic modules transform energy from the sun into direct current (DC) electrical energy (through a photovoltaic field, also called photovoltaic module). In order to use it, it is necessary to transform the type of current into alternating “AC”. This conversion, known as DC to AC inversion, is made efficiently without using rotating parts and only through static electronic devices.

In order to allow inverter operation in safe thermal and electrical conditions, in the event of adverse environmental conditions or unsuitable input voltage values, the unit automatically reduces the value of the power fed into the grid. This way the solar energy system compensates for the energy drawn from the utilities connected to the grid to which it is linked. The solar energy system then powers all connected electrical devices, from lighting to household appliances, etc.

When the photovoltaic system is not supplying sufficient power, the power needed to ensure normal operation of the connected electrical devices is drawn from the utility grid. If, on the other hand, excess power is produced, this is fed directly into the grid, becoming available to other consumers.

In accordance with local and national regulations, the power produced can be sold to the grid or credited towards future consumption. Each inverter will work independently of the others and will supply the grid with the maximum power available from its photovoltaic panel.

Characteristics of MICRO inverters

Unlike systems subdivided into strings controlled by one or several inverters, systems of this sort are built for the incorporation of a MICRO inverter for each photovoltaic module.

Each MICRO inverter works independently of the others, and its own photovoltaic module supplies the maximum power available to the grid. This setup enables a direct control over the production of a single photovoltaic module, consequently optimizing production as much as possible.

Functionality of the equipment

Data transmission and control

The MICRO inverters are monitored remotely through an advanced communications system based on a wireless connection and the CDD. In addition to local monitoring of the system, it is possible to have remote data visualization through an internet access to AURORA® VISION web portal.

Single photovoltaic module management benefit

There are many advantages of having each MICRO inverter monitor a single photovoltaic module:

- Capability of viewing each module's production
- Possibility of controlling when to clean each module, as necessary
- Ease of service interventions from the possibility of singling out individual modules or inverter that are down.
- Preservation of production even if there is a malfunctioning module or inverter

Protective devices

Anti-Islanding

In accordance with required national standards and laws, in the event of a local grid outage by the utility, or when the grid equipment is switched OFF for maintenance operations, the inverter must be physically and safely disconnected, to ensure protection of personnel working on the grid. To prevent possible islanding, the inverter has an automatic protective disconnection system called "Anti-Islanding".

Ground fault in the photovoltaic modules

An advanced ground fault protection circuit continuously monitors the ground connection and disconnects the inverter if a ground fault occurs, indicating this condition by means of the red GFI LED on the LED panel of the CDD. It is required that the CDD be installed with any MICRO inverter in compliance with UL1741, for indicating and resetting ground faults.

Protective devices

The inverter is equipped with additional protective devices to facilitate safe operation. These protective devices include:

- Continuous monitoring of the grid voltage to ensure the voltage and frequency values stay within operating limits;
- Control of internal temperatures to automatically limit the power if necessary to ensure the unit does not overheat (derating).



Efficiency curves

Graphs of the efficiency curves of all the models of inverter described in this manual are shown below. The efficiency curves are linked to technical parameters that are continually being developed and improved and should therefore be considered approximate.

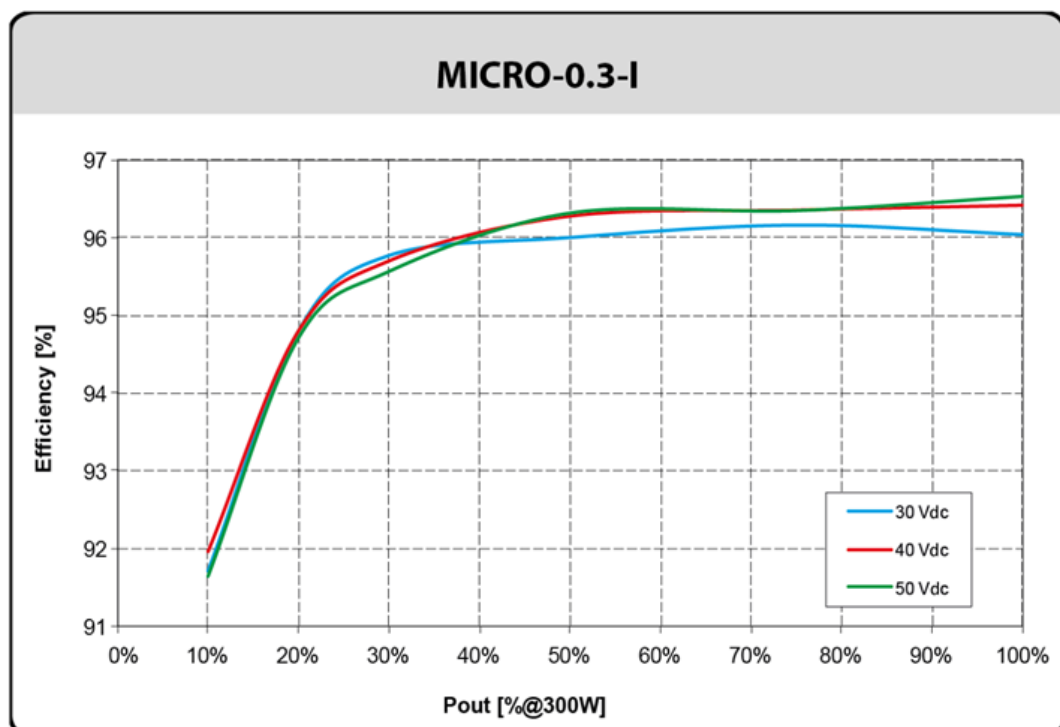
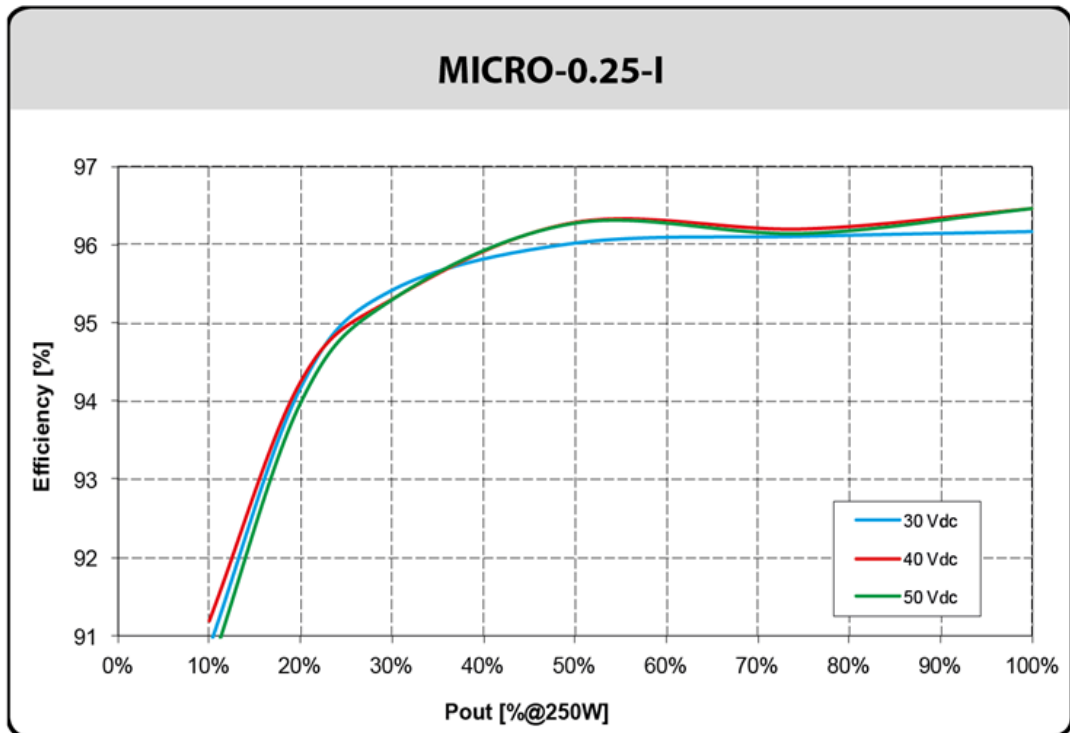

Power reduction curves

In order to allow inverter operation in safe thermal and electrical conditions, the unit automatically reduces the value of the power fed into the grid. Power reduction can take place due to adverse environmental conditions or due to unsuitable input voltage values.

Power reduction due to temperature

Power reduction and temperature at which it occurs depend on many parameters other than ambient temperature, such as input voltage, grid voltage, etc. The inverters can decrease power output during certain periods of the day according to these parameters.

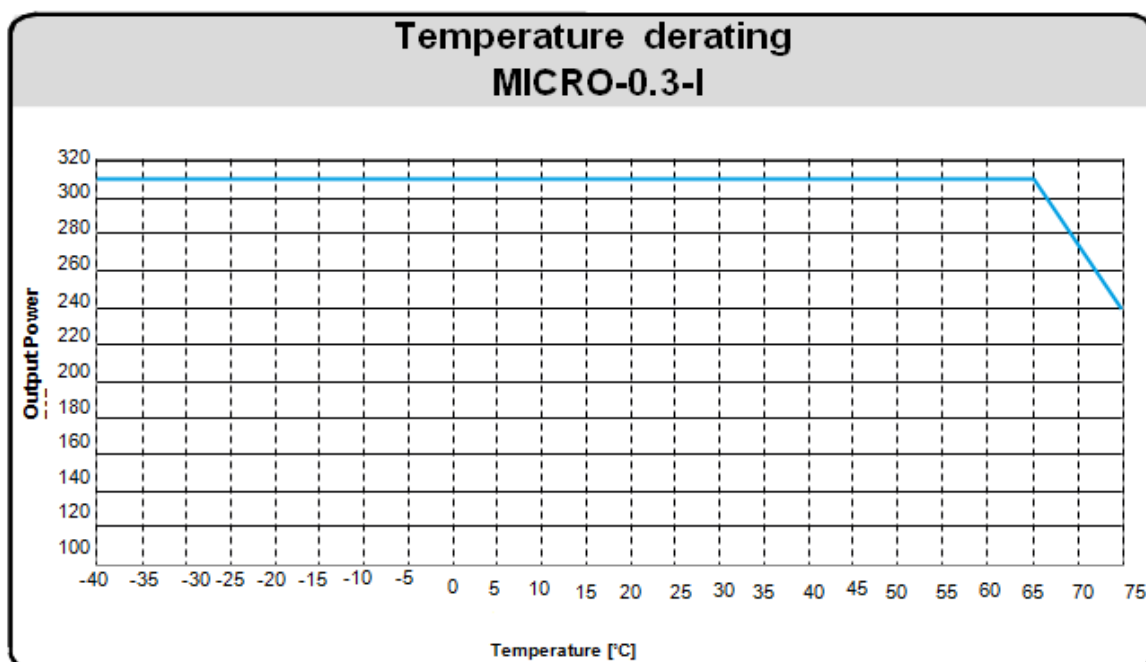
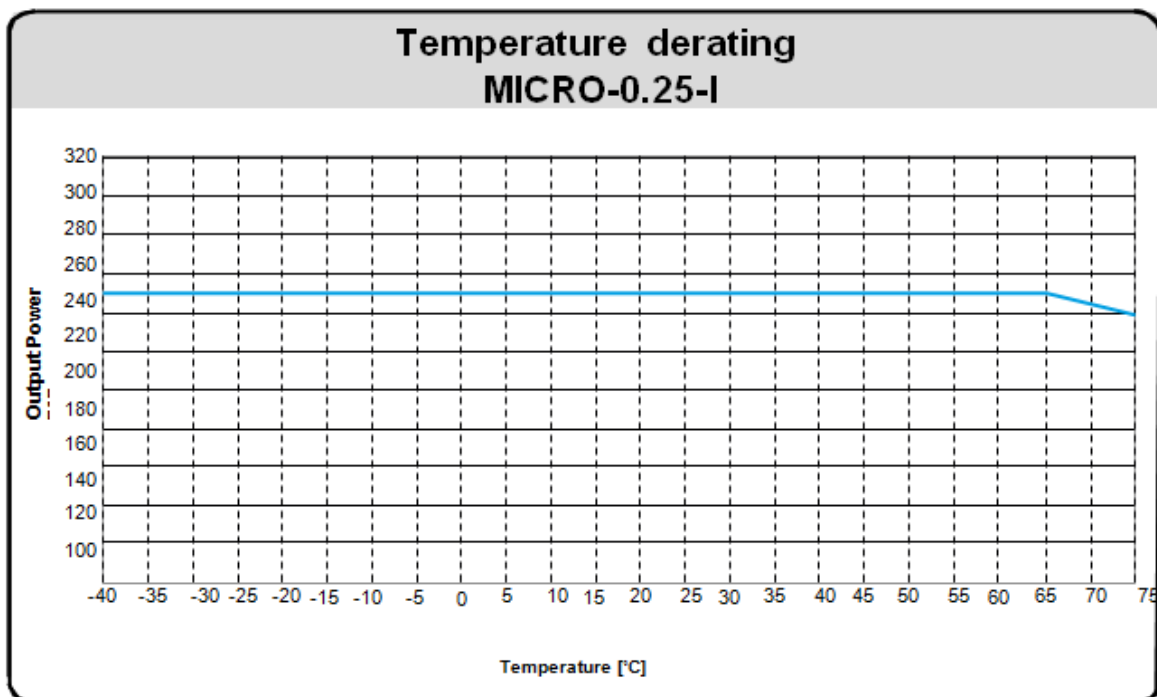

Power reduction due to input voltage

The graphs show the automatic reduction of supplied power when input voltage values are too high or too low.

The conditions for power reduction due to environmental conditions and input voltage can also occur at the same time, but the power reduction will always relate to the lower value measured.

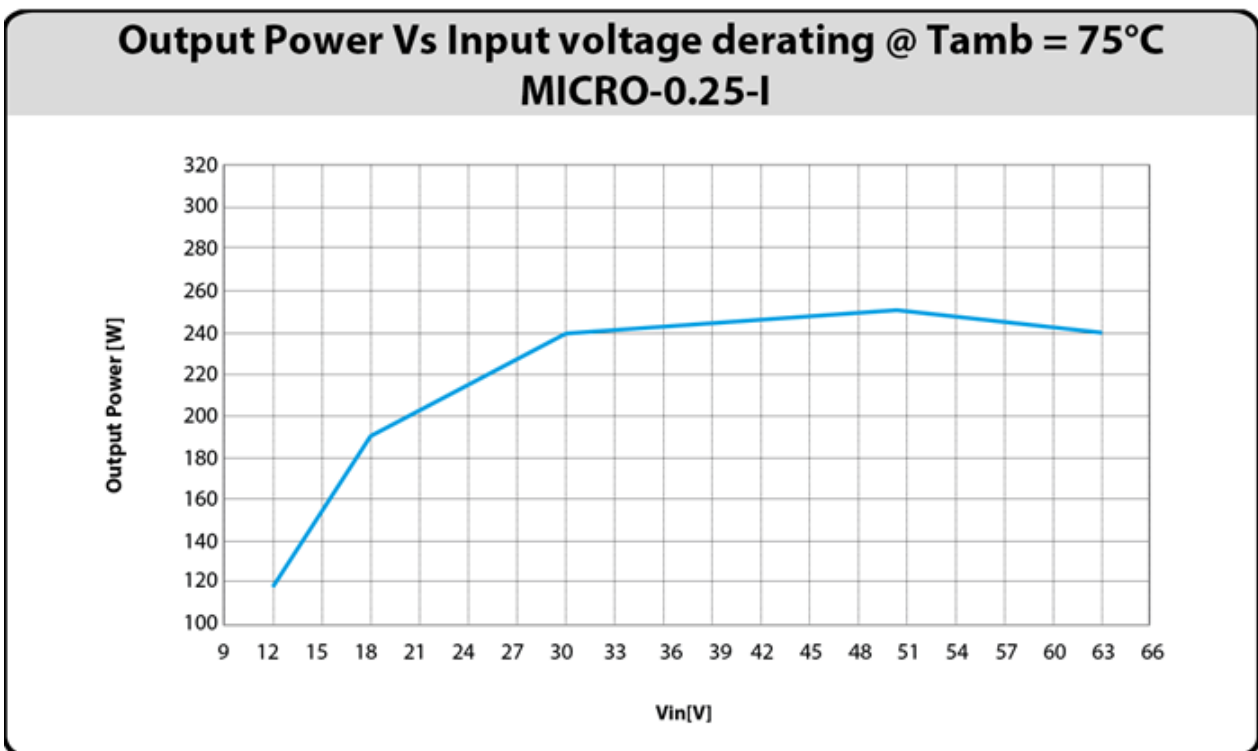
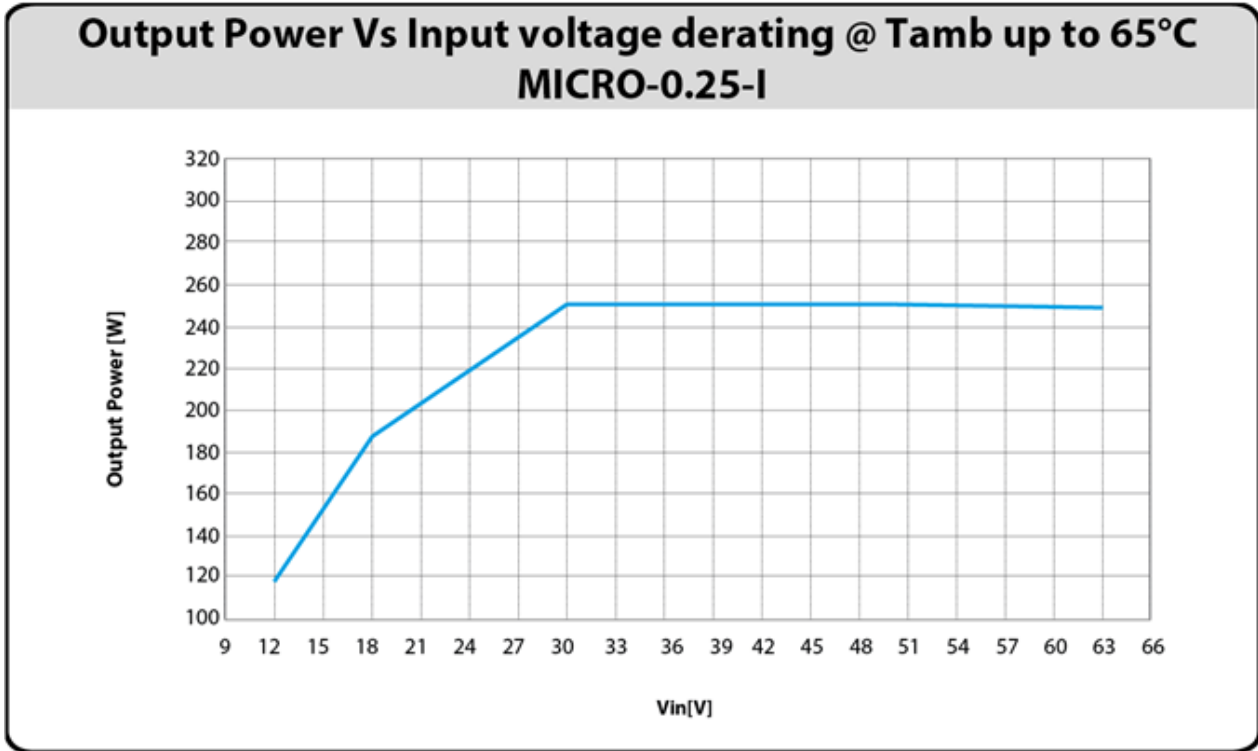

Output Power Vs Input voltage derating @ Tamb up to 65°C MICRO-0.3-I

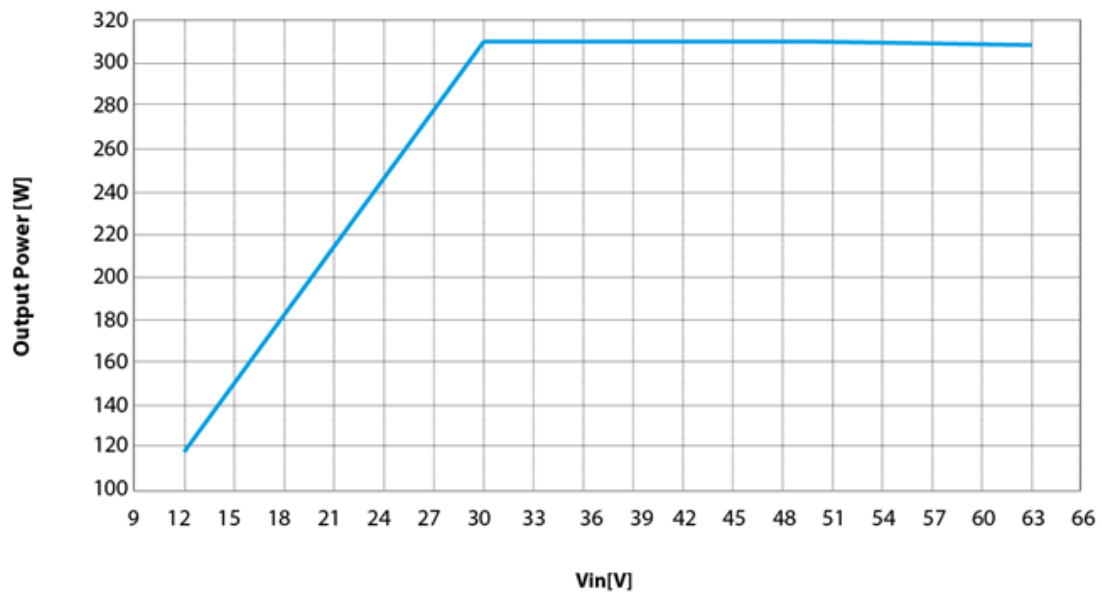

Output Power Vs Input voltage derating @ Tamb = 75°C MICRO-0.3-I

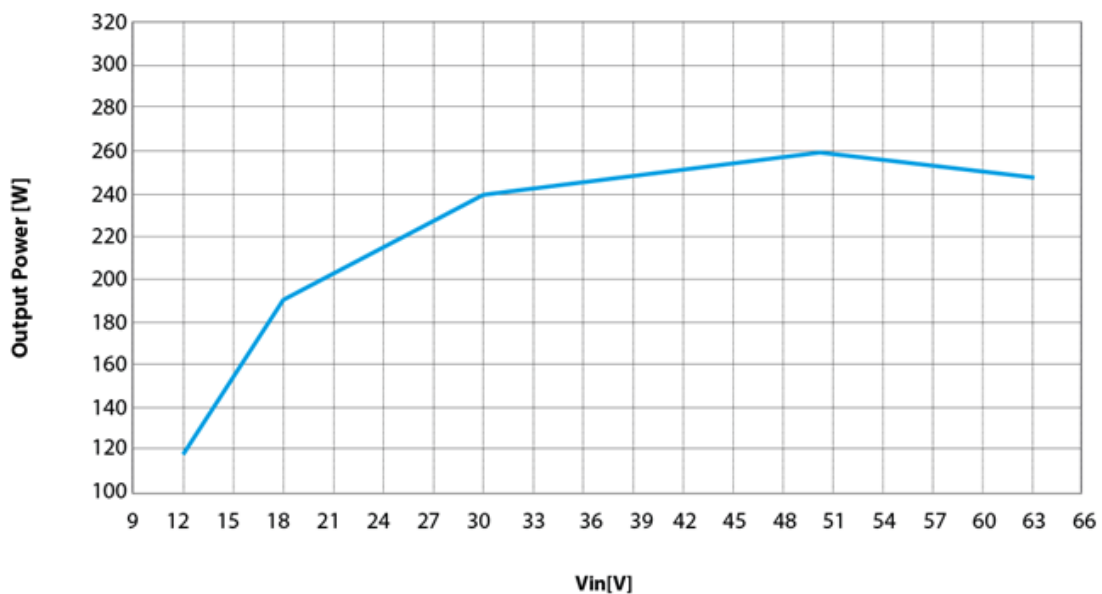

Block diagram

The diagram at right summarizes the layout of the MICRO inverter. The main blocks are the DC-DC input converter (the “boost” section) and the DC-AC output inverter. Both work at a high switching frequency, are small and relatively light.

The inverter is equipped with a single input converter with Maximum Power Point Tracking (MPPT) to which it is possible to connect a single photovoltaic module. This means that the modules connected to the MICRO inverters could be installed in different positions and orientations. This inverter is equipped with a high-frequency transformer, in other words with galvanic isolation of the primary (DC side) from the secondary (AC side), while maintaining very high performance in terms of output and energy export. This type of circuit allows for the grounding of the positive input pole.

The inverter is controlled by two independent DSPs (Digital Signal Processors) and a central microprocessor. The connection to the power grid is thus kept under control by two independent monitors, in full compliance with the electric field norms both for power supply to the systems as well as security.

The wireless communication system inside the MICRO inverter transmits the information to the CDD device that analyzes and manages all system data. All this guarantees optimal operation of the entire unit and high efficiency in all insolation and load conditions, always in full compliance with the relevant directives, standards and provisions.

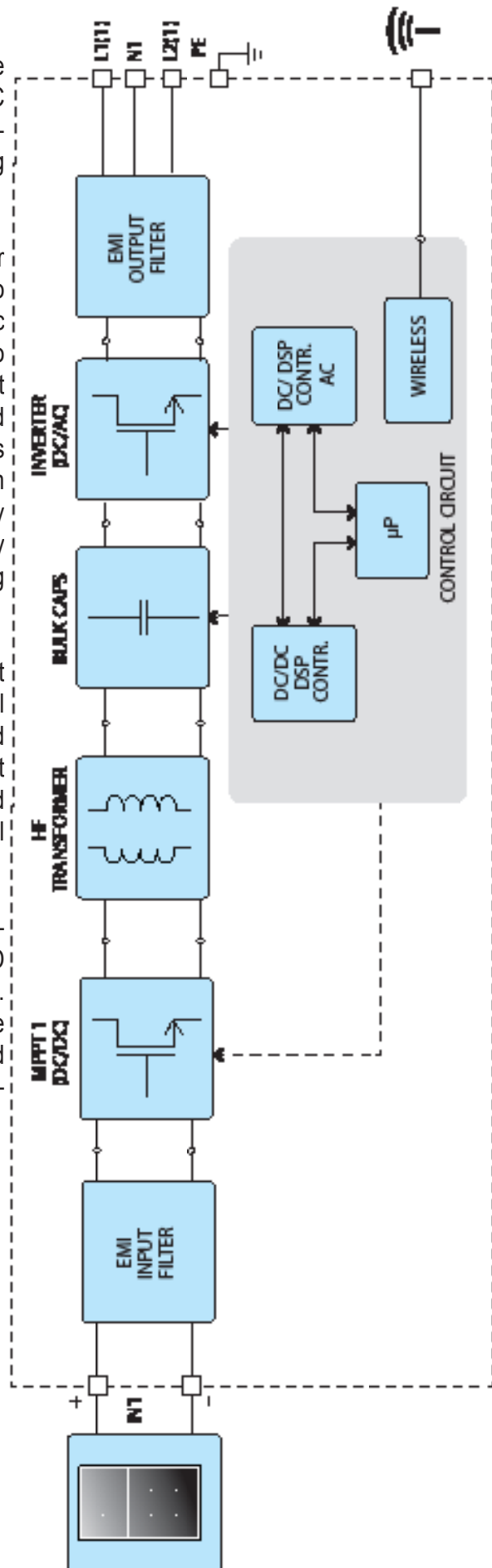

Wiring diagram – 208Vac three phase

If several MICRO inverters are installed in a three-phase AC GRID, it is recommended to distribute the inverters between the phases in order to reduce the power unbalances between the phases. Refer to the local standards.

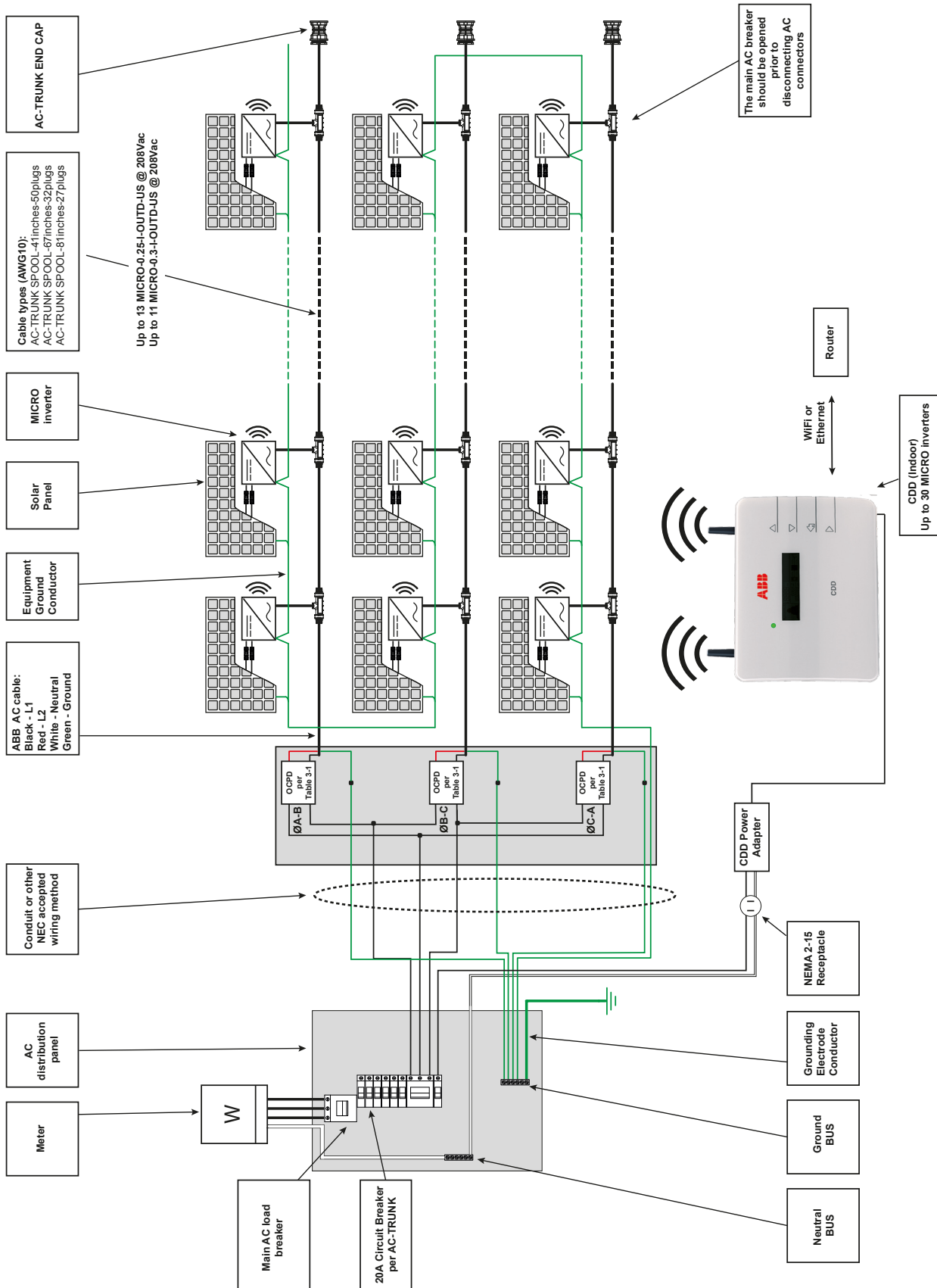

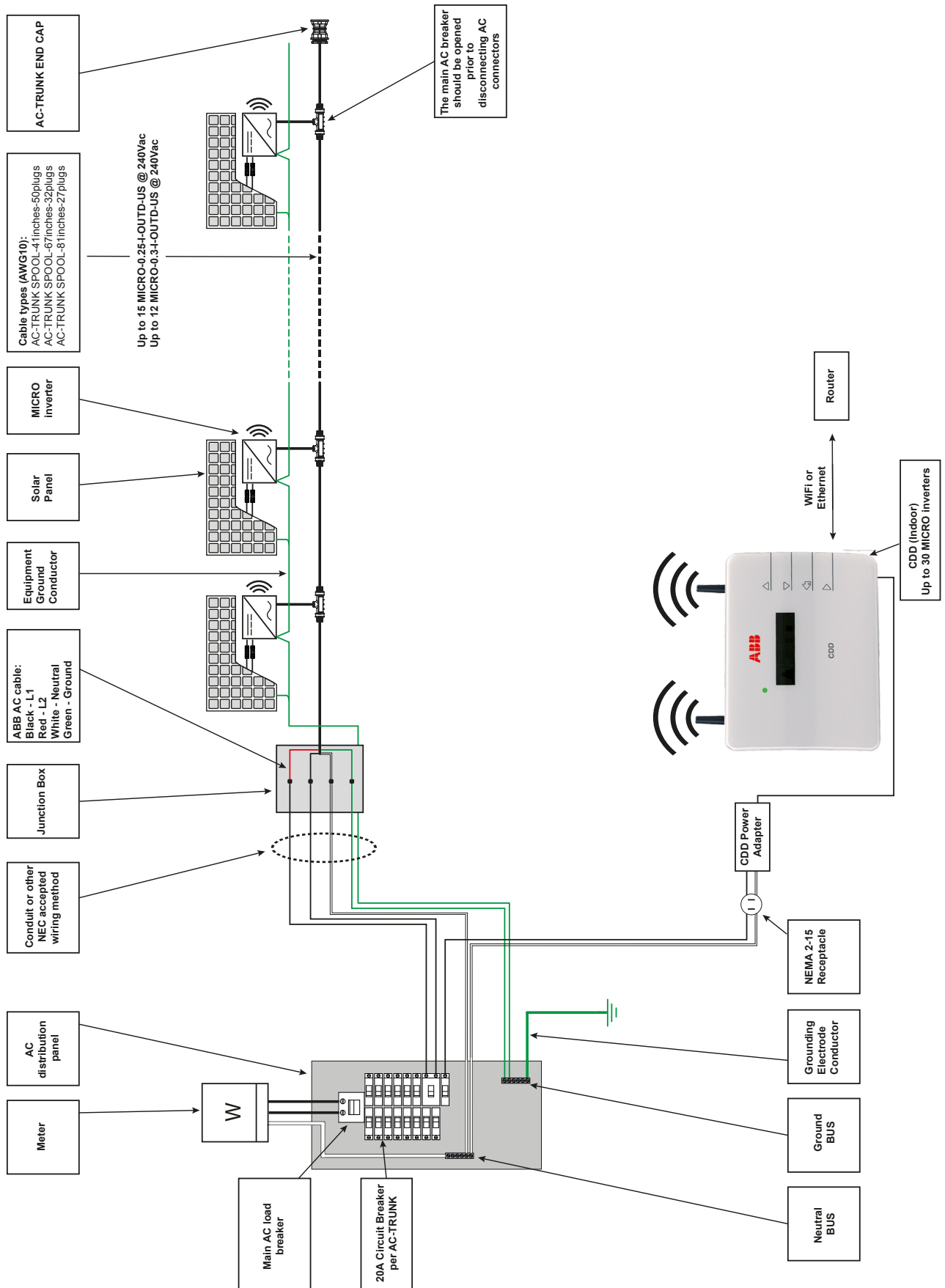

Wiring diagram – 240Vac split phase



Template for system installation diagram



▲ To sheet		▲ To sheet					▼ To sheet		
	1	2	3	4	5				
A									
B									
C									
D									
E									
F									
Azimuth: Tilt: Page ... of ...		Orientation:  °		Affix the detachable label to each field on the map (located on the rear side of the inverter) bearing the serial number of the PVI-MICRO.					

Technical data and types

Type code	MICRO-0.25-I-OUTD		MICRO-0.3-I-OUTD		MICRO-0.3HV-I-OUTD	
Nominal output power	250W		300W ¹		300W ¹	
Rated grid AC voltage	208V	240V	208V	240V	208V	240V
Maximum output power	260W		310W		310W	
Input side (DC)						
Maximum usable DC input power	265 ² Wp		320 ² Wp		320 ² Wp	
Maximum PV panel rating (STC)	300W		360W		360W	
Absolute maximum voltage (Vmax)	65V		65V		79V	
Start-Up voltage (Vstart)	25V		25V		25V	
Full power MPPT voltage range	25-60V		30-60V		30-75V	
Operating voltage range	12-60V ³		12-60V ³		12-60V ³	
Maximum usable current (Idcmax)	10.5A		10.5A		10.5A	
Maximum short circuit current limit	12.5A ³		12.5A ³		12.5A ³	
DC connection type	Amphenol H4 PV connector		Amphenol H4 PV connector		Amphenol H4 PV connector	
Output side (AC)						
Grid connection type	1Ø/2W	Split-Ø/3W	1Ø/2W	Split-Ø/3W	1Ø/2W	Split-Ø/3W
Adjustable voltage range	183V-228V	211V-264V	183V-228V	211V-264V	183V-228V	211V-264V
Nominal grid frequency	60Hz		60Hz		60Hz	
Adjustable grid frequency range	57-60.5 Hz		57-60.5 Hz		57-60.5 Hz	
Maximum output current	1.20A	1.04A	1.44A	1.25A	1.44A	1.25A
Power factor	>0.95					
Maximum number of inverters per string	13	15	11	12	11	12
Grid wiring termination type	18AWG drop cable from inverter to 10AWG AC trunk cable					
Input protection devices						
Reverse polarity protection	Yes; polarized PV connectors (Amphenol H4)					
Output protection devices						
Anti-islanding protection	Meets UL 1741/IEEE1547 requirements					
Over-voltage protection type	Varistor		Varistor		Varistor	
Maximum AC OCPD rating	20A		20A		20A	
Efficiency						
Maximum efficiency	96.5%		96.5%		96.5%	
CEC efficiency	96%		96%		96%	
Operating performance						
Stand-by consumption	<50mW		<50mW		<50mW	
Communication						
Monitoring system	Wireless and web-based monitoring through AURORA CDD (CDD required for compliance to UL1741)					
Environmental						
Ambient air operating temperature range	-40°F to +167°F (-40°C to +75°C) Derating above +149°F (+65°C)					
Ambient air storage temperature range	-40°F to +167°F (-40°C to +80°C)					
Relative humidity	0-100% RH condensing					
Acoustic noise emission level	< 30 db (A) @1m					
Maximum operating altitude without derating	6560 ft (2000 m)					
Mechanical specifications						
Enclosure rating	NEMA 4X					
Cooling	Natural convection					
Dimensions (H x W x D)	10.5 x 9.7 x 1.37in (266 x 246 x 35mm)					
Weight	<3.5lbs (1.65kg)					
Mounting system	Rack mounting with M8, 1/4" or 5/16" bolt					
Safety						
Isolation level	HF transformer					
Safety and EMC standard	UL1741, CSA C22.2 N. 107.1-01, EN61000-6-2, EN61000-6-3, FCC Part 15					
Safety approval	cCSA _{US}					
Warranty						
Standard warranty	10 years					
Available models						
Standard	MICRO-0.25-I-OUTD -US-208/240		MICRO-0.3-I-OUTD- US-208/240		MICRO-0.3HV-I-OUTD- US-208/240	

1. With derating below 200V for 208Vac operation

2. This is the maximum input power that the inverter will utilize

3. Only use PV modules that satisfy these parameters under all operating conditions.



Further information

For more information on ABB products and services for solar applications, navigate to www.abb.com/solarinverters

Contact us

www.abb.com/solarinverters

MICRO-0.25/0.3/0.3HV-I-OUTD-US-208/240 Product Manual
BCG.00612.1_AA (NA REV 1.1)
© Copyright 2014 ABB. All Rights Reserved.