

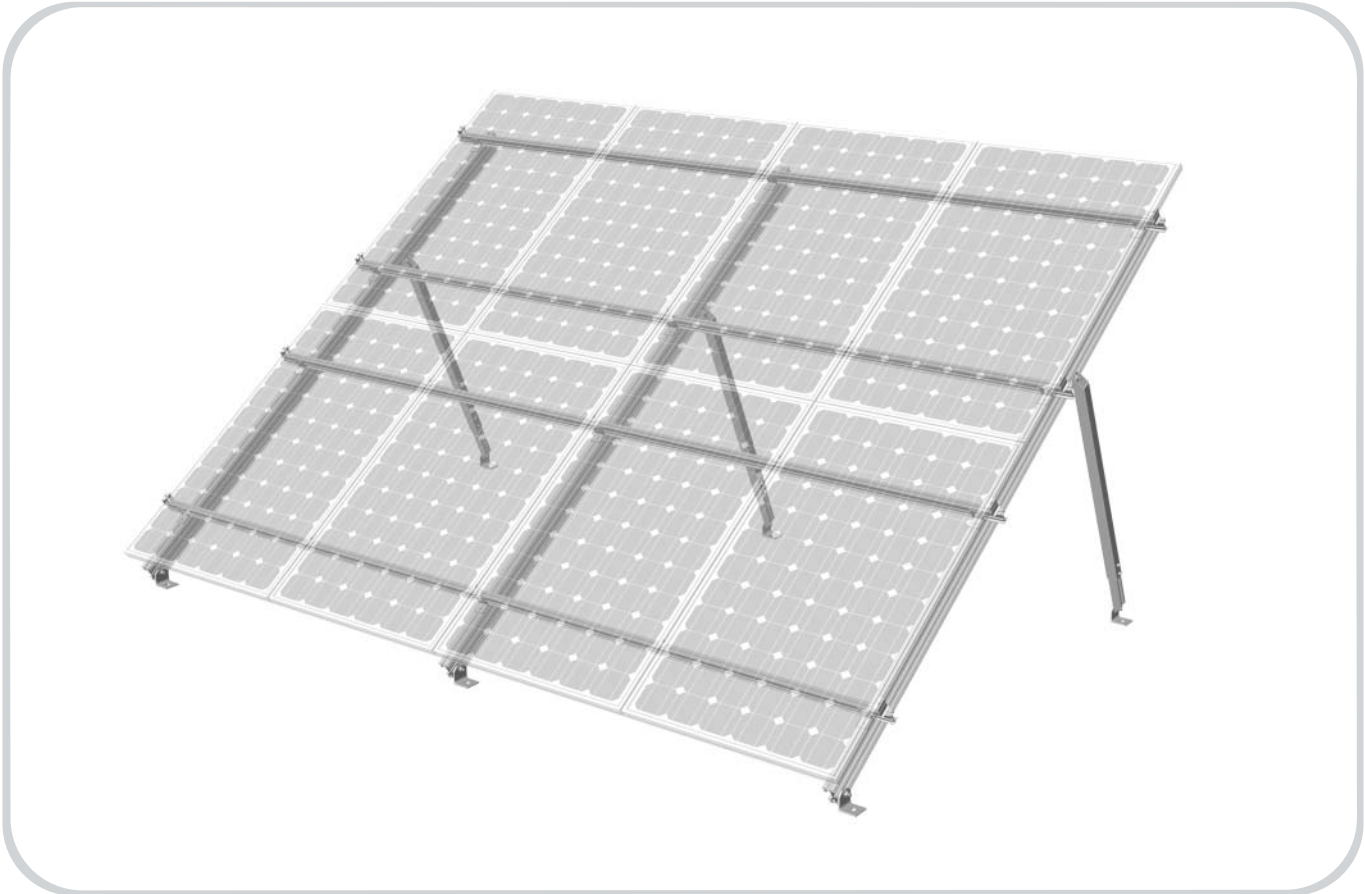

DPW | SOLAR



PREFORMED LINE PRODUCTS



TWO-TIER ROOF/GROUND MOUNT

INCLUDES TELESCOPING & ONE-PIECE LEG TYPES

ASSEMBLY INSTRUCTIONS

step-by-step
assembly and installation



YOUR DPW SOLAR DISTRIBUTOR
SOLARIS
720-474-6050
www.solaris-shop.com

Version 1, Rev A
PCN 020912-1

Two-Tier Roof/Ground Mount

A few words about these Assembly Instructions

These instructions:

- Do not include any information on the selection or installation of attaching hardware to be mounted to the roof substrate or concrete foundation. For information on compatible roof attaching hardware, see our publication titled “Power Rail™ Design Guidelines”.
- Begin after all attaching hardware has been installed and secured to the roof substrate or concrete foundation.
- Are intended to be used by individuals with sufficient technical skills for the task. Knowledge and use of hand tools, measuring devices and torque values is also required.
- Include various precautions in the forms of Notes, Cautions, and Warnings. These are to assist in the assembly process and/or to draw attention to the fact that certain assembly steps may be dangerous and could cause serious personal injury and/or damage to components. Following the step-by-step procedures and these precautions should minimize the risk of any personal injury or damage to components while making the installation an efficient process.

WARNING:

Follow the procedures and precautions in these instructions carefully.

For questions on a specific installation please contact us at:

Phone: 800-260-3792

Email: info@power-fab.com

Required Tools

- 3/4 inch wrench or socket for 1/2 inch hardware
- 1/2 inch wrench or socket for 5/16 inch module clamp hardware
- Torque wrench
- Ratchet wrench
- Ratchet extension bar
- Framing square
- Tape Measure

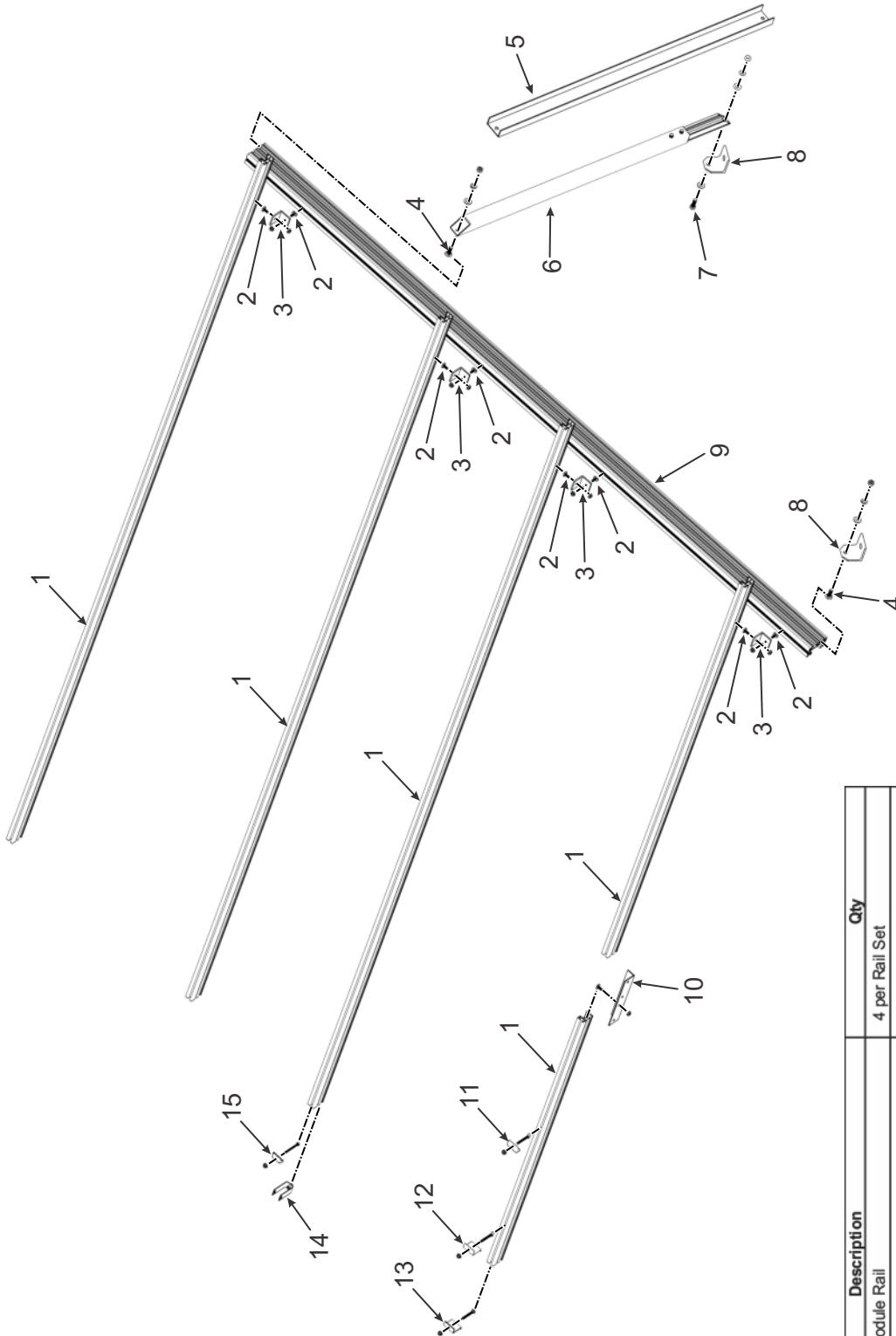

Item	Description	Qty
1	Power Rail P8 Module Rail	4 per Rail Set
2	5/16" x 3/4" turn bolt, flange nut	2 per Rail-to-Rail Bracket
3	Rail-to-Rail Bracket	4 per Strongback
4	1/2" x 1-1/2" carriage bolt, flat washer, lock washer, nut	2 per Strongback
5	One-Piece Leg **	1 per Strongback
6	Telescoping Leg **	1 per Strongback
7	1/2" x 1-1/2" Hex bolt, flat washers, lock washer, nut	1 per leg
8	L-Foot	2 per Leg/Strongback Assembly
9	Power Rail P14 Strongback	1 per leg
10	Splice Plate, set of four (5/16" x 3/4") turn bolts, flange nuts	1 per rail joint
11	RAD Mid-Clamp, (5/16" x *) bolt, flange nut	2 per 3/8" gap between modules

Item	Description	Qty
12	RAD End-Clamp, (5/16" x *) bolt, flange nut	4 per Rail Set
13	End-Clamp, (5/16" x *) carriage bolt, flange nut	4 per Rail Set
14	Universal End Clamp	4 per Rail Set
15	Mid Clamp, (5/16" x *) carriage bolt, flange nut	2 per 3/8" gap between modules

* 2, 2-1/4, 2-1/2, 2-3/4, or 3" bolt. Length is dependent on depth of PV Module frame
 ** Telescoping Leg is standard, One-Piece Leg is optional.
 Notes: 1. Option to install Mid Clamp with carriage bolt or RAD Mid Clamp.
 2. Option to install Universal End Clamp, End Clamp with carriage bolt or RAD End Clamp.

Two-Tier Roof/Ground Mount Parts Identification

Step 1: Measure and Mark L-Foot Location on Strongback

NOTE:
L-Feet can be attached directly to the roof substrate with the proper hardware. See Power Rail Design Guidelines for more information.

L-Feet are attached at the southern ends of the Strongbacks. Being mindful of the Strongback orientation and mounting channels (see Figure 1-1), measure and make a mark at 1" from the end of the Strongback. This is where the center of the L-Foot will be aligned and secured to the Strongback.

- A. Refer to Figure 1-1 for Strongback profile orientation and mounting channel.
- B. From the southern end of the Strongback, measure and make a mark 1" from the end. This is where the Strongback will attach to the southern L-Foot.

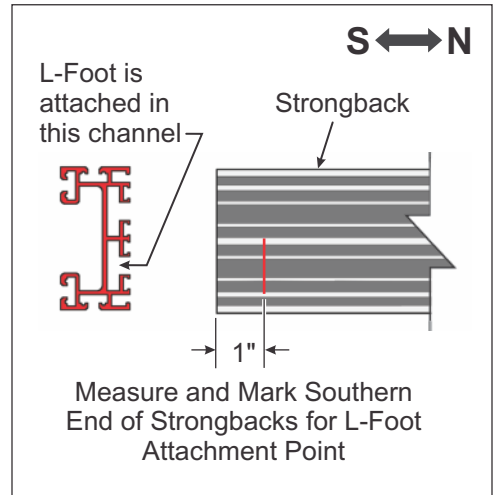

Figure 1-1: Measure and Mark Strongback

Step 2: Attach Strongback to L-Foot

L-Feet are attached to the Strongback with carriage bolts and hardware. (See Figure 2-1)

- A. Insert one 1/2" x 1-1/2" carriage bolt into channel of Strongback and align it to the previously made mark.
- B. Install L-Foot onto carriage bolt and secure with flat washer, lock washer, and 1/2" hex nut. Torque to 45-50 ft.-lbs.

CAUTION:
Span dimensions are a design specification. Consult the design manual to match these dimensions to site conditions. It's important to use the unique span dimension specific to the install. Failure to do so could lead to excessive deflection and/or premature system failure.

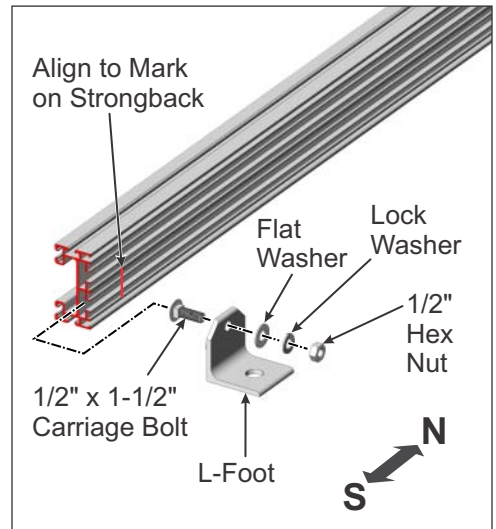

Figure 2-1: Attaching Strongback to Southern L-Foot

Step 3: Attach Leg to Strongback

These instructions cover two types of Legs: Telescoping and One-Piece. The Telescoping is the standard configuration while the One-Piece is optional.

To determine the attachment point of the leg to the Strongback, first refer to the site specific drawings for the distance between the north and south L-Feet. Using this distance, set the angle of the Telescoping or One-Piece Leg so that it provides optimum support of the Strongback (see Figure 3-1). Once this angle is determined, measure the distance between the northern end of the Strongback and the attachment point of the Leg to the Strongback. Measure and mark this attachment point dimension on all the remaining Strongbacks.

CORRECT

Best structural support.
 Angle of Leg is in best position to support Strongback.

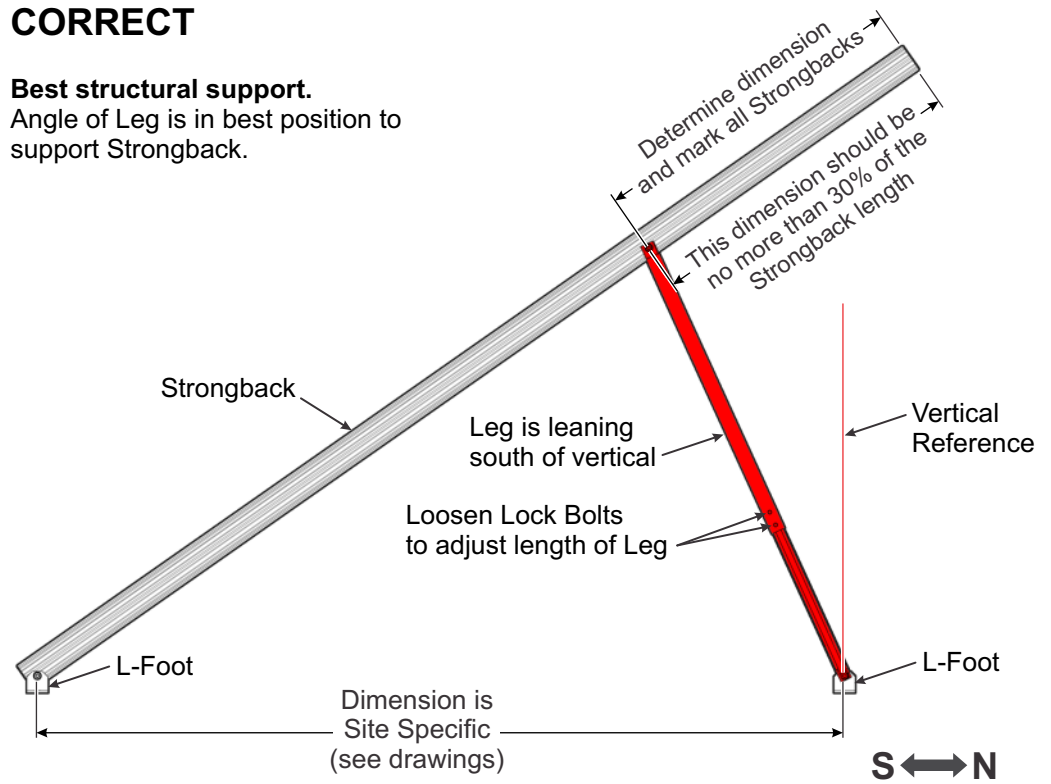

WRONG

Could lead to structural failure.
 Angle of Leg is in poor position to adequately support Strongback.

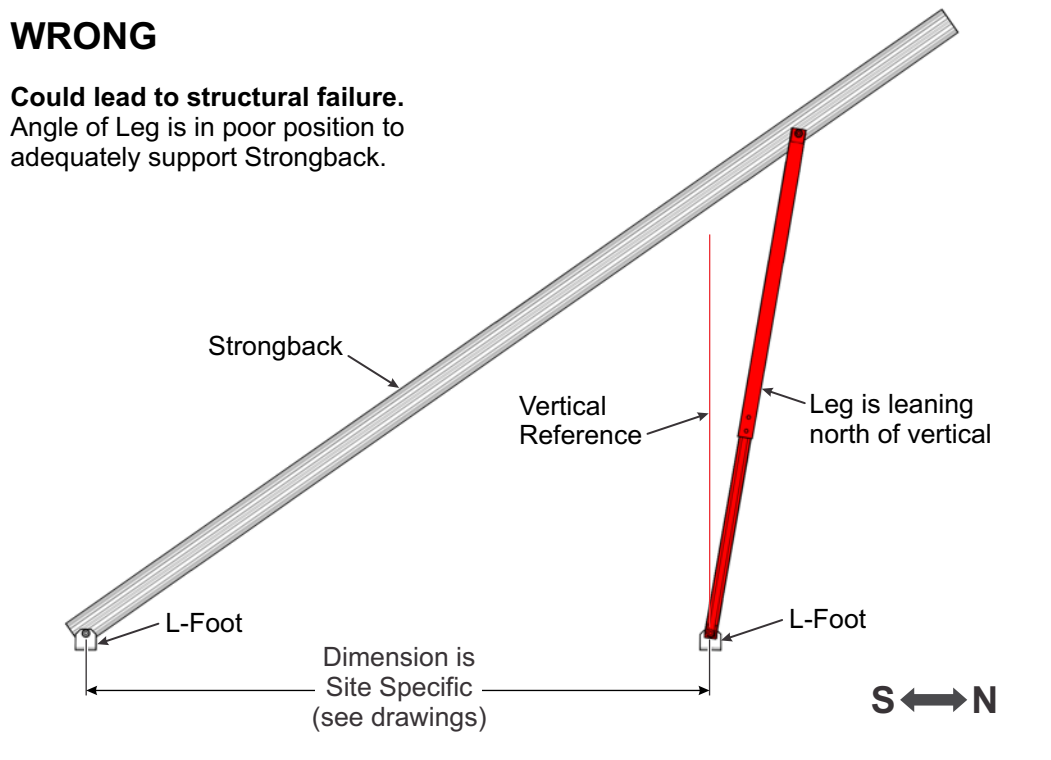

Figure 3-1: Determining Leg Angle and its Attachment Point to the Strongback

The Legs are secured to the Strongback using 1/2" x 1-1/2" carriage bolts and hardware.

WARNING:
This is a two person activity due to the difficulties associated with working on a sloped rooftop. The Strongback and Leg assembly is large and awkward. One person should hold and align the Strongback while a second person secures the leg to the northern L-foot. Failure to do so could lead to serious personal injury and/or damaged components.

- A. Slide 1/2" x 1-1/2" carriage bolt into lower channel of Strongback, aligning bolt with the 14" mark previously made on the Strongback.
- B. Align mounting hole of Leg to carriage bolt and secure with lock and flat washers and 1/2" hex nut. For now, finger tighten only. (See Figure 3-2)

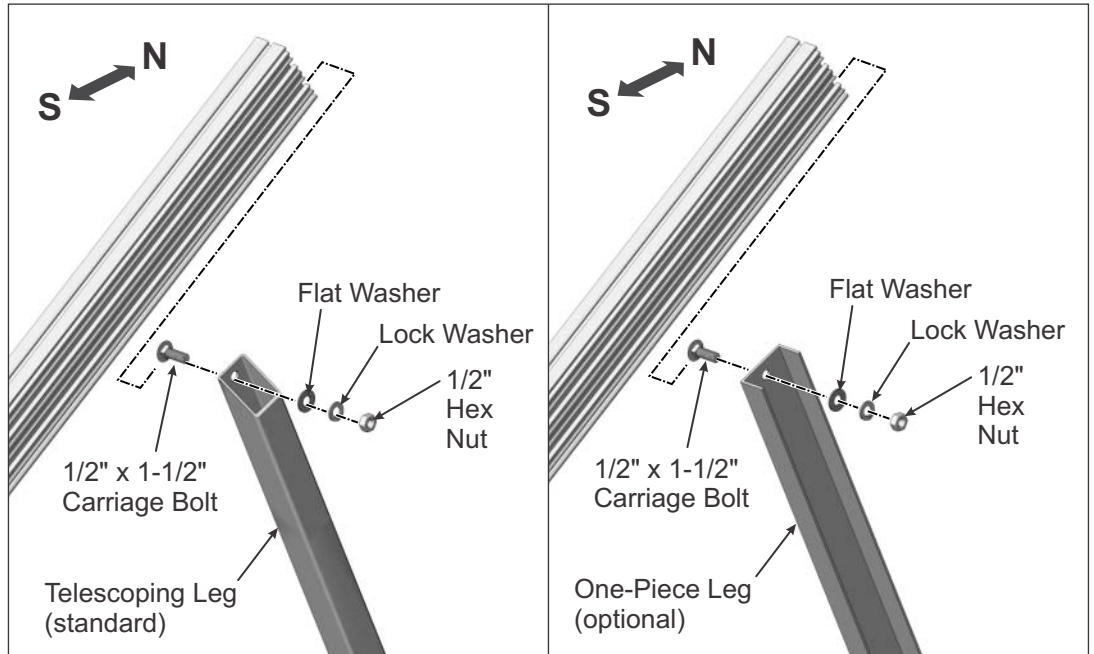

Figure 3-2: Attaching Leg to Strongback

Step 4: Attach Legs to Northern L-Feet

Legs are attached to the northern L-Feet using a 1/2" hex bolt and hardware.

- A. Raise northern end of Strongback and align mounting hole of Leg to hole of northern L- Foot. Secure with 1/2" x 1-1/2" bolt, flat washers, lock washer and nut.

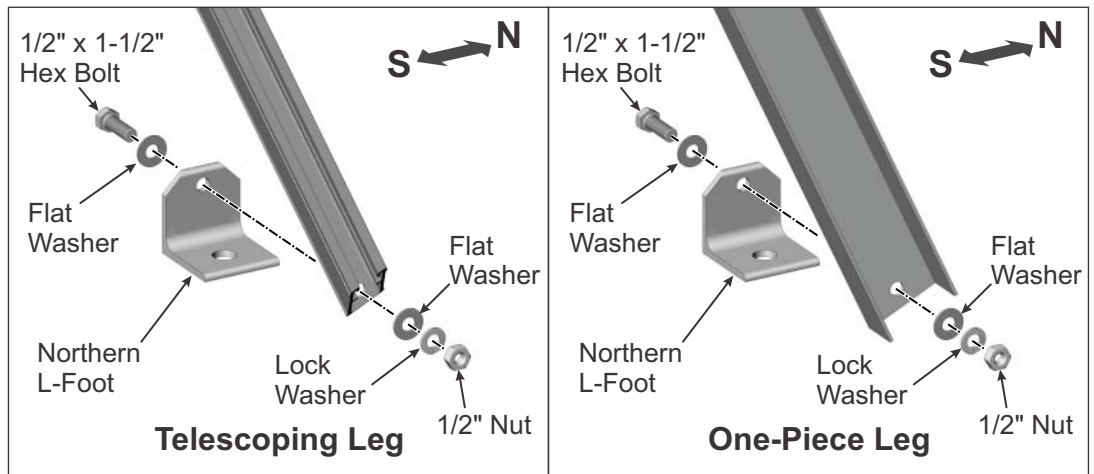

Figure 4-1: Attaching Leg to Northern L-Foot

- B. Go back and check that the Leg and the southern L-Foot position haven't shifted from their marks on the Strongback. Adjust to align as needed.
- C. Return to tighten and torque hardware as follows:
 - 1/2" hardware securing Strongback to L-Foot: **Torque to 45-50 ft.-lbs.**
 - 1/2" hardware securing Leg to Strongback: **Torque to 45-50 ft.-lbs.**
 - 1/2" hardware securing Leg to L-Foot: **Torque to 45-50 ft.-lbs.**
 - 5/16" Telescoping Leg lock bolts: **Torque to 14-16 ft.-lbs.**

Step 5: Installing Rail-to-Rail Brackets

Power Rails™ attach to the Strongbacks via Rail-to Rail mounting brackets and 5/16" x 3/4" turn bolts and flange nuts. The N-S span of the Rail-to-Rail brackets on the Strongback is dependent on the type/size of module being used. If the module manufacturer has provided specific clamping locations, use those specifications; if none are specified by the manufacturer, use a factor of 20-percent of the module length to determine the N-S span of the Rail-to-Rail brackets. (See Figure 5-1)

Once the span is determined, measure and mark the positions of the Rail-to-Rail brackets on each of the Strongbacks.

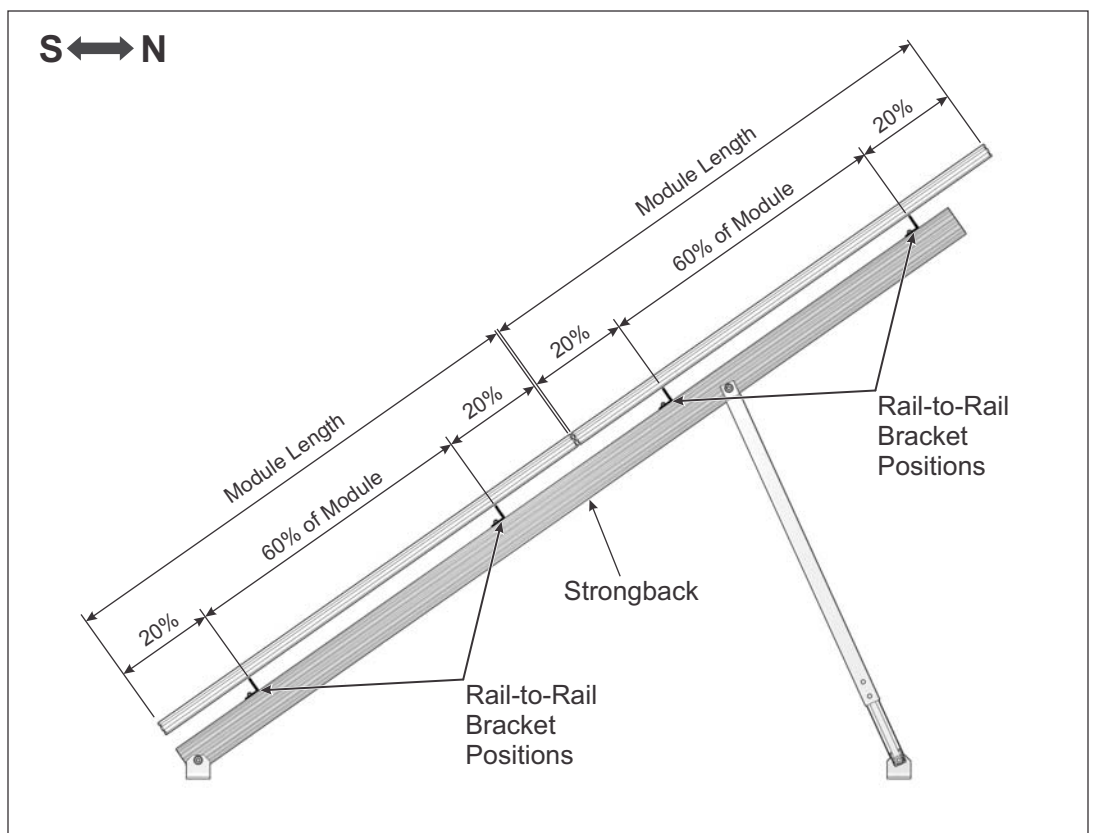

Figure 5-1: Positioning the Rail-to-Rail Brackets on the Strongback

NOTE:

Use care in aligning the Rail-to-Rail brackets from one Strongback to the next. This will greatly assist in the installation of the Power Rails.

NOTE:

Turn bolts must be locked into the channel by rotating clockwise 90-degrees. Use the indicator slot on the threaded end to identify whether or not the bolt has been locked.

Turn bolt shown in channel of Power Rail

Locked



Indicator Slot shown in Red

Align and install the Rail-to-Rail brackets to the marks made on the Strongback. (See Figure 5-2)

- A. Slide 5/16" x 3/4" turn bolt into the Power Rail.
- B. Install Rail-to-Rail bracket on turn bolt. Position bracket to its location on the Strongback. Secure with 5/16" flange nut. **Torque to 14-16 ft.-lbs.**

Continue in this manner installing all Rail-to-Rail brackets on remaining Strongbacks before installing the Power Rails.

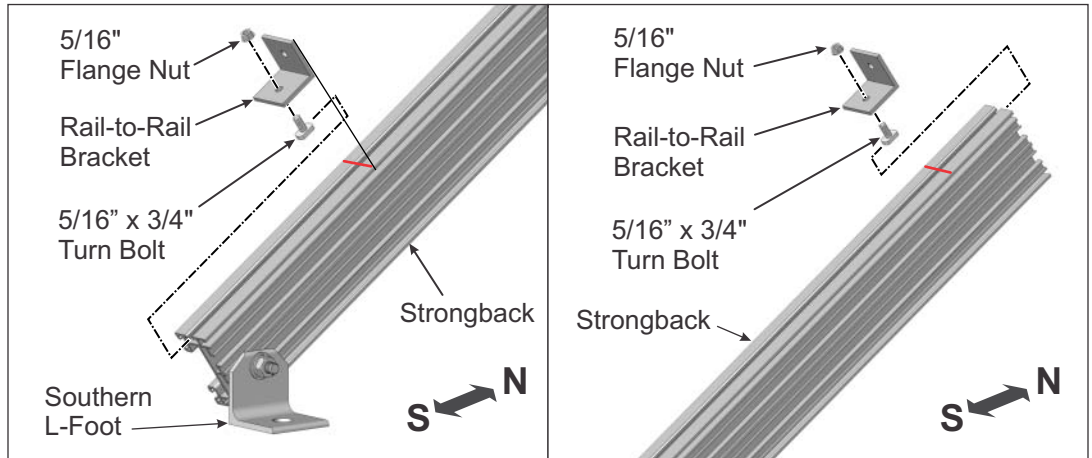

Figure 5-2: Southern & Northern Rail-to-Rail Bracket Installation

Step 6: Splicing Power Rail with Splice Plates

In some cases, the overall length of a rail set may require the use of a Splice Plate to butt joint two lengths together. Splice Plates are mounted on the sides of the Power Rail. The steps below describe the installation of a Splice Plate.

- A. Insert appropriate quantity of 5/16" x 3/4" turn bolts (two on P6, four on P8) into the channel of each section of rail to be spliced.
- B. Hold the butt-joint closed.
- C. Position the Splice Plate on the Power Rail and turn bolts.
- D. Align the Splice Plate so that it's equally divided along the Power Rail butt-joint.
- E. Twist and lock the turn bolts into the channel and secure with 5/16" flange nuts. **Torque to 14-16 ft.-lbs.**

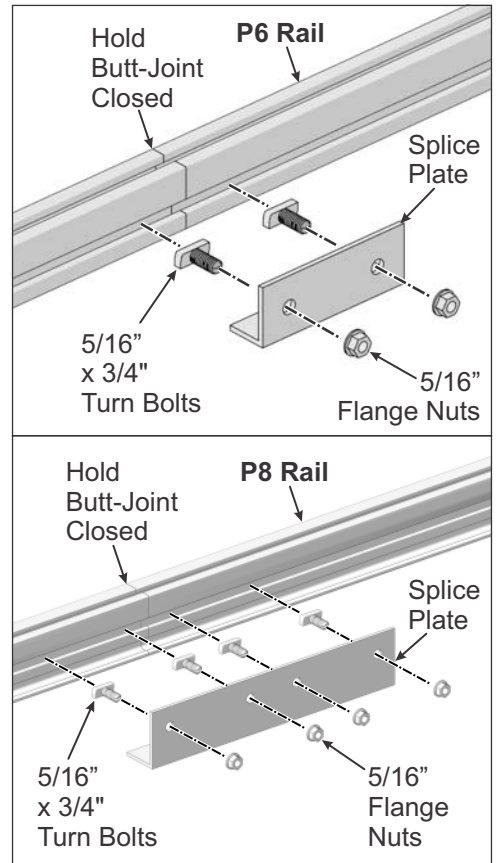

Figure 3-1: P6 or P8 Splice Plate Installation

Step 7: Installing Power Rails

Power Rails attach to the Rail-to-Rail brackets using 5/16" x 3/4" turn bolts and flange nuts. While installing, pay close attention to the orientation between the Power Rail and the Rail-to-Rail brackets. Additionally, refer to the job specific plans for the E-W positioning of the Power Rail along the Strongbacks. In most cases, the run of the Power Rail is centered over the Strongbacks.

- A. Position the southern Power Rail to the north side of the Rail-to-Rail brackets with the Power Rail profile in the same orientation as shown in Figure 7-1.
- B. Referring to the *Power Rail Design Guidelines*, set the E-W position of the Power Rail in relation to the Strongbacks by following the maximum allowable spans and cantilevers required for your site conditions.
- C. Insert one each of the 5/16" x 3/4" turn bolts into the Power Rail channel for each of the Rail-to-Rail brackets along the run of Power Rail.
- D. Align each turn bolt to its respective Rail-to-Rail bracket, twist and lock the turn bolt, and secure with 5/16" flange nuts. **Torque all at 14-16 ft.-lbs.**

Install each of the remaining Power Rails in the same manner.

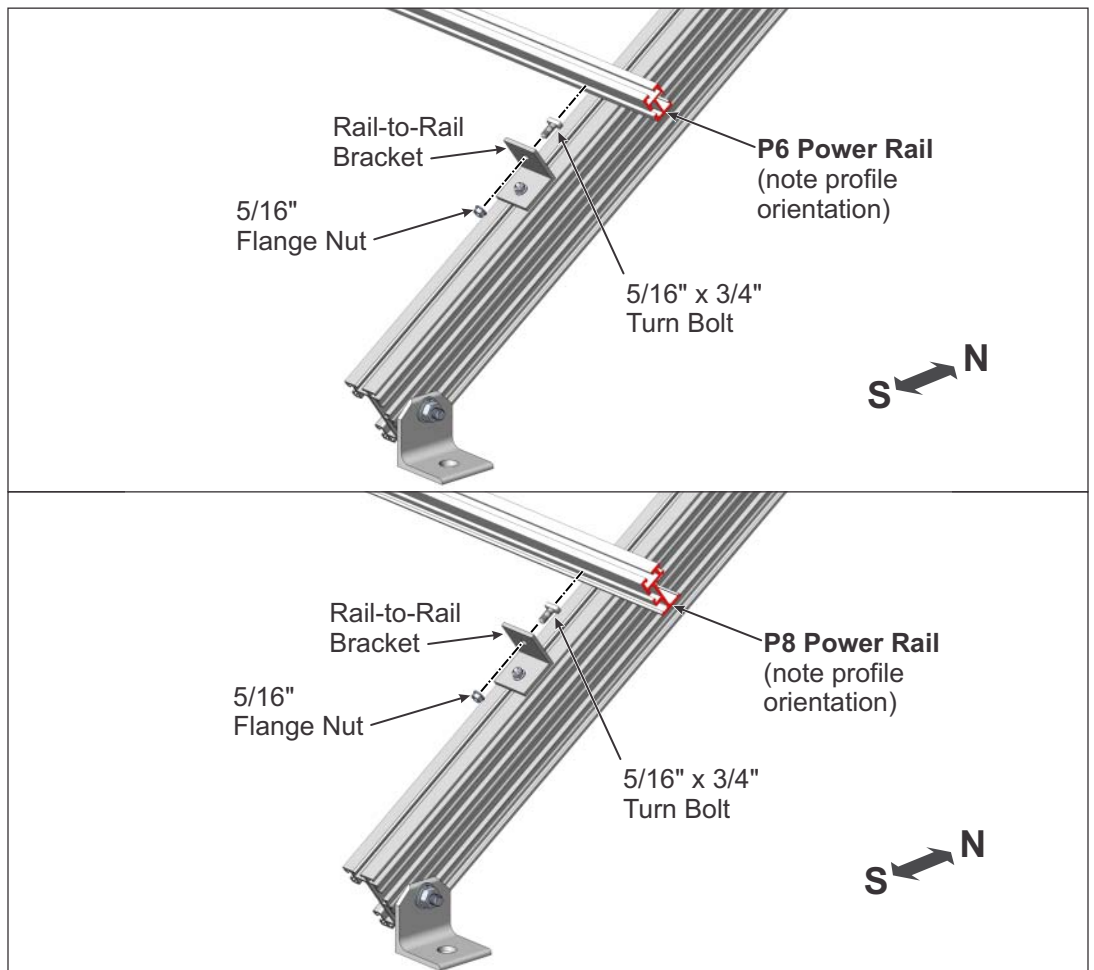

Figure 7-1: Installing P6 or P8 Power Rails

Step 8: Installing PV Modules to Power Rails with Module Clamps

WARNING:

This is a two person activity. In addition to the difficulties associated with working on a sloped rooftop, PV Modules are heavy. One person should hold and align the modules while a second person secures modules with clamping hardware. Failure to do so could lead to serious personal injury and/or damaged components.

WARNING:

Modules must be held in place until they are secured at all four points with clamping hardware. Failure to do so could lead to serious personal injury and/or damaged components.

PV Modules are secured to the Power Rail using Mid Clamps (Standard or RAD™) and End Clamps (Standard, RAD or Universal), along with the appropriate attaching hardware.

Attaching hardware includes Carriage Bolts or RAD Bolts for Mid Clamps and End Clamps, while the Universal End Clamp includes a preassembled Hex Bolt.

The importance of correctly installing End and Mid Clamps:

There is only one correct method of installing End Clamps and Mid Clamps. Failure to follow the correct method could lead to personal injury, structural failure, and/or damaged components. See Figure 8-1 for proper method of installation for an End Clamp and Figure 8-2 for the Mid Clamp. Refer to these figures during the installation of the Modules to prevent any problems associated with an improper installation.

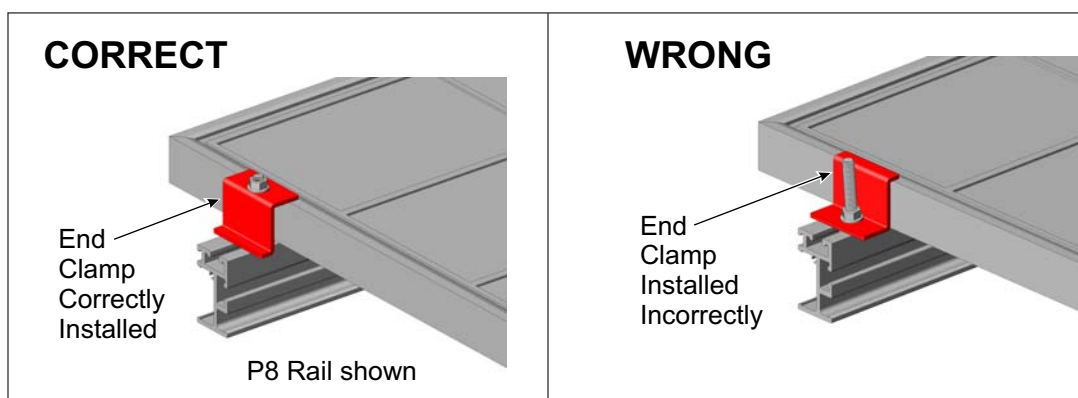

Figure 8-1: Correct and Wrong methods of installing Standard End-Clamp (using Carriage or RAD Bolts)

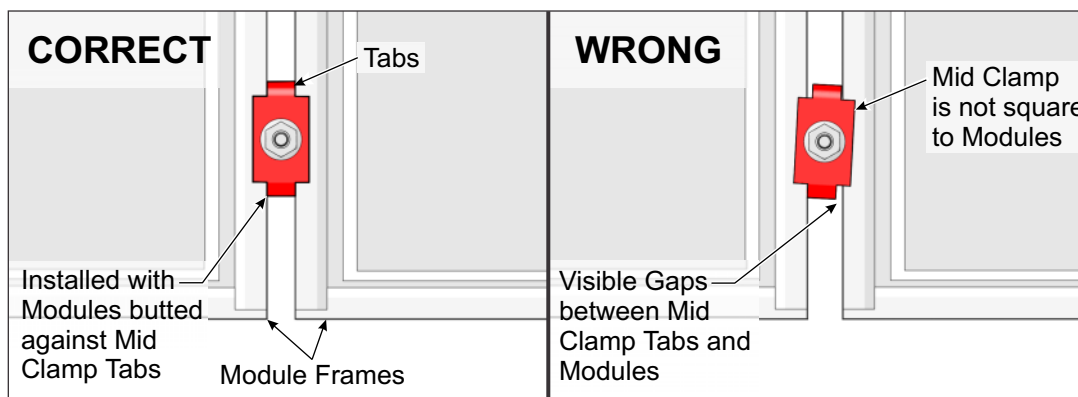

Figure 8-2: Correct and Wrong methods of installing a Mid Clamp (using Carriage or RAD Bolts)

Installing Modules using Standard End and Mid Clamps:

Start with exterior Module and End Clamps.

- A. Place Module on two Power Rails, centering it lengthwise. Use a square to square-up the Module to the Power Rails.
- B. Insert one 5/16" x 2, 2-1/4, 2-1/2, 2-3/4, or 3" carriage bolt into the top slot of the Power Rail. Push the bolt against the side of the module frame. Install End Clamp onto bolt and secure with 5/16" flange nut. **Torque to 14-16 ft.-lbs.** (See Figures 8-1 and 8-3)

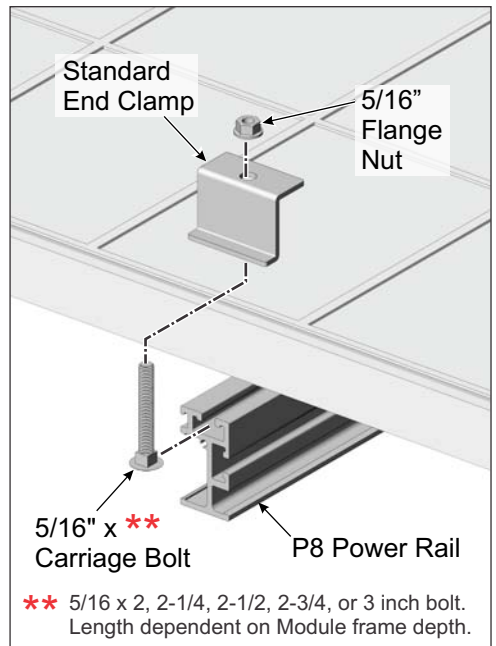

Figure 8-3: Installing Modules using Standard End-Clamp

Now install the next in-line Module using Mid Clamps.

- C. Before placing the interior Module onto the Power Rails, first insert 5/16" x 2, 2-1/4, 2-1/2, 2-3/4, or 3" carriage bolts (bolt length is dependent on depth of Module frame) into the Module Rail, sliding the bolts inward next to the previously installed exterior Module. (See Figure 8-4)

NOTE: Hardware is dependent on particular features and system design. Therefore, it may appear different from these instructions.

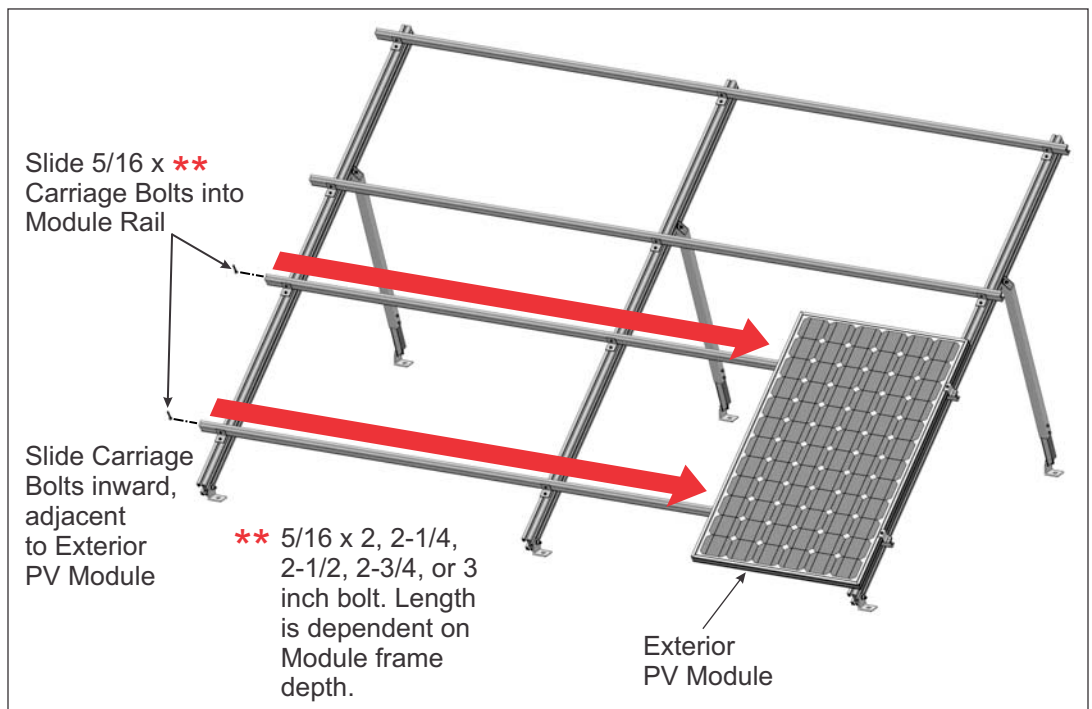

Figure 8-4: Inserting Mid Clamp Hardware into Power Rail

NOTE:

If using standard 5/16" carriage bolts for Mid Clamps, they must be inserted into Power Rail before installing interior PV Modules.

If using RAD hardware, they can be inserted anytime at any position along the Power Rail.

- D. Install a Mid Clamp onto each carriage bolt making certain that the Mid Clamp tabs rest between the two modules.
- E. Push Modules against Mid Clamp tabs and secure Mid Clamp with 5/16" flange nut. **Torque to 14-16 ft.-lbs.** (See Figures 8-2 and 8-5)

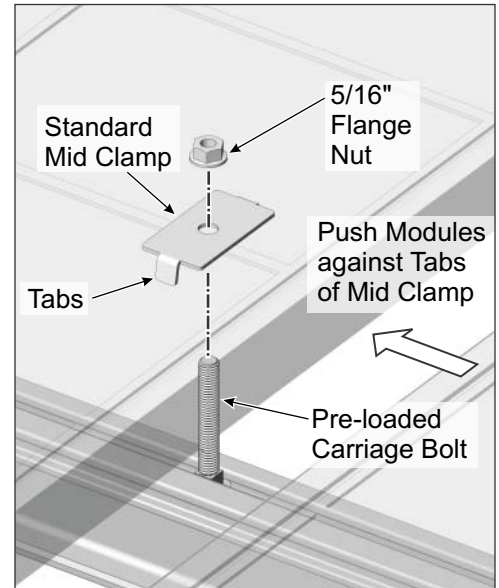

Figure 8-5: Installing Modules using Standard Mid Clamp

Installing Modules using RAD End and Mid Clamps:

Start with exterior Module and End Clamps.

- A. Place Module on two Power Rails, centering it lengthwise. Use a square to square-up the Module to the Power Rails.
- B. Insert one 5/16" x 2, 2-1/4, 2-1/2, 2-3/4, or 3" RAD bolt into the top slot of the Power Rail. Push the bolt against the side of the module frame and twist to lock in place. Install End Clamp onto bolt and secure with 5/16" flange nut. **Torque to 14-16 ft.-lbs.** (See Figures 8-1 and 8-6)

Install next in-line Module using Mid Clamps.

- C. Insert one 5/16" x 2, 2-1/4, 2-1/2, 2-3/4, or 3" RAD bolt (bolt length is dependent on depth of Module frame) into each Rail, next to the previously installed exterior Module. Twist RAD bolt to lock in place. (See Figure 8-7)

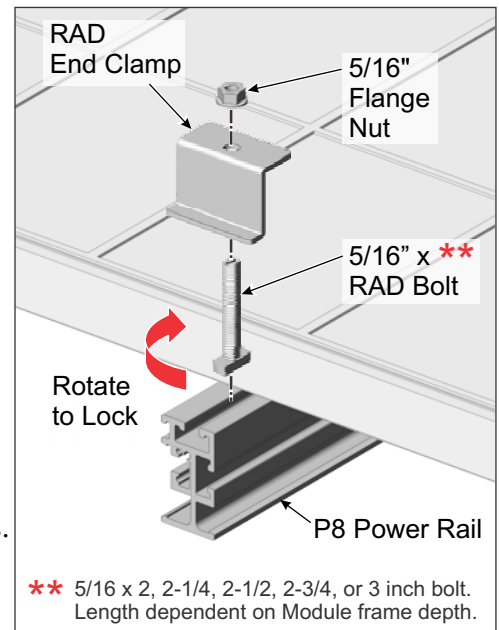

Figure 8-6: Installing Modules using RAD End Clamp

- D. Place next Module onto Rails.
- E. Install a Mid Clamp onto each RAD bolt making certain that the Mid Clamp tabs rest between the two modules.
- F. Push Modules against Mid Clamp tabs and secure Mid Clamp with 5/16" flange nut. **Torque to 14-16 ft.-lbs.** (See Figures 8-2 and 8-7)

Installing Modules using Universal End Clamps:

- A. Place Module on two Power Rails, centering it lengthwise. Use a square to square-up the Module to the Power Rails.
- B. Position Universal Clamp underneath the module with notches facing the outside edge of the module, and rail centered between 'forks' of the clamp. Slide clamp notches towards the module flange until the flange bottoms out in the notches. Tighten 5/16" bolt on bottom of universal end clamp. **Torque to 14-16 ft.-lbs.** Repeat for both end clamps. (See Figure 8-8)

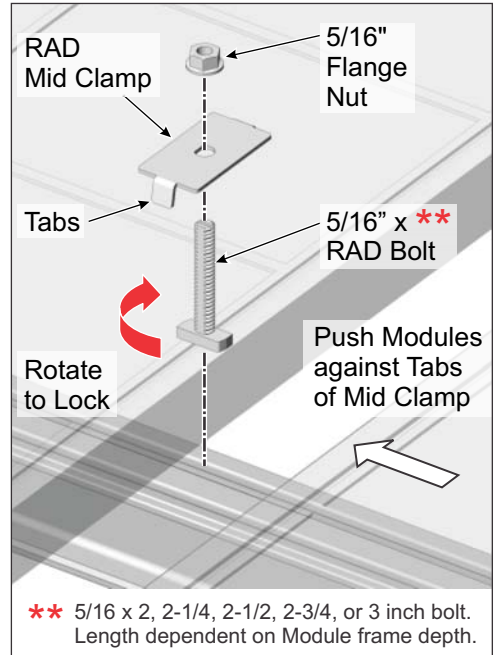

Figure 8-7: Installing Modules using RAD Mid Clamp

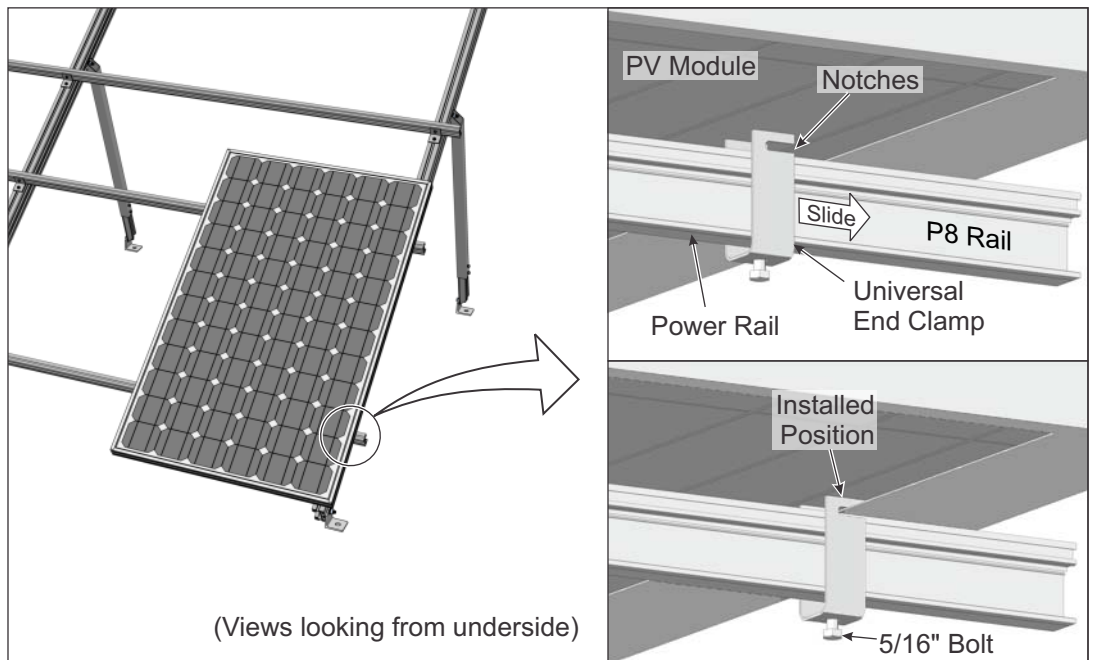

Figure 8-8: Installing PV Modules using Universal End Clamp

Step 9: Adjusting Tilt Angle with Telescoping Legs

WARNING:

Be certain that all Flange Nuts on End and Mid Clamps are tightened and torqued to the stated values. Failure to do so could lead to serious personal injury and/or damaged components and property.

The Telescoping legs are designed to easily adjust the tilt angle of an array. It is recommended that this procedure be done by a minimum of two people. After loosening specific hardware, the full array pivots from the southern L-Feet.

WARNING:

It's very important to support the weight of the array during this procedure. A minimum of two people should be used to hold and support the array while a third person loosens and retightens the hardware. Failure to do so could lead to serious personal injury and/or damaged components and property.

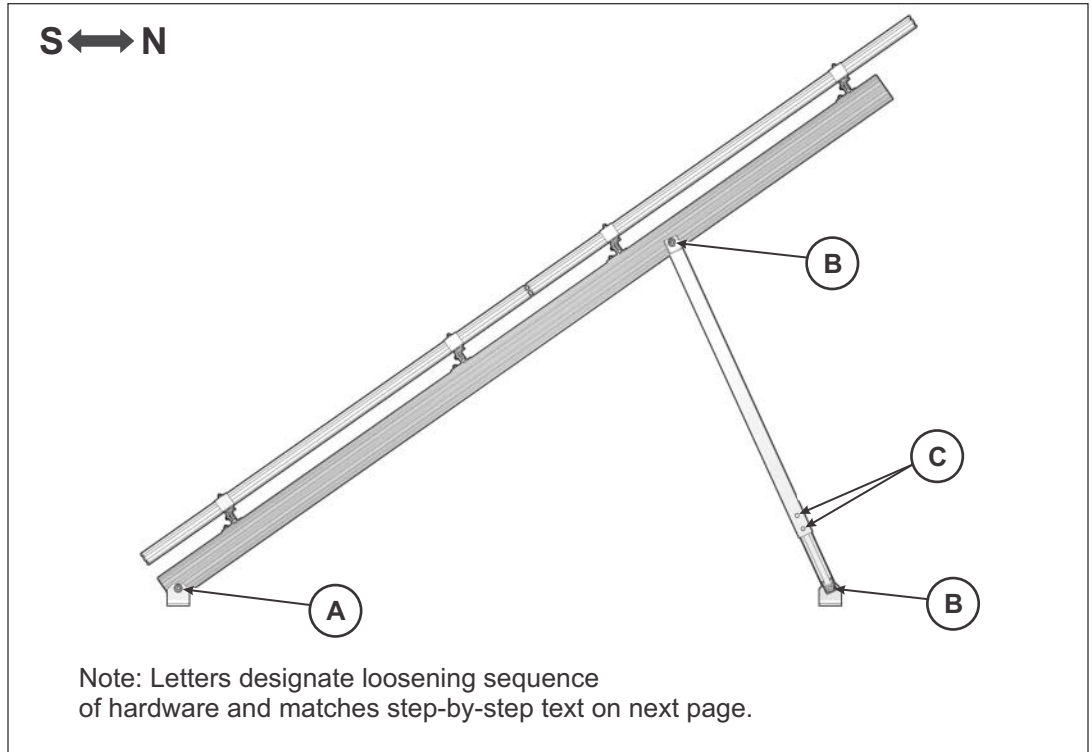

Figure 9-1: Adjusting Tilt Angle

Use caution when loosening hardware to avoid disengaging them from their locations. Loosen just enough to allow components to rotate freely (See Figure 9-1).

- A. Begin by loosening the hardware attaching the Strongbacks to the L-Feet.
- B. As two people hold and support the array from the backside, the third person loosens the hardware at both ends of the Telescoping Legs.
- C. Now loosen the Telescoping Leg lock bolts.
- D. Lift/push the array to the desired tilt angle and hold in place.
- E. Re-tighten and torque hardware as follows (See Figure 9-2):
 1. 5/16" Telescoping Leg lock bolts: **Torque to 14-16 ft.-lbs.**
 2. 1/2" Nuts securing Legs to Strongback: **Torque to 45-50 ft.-lbs.**
 3. 1/2" Hardware securing Legs to L-Foot: **Torque to 45-50 ft.-lbs.**
 4. 1/2" Nuts securing Strongbacks to L-Foot: **Torque to 45-50 ft.-lbs.**

WARNING:

Be certain that all hardware has been retightened and torqued to the stated values. Failure to do so could lead to serious personal injury and/or damaged components and property.

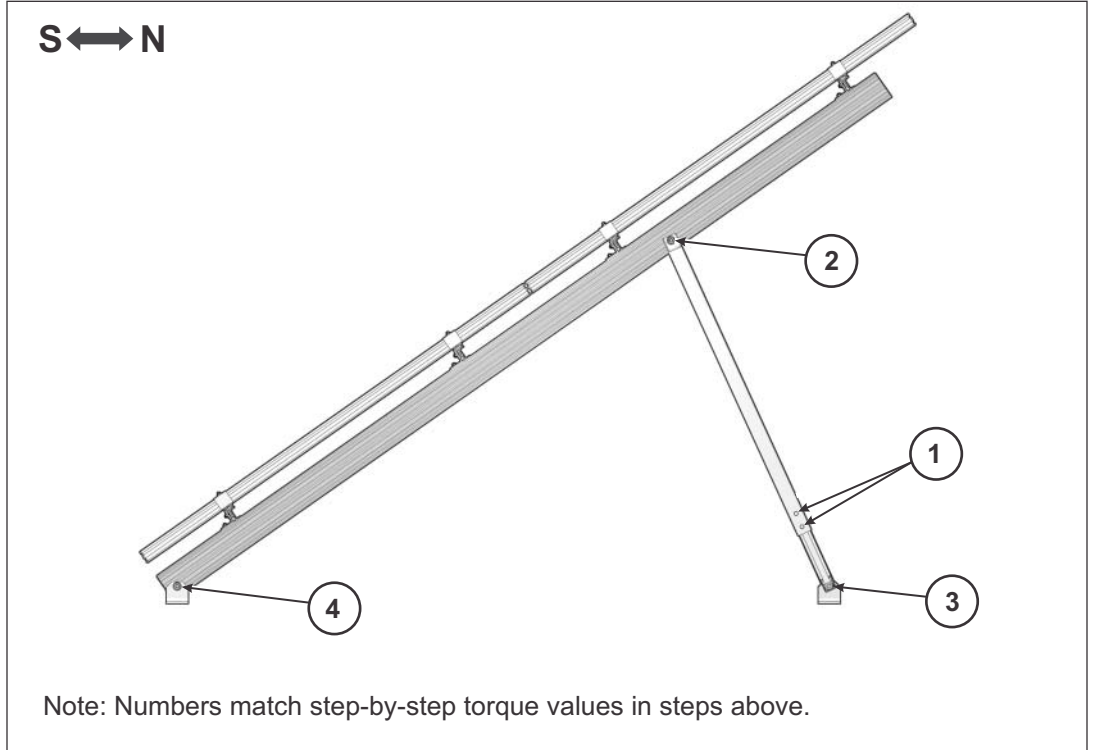

Figure 9-2: Retighten and Torque Hardware



Direct Power & Water Corporation
4000-B Vassar Drive NE
Albuquerque, New Mexico 87107
USA

Telephone: 800.260.3792
Fax: 505.889.3548
Web Site: www.DPWSolar.com
E-mail: info@power-fab.com

Preformed Line Products
(Canada) Limited
1711 Bishop St. E
Cambridge, ON N1T 1N5

Telephone: 519.740.6666
Fax: 519.740.7917
Web Site: www.preformed.on.ca
E-mail: sales@preformed.on.ca