

GROUND MOUNT

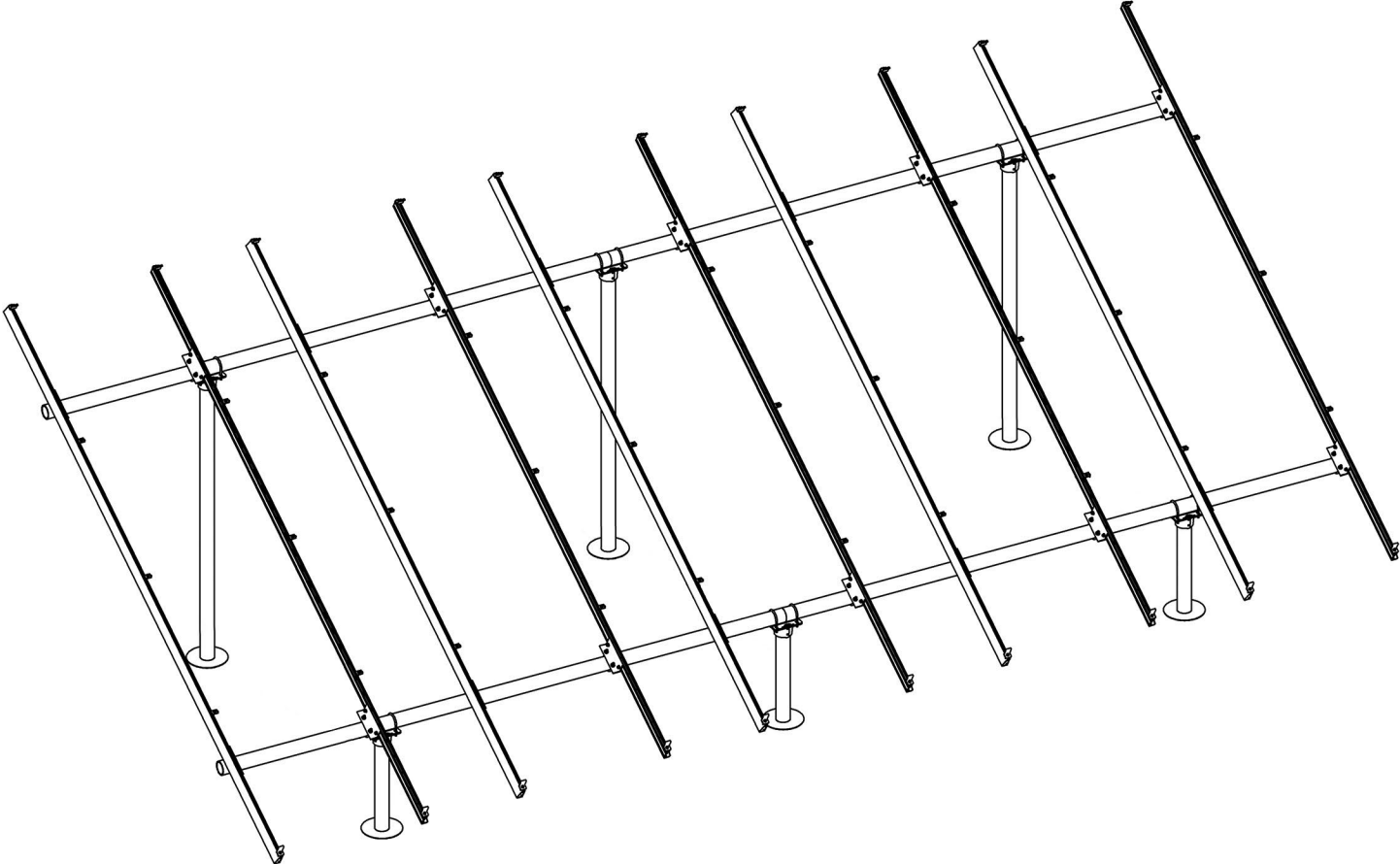

CONTENTS

DISCLAIMER	1
CHECKLIST	2
1. BUILD BASE	3
2. CONNECT SUBSTRUCTURE	3
3. PLACE RAILS	4
4. SECURE LUGS	4
5. CLAMP MODULES	5
DIAGONAL BRACES (OPTIONAL)	6
UNDER CLAMPS (OPTIONAL)	6
END CAPS (OPTIONAL)	6
WIRE CLIPS (OPTIONAL)	6
WARRANTY	7

DISCLAIMER

This manual describes the proper installation procedures and provides necessary standards required for product reliability and warranty. All installers must thoroughly read this manual and have a clear understanding of the installation steps and procedures prior to installation. Failure to follow these guidelines may result in property damage, bodily injury or even death.

IT IS THE INSTALLER'S RESPONSIBILITY TO:

- Ensure that the installation is completed by a licensed solar professional.
- Comply with all applicable local or national building codes, including any that may supersede this manual.
- Ensure all products are appropriate for the installation, environment, and array under the site's loading conditions.
- Use only IronRidge parts or parts recommended by IronRidge; substituting parts may void any applicable warranty.
- Review the [Design Assistant](#), [Engineering Design Guide](#), and [Certification Letters](#) to confirm design specifications.
- Comply with all applicable fire codes including, but not limited to, keeping walkways clear and avoiding obstacles.
- Ensure provided information is accurate. Issues resulting from inaccurate information are the installer's responsibility.
- Confirm with the module manufacturer that Ground Mount is compatible with the selected module.
- Validate foundation parameters prior to installation, as a local geotechnical report may be required to assess ground conditions. We recommend consulting with a local engineer familiar with local regulations and build site requirements, including soil conditions, terrain and load criteria. All parameters may impact foundation requirements.
- Ensure safe installation of all electrical aspects of the array. All electrical installation and procedures should be conducted by a licensed and bonded electrician or solar contractor. All work must comply with national, state and local installation procedures, product and safety standards.

CHECKLIST

PRE-INSTALLATION

- Verify module compatibility with Ground Mount.
- Purchase 2" or 3" schedule 40 steel pipe (ASTM A53 Grade B) or mechanical tubing (Allied Flo-Coat and Gatorshield) for structure.
- Verify that needed components have been obtained. Contact your local distributor for any additional parts.

TOOLS REQUIRED

- Post Hole Digger or Powered Auger
- Socket Drive (7/16", 9/16", and 1/2" Sockets)
- Torque Wrenches (0-240 in-lbs and 10-40 ft-lbs)
- Transit, String Line, or Laser Level
- 3/16" Allen Head

TORQUE VALUES

- Top Cap Set Screws (3/8"-16)
Schedule 40 Pipe: 240 in-lbs
2" Allied Mechanical Tubing: 132 in-lbs
3" Allied Mechanical Tubing: 192 in-lbs
- Top Cap U-Bolt Nuts (3/8"-16): 180 in-lbs
- Rail Connector Bracket Nuts (3/8"-16): 204 in-lbs
- Rail Connector U-Bolt Nuts (3/8"-16): 60 in-lbs
- Grounding Lug Nuts (1/4"-20): 120 in-lbs
- Grounding Lug Set Screws (1/4"-20): 84 in-lbs
- End Clamp Nuts (1/4"-20): 84 in-lbs
- Standard Mid Clamp Nuts (1/4"-20): 120 in-lbs
- Grounding Mid Clamp Nuts (1/4"-20): 84 in-lbs (55 in-lbs for SunPower Modules)
- Diagonal Brace Hardware (1/2"-13): 480 in-lbs
- Under Clamp Nuts (1/4"-20): 120 in-lbs

PRIMARY COMPONENTS

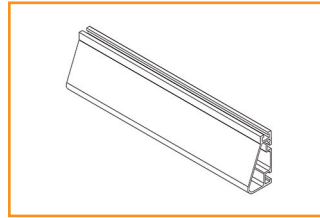

XR1000 Rails
Aluminum

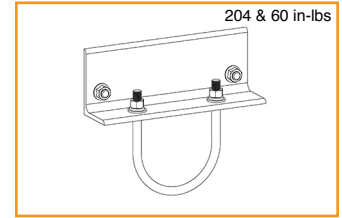

204 & 60 in-lbs
Rail Connectors
Aluminum

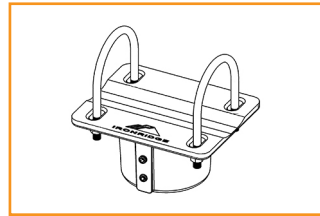

Top Caps
Aluminum

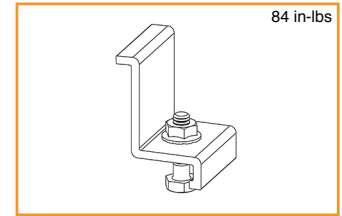

84 in-lbs
End Clamps
Aluminum

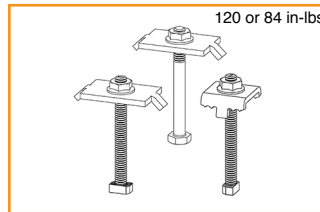

120 or 84 in-lbs
Mid Clamps
Aluminum

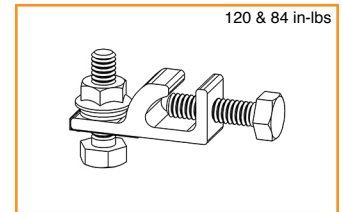

120 & 84 in-lbs
Grounding Lugs
Tinned Copper & SS

SECONDARY COMPONENTS



Wire Clips
Polycarbonate

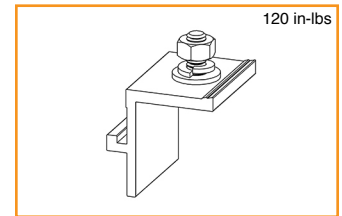

120 in-lbs
Under Clamps
Aluminum



End Caps
Polycarbonate

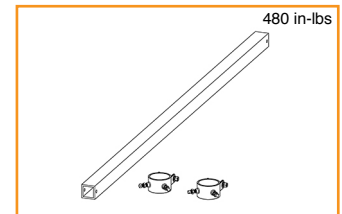

480 in-lbs
Diagonal Braces
Aluminum

1. BUILD BASE

A. MARK LOCATIONS

Establish pier locations. Once grid of pier locations has been set, verify all angles are square.

- ☑ Spacing varies with load conditions. Consult engineering specs.

B. POSITION PIERS

Excavate for foundations, insert vertical piers, and pour concrete foundations. Make sure vertical piers are plumb, level, and square, in parallel rows, evening tops with level.

- ☑ For concrete foundations, brace piers until cured.
- ☑ In some cases, cross bracing is required to provide extra support for piers. If required, install [Diagonal Braces](#) at this time.

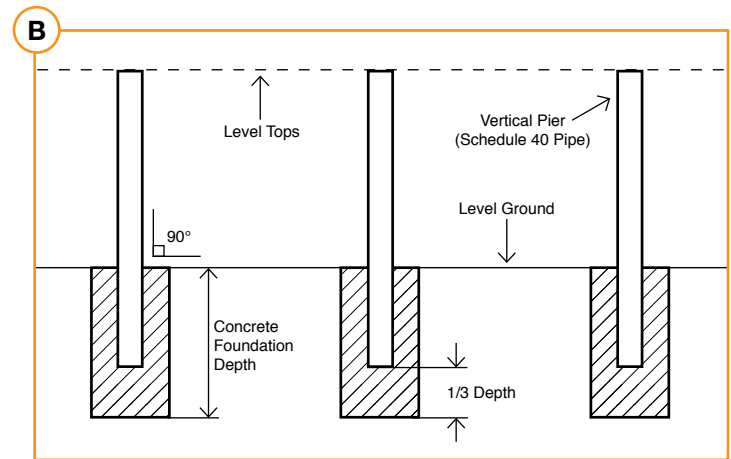
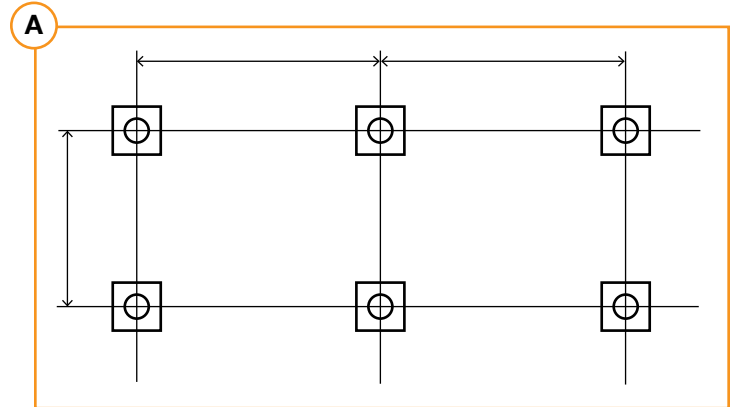

2. CONNECT SUBSTRUCTURE

A. MOUNT TOP CAPS

Mount a Top Cap on each pier. Wait to tighten set screws.

- ☑ If using [Diagonal Braces](#), install them prior to Top Caps.

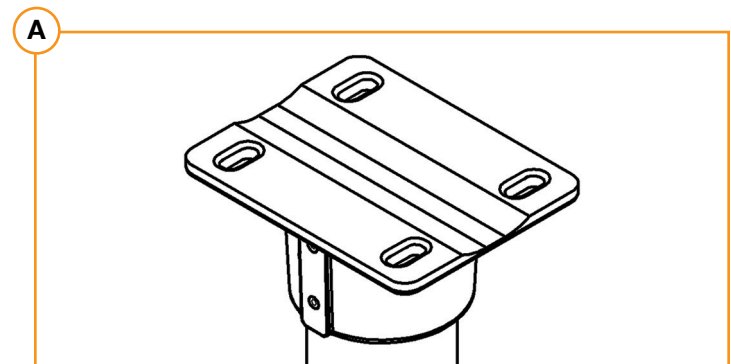

B. LAY CROSS PIPE

Set cross pipes/tubing in Top Cap grooves. Attach with 3/8"-16 U-bolts, flange nuts, flat washers, and lock washers. Torque U-bolts to 180 in-lbs. Complete and align entire assembly. Torque Top Cap set screws to **240 in-lbs** for Schedule 40 Pipe, **132 in-lbs** for 2" Allied Mechanical Tubing, and **192 in-lbs** for 3" Allied Mechanical Tubing.

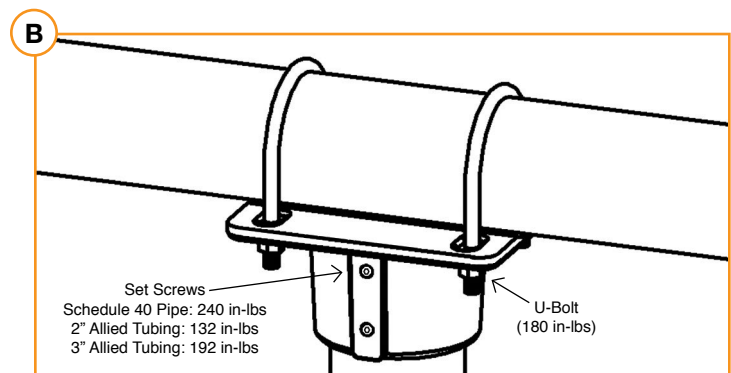

3. PLACE RAILS

A. ATTACH HARDWARE

On ground, attach Rail Connector bracket to rail by sliding 3/8"-16 bolts into side slot. Space out to match pier spacing. With bracket in place, finger tighten flange nuts onto bolts. Repeat for remaining Rail Connectors.

- ☑ If using Mid Clamps with hex bolts, slide provided 1/4"-20 bolts into top slot of rails at this time. Space bolts for panel spacing.
- ☑ Tape ends of rail, to keep bolts from sliding out while moving.

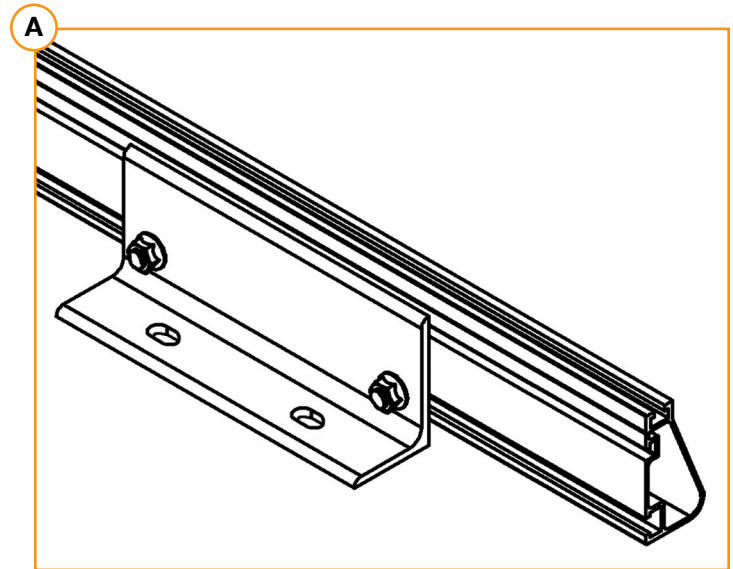

B. FASTEN CONNECTORS

Center rails on cross pipes, leaving equal distance on ends. Secure with Rail Connector hardware: 3/8"-16 U-bolts, flange nuts, flat washers, and lock washers. Torque U-bolt to **60 in-lbs** and bracket to **204 in-lbs**.

- ☑ Spacing between rails should align with module mounting holes.

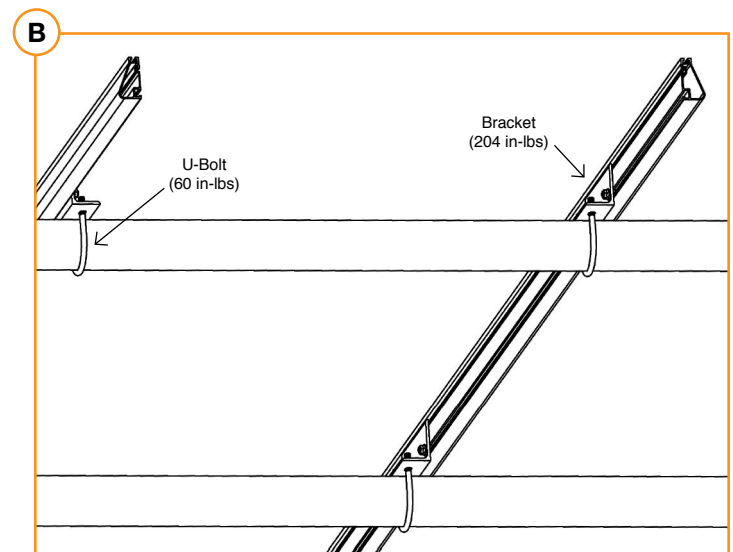

4. SECURE LUGS

WEEB LUGS

Review Wiley [WEEB Installation Instructions](#), using 6-10 AWG (minimum) solid copper grounding wire. Torque hex nut to **120 in-lbs** and set screw to **84 in-lbs**.

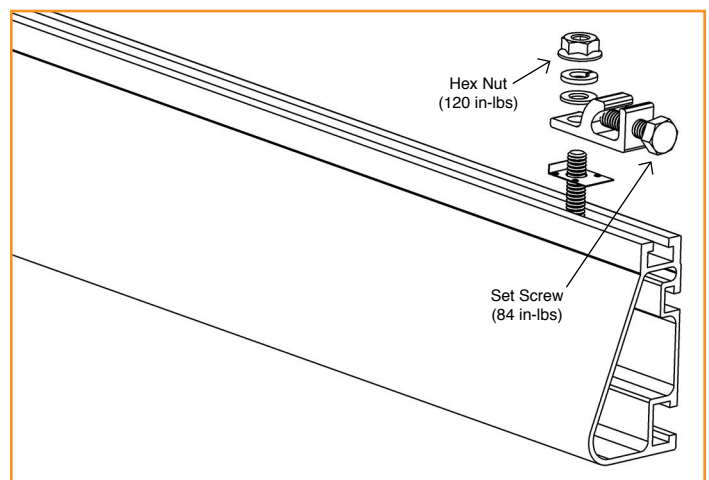

5. CLAMP MODULES

A. END CLAMPS

Place first module in position on rails, a minimum of 1.5" from rail ends. Secure End Clamps on rails, ensuring they are hooked over top of module. Torque to **84 in-lbs**.

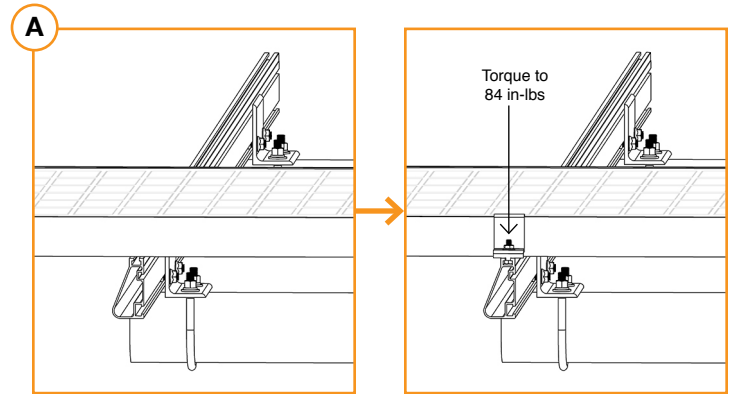

B. MID CLAMPS

Slide Mid Clamp T-bolts in top rail slots, placing them flush against opposite side of module. Place second module into position on rails, against Mid Clamp bolts. Put a Mid Clamp, then flange nut, on each bolt. Torque to **120 in-lbs**. Repeat for each following module.

- ☑ Refer to [WEEB Installation Manual](#) for installing WEEB Clips.
- ☑ If using Under Clamps or Wire Clips, refer to [Page 6](#).
- ☑ If using Grounding Mid Clamps, refer to [Grounding Mid Clamp Installation Manual](#).

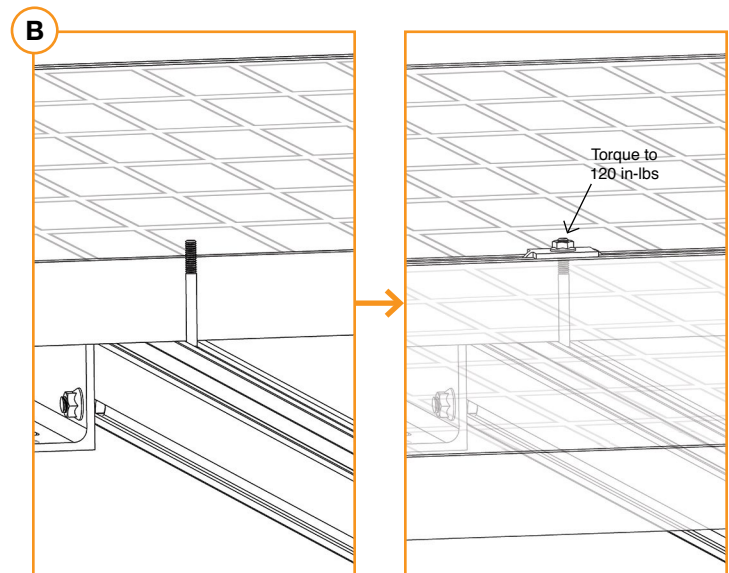

C. END CLAMPS

Place last module in position on the rails, a minimum of 1.5" from rail ends. Secure End Clamps on rails, ensuring they are hooked over top of module. Torque to **84 in-lbs**.

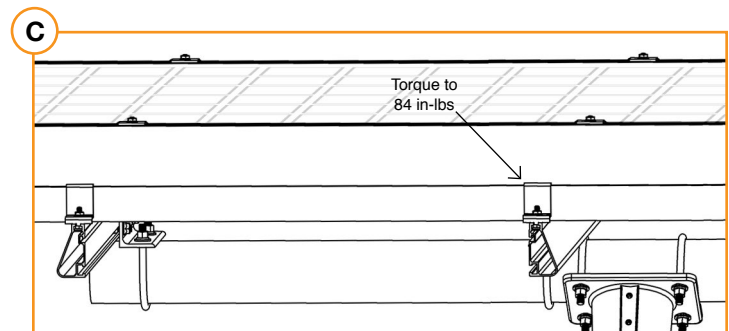

D. REPEAT STEPS

Clamp remaining module rows:

- ☑ If using End Caps, refer to [Page 6](#).

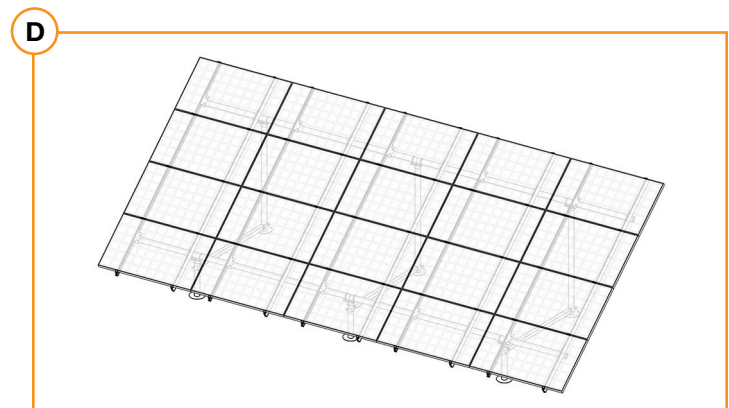

DIAGONAL BRACES (OPTIONAL)

Slide sleeve on north pier, 2-3" above the ground. Attach Diagonal Brace to sleeve with 1/2" hardware. Slide second sleeve on south pier, raising Diagonal Brace to align holes in sleeve and brace. Attach hardware and raise sleeve to full extent. Torque Diagonal Brace assembly to **480 in-lbs**.

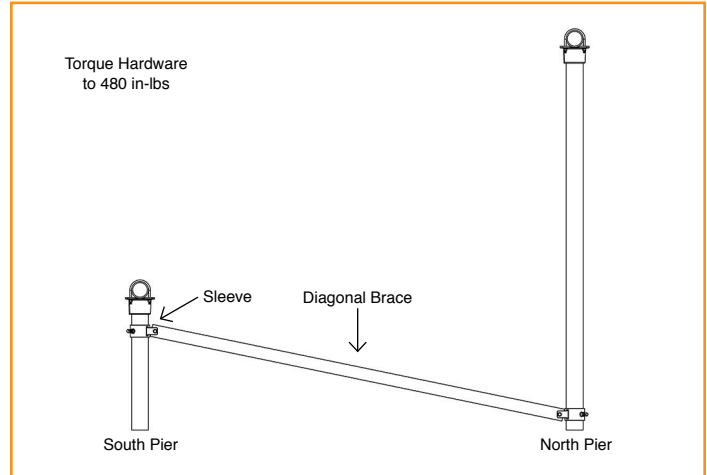

UNDER CLAMPS (OPTIONAL)

Slide Under Clamp into side rail slot. Line up Under Clamp with module mounting holes and attach with hardware. Torque hardware to **120 in-lbs**.

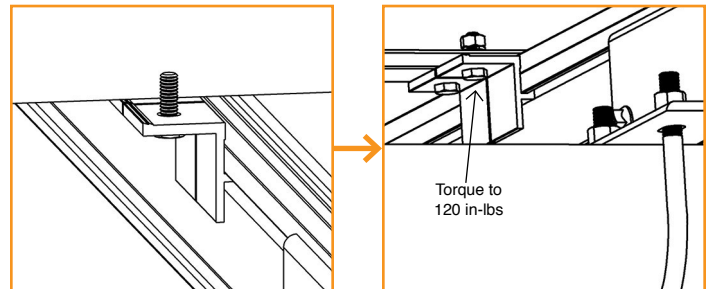

END CAPS (OPTIONAL)

End Caps add a completed look and keep debris and pests from collecting inside rail.

Firmly press End Cap onto rail end.

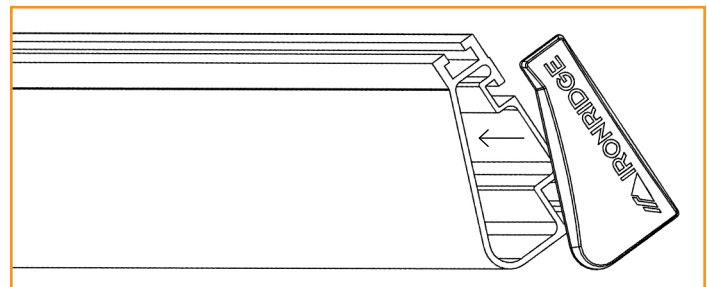

WIRE CLIPS (OPTIONAL)

Wire Clips offer a simple wire management solution.

Firmly press Wire Clip into top rail slot. Open clip and insert electrical wire accordingly. Close clip once complete.

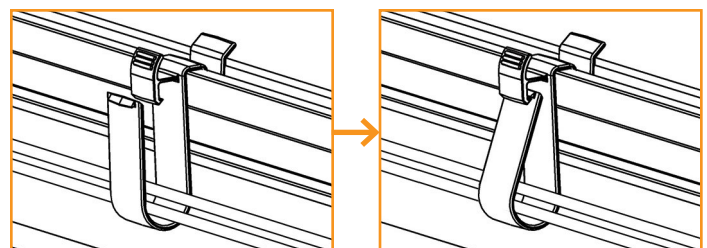

WARRANTY

Effective for Products manufactured after April 1st, 2012, IronRidge provides the following warranties, for Products installed properly and used for the purpose for which the Products are designed:

(a) Products with finishes (ie excluding without limitation Products that are mill finished) shall be free of visible defects, peeling, or cracking, under normal atmospheric conditions, for a period of three years from the earlier of (i) the date of complete installation of the Product or (ii) 30 days after the original purchaser's date of purchase of the Product ("Finish Warranty"); (b) components shall be free of structurally-related defects in materials for a period of ten years from the earlier of (i) the date of complete installation of the Product or (ii) 30 days after the original purchaser's date of purchase of the Product; and (c) components shall be free of functionally-related manufacturing defects for a period of 20 years from date of manufacture.

The Finish Warranty does not apply to: (d) surface oxidation of the galvanized steel components or any foreign residue deposited on Product finish; and (e) Products installed in corrosive atmospheric conditions, as defined solely by IronRidge; corrosive atmospheric conditions include, but are not limited to, conditions where Product is exposed to corrosive chemicals, fumes, cement dust, salt water marine environments or to continual spraying of either salt or fresh water.

The Finish Warranty is VOID if (f) the practices specified by AAMA 609 & 610-02 – "Cleaning and Maintenance for Architecturally Finished Aluminum" (www.aamanet.org) are not followed by Purchaser for IronRidge's aluminum based components; and (g) if the practices specified by ASTM A780 / A780M - 09 "Standard Practice for Repair of Damaged and Uncoated Areas of Hot-Dip Galvanized Coatings" are not followed by Purchaser for IronRidge's galvanized steel-based components.

The warranties above do not cover any parts or materials not manufactured by IronRidge, and exclude non-functionally-related defects, as defined solely by IronRidge. The warranties do not cover any defect that has not been reported to IronRidge in writing within 20 days after discovery of such defect.

In the event of breach of or non-compliance with the warranties set forth above, IronRidge's sole obligation and liability, and the sole and exclusive remedy for such breach or non-compliance, shall be correction of defects by repair, replacement, or credit, at IronRidge's sole discretion. Such repair, replacement or credit shall completely satisfy and discharge all of IronRidge's liability with respect to these warranties.

Refurbished Product may be used to repair or replace the defective components. Transportation, installation, labor, or any other costs associated with Product replacement are not covered by these warranties and are not reimbursable. These warranties additionally do not cover (h) normal wear, or damage resulting from misuse, overloading, abuse, improper installation (including failure to follow professional instruction and certification), negligence, or accident, or from force majeure acts including any natural disasters, war or criminal acts; and (i) Products that have been altered, modified or repaired without written authorization from IronRidge or its authorized representative; and (j) Products used in a manner or for a purpose other than that specified by IronRidge. A formal document proving the purchase and the purchase date of the Product is required with any warranty claim.

Except as set forth above, IronRidge sells the Products on an "AS IS" basis, which may not be free of errors or defects, and ALL EXPRESS OR IMPLIED REPRESENTATIONS AND WARRANTIES, INCLUDING ANY WARRANTIES OF MERCHANTABILITY, FITNESS FOR A PARTICULAR PURPOSE, QUALITY, WORKMANLIKE EFFORT, CORRESPONDENCE TO DESCRIPTION, DESIGN, TITLE OR NON-INFRINGEMENT, OR ARISING FROM COURSE OF DEALING, COURSE OF PERFORMANCE OR TRADE PRACTICE, ARE HEREBY DISCLAIMED.