

PV Rapid Shutdown device

Installation and Operation Manual

Solis-RSD1L-1G

Solis-RSD2L-1G



Manufacturer: Ginlong (Ningbo) Technologies Co.,Ltd., Ningbo, Zhejiang, P.R.China

US Office: 565 Metro Pl. S. Suite 3214, Dublin OH 43017, USA

Toll-free: 866.438.8408 | Email: sales@ginlong.com | sales@ginlong-usa.com

Web: www.ginlong.com | www.ginlong-usa.com

Please record the serial number of your Rapid Shutdown Device and quote this when you contact us.

© 2016, Ningbo Ginlong Technologies Co., Ltd.

Contents

1. Introduction	2
1.1 Product Description	2
1.2 Packaging	3
2. Safety Instructions	4
2.1 Safety Symbols	4
2.2 General Safety Instructions	4
3. Installation	6
3.1 System diagram	6
3.2 Installation	7
4. Commissioning	12
5. Troubleshooting	12
6. Specifications	13
6.1 Technical Specifications	13

1. Introduction

1.1 Product Description

The Solis Rapid Shutdown Devices (RSD) are certified to the UL 1741 inverter standard and comply to all 2014 National Electrical Code 690.12 Rapid Shutdown requirements. Solis RSD's are packaged inside NEMA 4X enclosures that fit neatly under the modules. The RSD is controlled by an AC signal circuit. A green LED on the RSD indicates that AC power is supplied to the RSD and that RSD PV output circuits may be energized. When first responders cut AC power to the building, the RSD(s) will force the PV array and DC capacitors inside the inverter(s) to drop to less than 30VDC and less than 240VA in less than 10 seconds.



▲ Figure 1.1 Front side view



▲ Figure 1.2 Back side view

1. Introduction

1.2 Packaging

When you receive the RSD, please ensure that all the parts listed below are included:

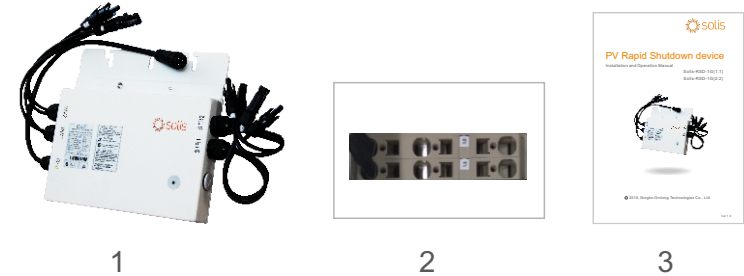

▲ Figure 1.3 Parts

Part #	Description	Number
1	Rapid Shutdown Device	1
2	AC Terminal Assembly	2
3	Manual	1

▲ Table 1.1 Parts list

2.Safety Instructions

Improper use may result in potential electric shock hazards or burns. This manual contains important instructions that must be followed during installation and maintenance. Please read these instructions carefully before use and keep them for future reference.

2.1 Safety Symbols

Safety symbols used in this manual, which highlight potential safety risks and important safety information, are listed as follows:



WARNING:

WARNING symbol indicates important safety instructions, which if not correctly followed, could result in serious injury or death.



CAUTION:

CAUTION, RISK OF ELECTRIC SHOCK symbol indicates important safety instructions, which if not correctly followed, could result in electric shock.



CAUTION:

CAUTION, HOT SURFACE symbol indicates safety instructions, which if not correctly followed, could result in burns.

2.2 General Safety Instructions



WARNING:

Incorrect operation or maintenance can cause serious injury and damage to property. Only qualified personnel to commission the Rapid Shutdown Device and only within the scope of the respective technical regulations. Read the safety rules before commissioning and performing maintenance work.



WARNING:

Work performed incorrectly can cause serious injury and damage. The Rapid Shutdown Device should only be installed by qualified personnel. Follow the safety rules!
Before any installation or connection work is carried out, disconnect the AC supply to the inverter and the DC supply to the Rapid Shutdown Box.

2.Safety Instructions



CAUTION:

An electric shock can be fatal. Inadequately sized electrical components can cause serious injury and damage to property.
- All electrical connections must be made in accordance with the National Electrical Code, ANSI/NFPA 70, and any other regulations applicable to the installation site.
- Use min. 194°F (90°C) copper wire for all grounding wires (see NEC table 250.122).
- Voltage drop and other considerations may mean larger cable cross sections need to be used. The PV array (i.e. the solar panel") supplies a DC voltage when it is exposed to sunlight.



ATTENTION:

ATTENTION; Installers of the RSD shall have a reflective, white-on-red, permanent plaque or directory that includes the following wording;
PHOTOVOLTAIC SYSTEM EQUIPPED WITH RAPID SHUTDOWN



CAUTION:

The surface temperature of the RSD can reach up to 75C (167F). To avoid risk of burns, do not touch the surface of the RSD when it is operating.

3. Installation

3. Installation

3.1 System Diagram

The Ginlong Rapid Shutdown Device is controlled by an AC signal circuit. If AC power is cut at the utility service entrance and/or at the inverter AC output circuit disconnect, the RSD will be activated and the PV array will drop to less than 30 volts in less than 10 seconds (per 2014 NEC 690.12).

Solis-RSD1L-1G

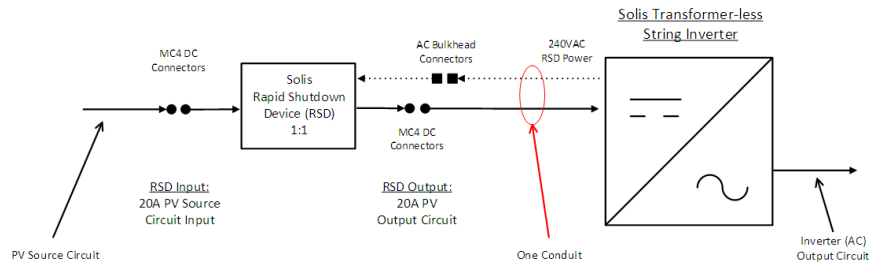

Solis-RSD2L-1G

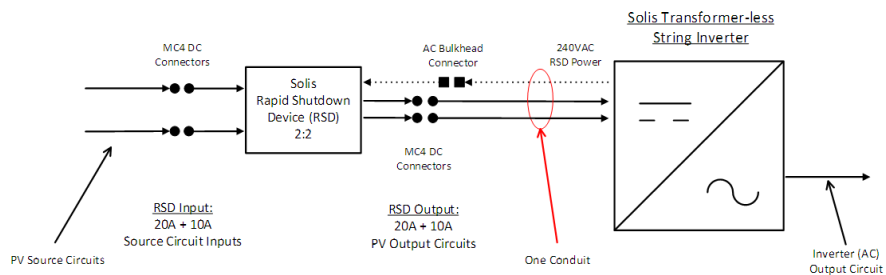

▲ Figure 3.1 System diagram

3.2 Installation

RSD is designed to mount on the rack under PV modules.
Step 1. Attaching RSD to the racking.

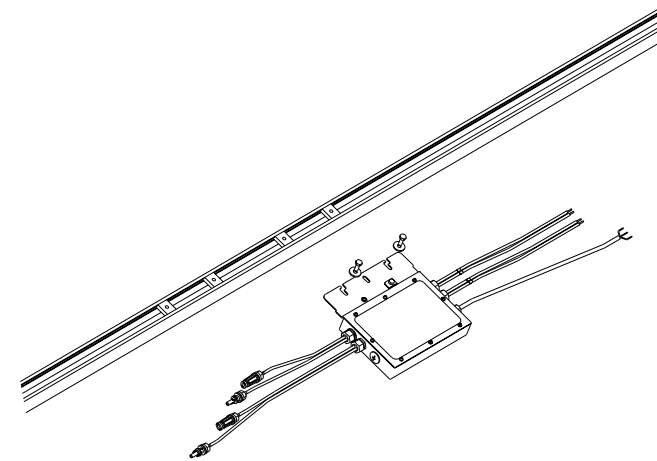

▲ Figure 3.2 Attaching RSD to rack

- a. Evaluate the location of the RSD with respect to the PV module junction box or any other obstructions.



WARNING:

Allow a minimum of 3/4 inches between the top of the roof and the bottom of the RSD. We also recommend that you allow 1/2 inches between the back of the PV module and the top of the RSD. Do not mount the RSD in a location that allows exposure to direct sunlight.

- b. If using grounding washers (e.g. WEEB) to ground the RSD chassis to the PV module racking, choose a grounding washer that is approved for the racking manufacturer. Install a minimum of one grounding washer for RSD. The Torque for the fasteners values listed below:

- 1/4" mounting hardware – 45 inlbs minimum
- 5/16" mounting hardware – 80 inlbs minimum.

3. Installation

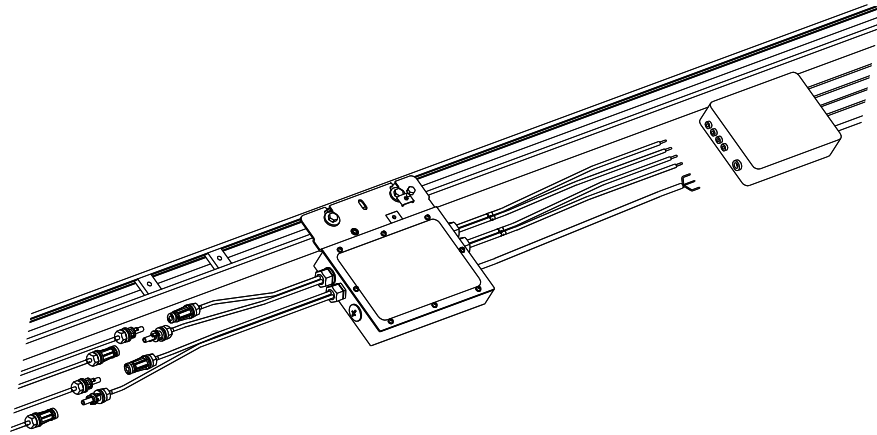

▲ Figure 3.3 Fix the screws

Step 2 - Using MC4 connectors, connect the DC input and DC output wires.

RSD-1G(1:1) DC connection:

The single channel Solis-RSD1L-1G is rated for 20 amps. Installers may parallel wire 2 pair of PV string conductor to the input connectors.

However, the total I_{max} current must be less than 20 amps and I_{sc} current less than 31.2 amps. Any parallel wiring of PV module strings on the roof must be accomplished per NEC guidelines.

RSD-1G(2:2) DC connection:

The dual channel Solis-RSD2L-1G is rated for 30 amps. Either channel can accept 20 amps (31.2 I_{sc}). Installers may parallel wire 2 pair of PV string conductors to one of the channels on the RSD2L.

However, when the installer connects a PV string(s) to the second channel, they must be sure that the 30 amp total RSD2L enclosure rating has not been exceeded. Any parallel wiring of PV module strings on the roof must be accomplished per NEC guidelines.

3. Installation

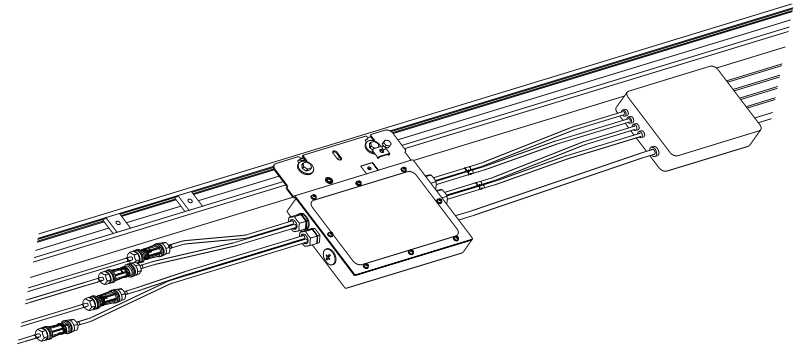

▲ Figure 3.4 Connect DC input connectors

a. Connect PV strings to RSD "STR DC" side, connect inverter DC input and RSD AC input to the wiring box.



WARNING:

The string input PV+ and PV- must match RSD PV+ and PV-. Reverse PV input polarity could damage the RSD and void the warranty.

Step 3 - Grounding the System

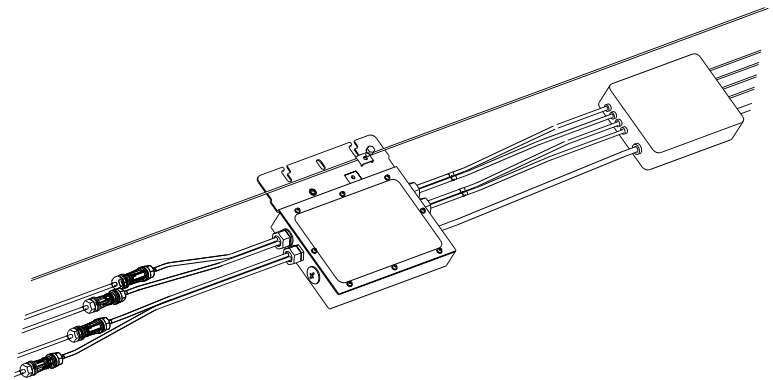

▲ Figure 3.6 Ground connection

3. Installation

If you are not using grounding washers to ground the RSD chassis please follow the step below. Each RSD comes with a ground clip that can accommodate a single #6, #8, or #10 AWG conductor. Check your local code for grounding conductor sizing requirements.

a. Connect the grounding electrode conductor to the RSD ground clamp. Torque the RSD ground clamp to 20 in-lbs, 2.25 N-m. The racking and module could be grounded to this conductor using a crimp connection.

Step 5 – Complete the RSD installation by routing the RSD DC output conductors and the AC signal circuit conductors to the wire box on the Solis inverter.

a. Follow instructions in the Ginlong Inverter Installation Manual to connect the RSD DC output conductors to the inverter DC input terminal blocks inside the inverter wire box. Check to ensure that DC polarity is correct.

Step 4 - Connect RSD DC output and AC to the inverter

a. Follow instructions in the Ginlong Inverter Installation Manual to connect the RSD DC output conductors to the inverter DC input terminal blocks inside the inverter wire box. Check to ensure that DC polarity is correct.

b. Connect RSD “GRID”

Connect the RSD “GRID” conductors (i.e. AC signal circuit conductors) to a 240VAC termination point, inside or outside the Ginlong Solis inverter wire box.

A 2-amp ac fuse is integrated in RSD to protect the RSD AC signal circuit components and conductors.

Due to some of Solis 2G inverter is not designed to match RSD, so there are two pin terminal in RSD accessory, installer may need to replace the L1 and L2 terminal of the inverter to the 2 pin connector.

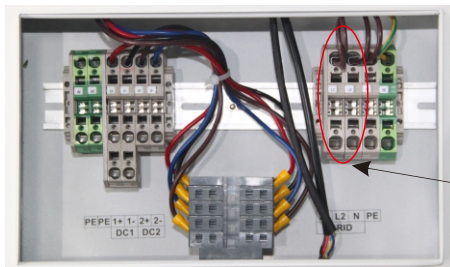

Raise the root side of the L1 and L2 terminal

Raise the root side of the L1 and L2 terminal to replace the L1 and L2 terminal

3. Installation

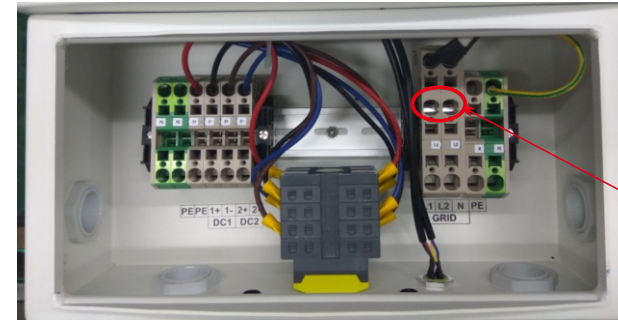

RSD grid connection



Attention

To ensure AC signal quality, the AC signal circuit conductors must be no longer than 100 meters.



Attention

After installation of one or more RSD's on site, the system installer will install a plaque (per 2014 NEC 690.56(C)) that reads:

PHOTOVOLTAIC SYSTEM EQUIPPED WITH RAPID SHUTDOWN.

Additional signage on site can include a plaque next to the Inverter AC Disconnect Switch that reads:

OPERATION OF THE PV SYSTEM AC DISCONNECT SWITCH WILL RESULT IN RAPID SHUTDOWN OF THE PHOTOVOLTAIC ARRAY AND INTERRUPTION OF SYSTEM POWER.



WARNING:

The RSD and all ac connections to the utility grid must only be made by qualified personnel.



WARNING:

Ensure that all AC and DC wiring is correct. Ensure that none of the AC and DC wires are pinched or damaged. Ensure that all wiring boxes are properly closed.

4. Commissioning

To commission the PV system with the Solis RSD(s) installed:

- a. Move the Inverter AC output circuit disconnect switch to the ON position
- b. Move the PV system inverter output circuit breakers to the ON position
- c. Ensure that RSD AC signal circuit conductors are energized
- d. Confirm the correct polarity of the DC input circuit conductors.
- e. Move the DC switch on the inverter to the ON position
- f. Confirm the inverter turns ON in 300 seconds (5 minutes)

5. Troubleshooting



WARNING:

The RSD and all ac connections to the utility grid must only be made by qualified personnel.

Failure of the RSD could interrupt DC power to the inverter. If the installer checks the DC input terminals at the inverter and does not detect PV voltage, the installer should follow the procedure below:

- a. Check DC string voltage at the inverter as a way to isolate the issue to the RSD or to the inverter.
- b. If the DC voltage can be measured at the DC input terminals at the inverter, follow inverter troubleshooting instructions.
- c. If DC voltage cannot be measured at the DC input terminals at the inverter, Check the AC signal circuit connection point to confirm that AC power is available at these terminals.
- d. If there is AC power at the AC signal circuit connection point, check to see if the RSD LED is lit. This would indicate that the RSD has AC signal circuit power. Check for loose MC4 connections at the RSD DC inputs and outputs.
- e. If the RSD LED is off, check all AC and DC cable connections.
- f. After confirming the integrity of the DC cable connections and confirming that the RSD is receiving AC power, but the LED is still OFF, replace the RSD.

6. Specifications

6.1 Technical Specifications

DC	Solis-RSD1L-1G
Maximum Input and Output Voltage	600VDC
DC Input Voltage Range	30-600VDC
Maximum Number of PV Source Circuits	1 input / 1 output
Maximum Input / Output Current	20A
Maximum Short Circuit Current	31.2A
DC Input / Output Cable Whips	PV Wire with MC4 Locking Connectors
DC Input / Output Wire Size	AWG #12 to #6
Ground Wire Size	AWG #10 to #6
AC	
Rated AC Input Voltage	208/240VAC
Rated AC Input Current	0.1A
Rated Frequency	50/60Hz
AC Control Wire Size	AWG #18 to #14
Maximum AC Fuse Rating	2A
GENERAL	
Ambient Temperature Range	-25 to +65°C (-13 to 158°F)
Enclosure Type	NEMA 4X
Roof Mount Style	Rail-mount plate (WEEB Compatible)
Status Indicator	LED
Efficiency	>99.5%
Response Time	<2 seconds
Dimensions (W*H*D)	262*240*43 cm / 10.3*9.4*1.7 in
Weight	2.3 kg / 5.1 lb
Warranty	10 Year
Certification & Safety Standard Compliance	UL1741, FCC Part 15 Class B, NEC 690.12

6. Specifications

DC	Solis-RSD2L-1G
Maximum Input and Output Voltage	600VDC
DC Input Voltage Range	30-600VDC
Maximum Number of PV Source Circuits	2 input / 2 output
Maximum Input / Output Current	10/20A
Maximum Short Circuit Current	31.2A
DC Input / Output Cable Whips	PV Wire with MC4 Locking Connectors
DC Input / Output Wire Size	AWG #12 to #6
Ground Wire Size	AWG #10 to #6
AC	
Rated AC Input Voltage	208/240VAC
Rated AC Input Current	0.1A
Rated Frequency	50/60Hz
AC Control Wire Size	AWG #18 to #14
Maximum AC Fuse Rating	2A
GENERAL	
Ambient Temperature Range	-25 to +65°C (-13 to 158°F)
Enclosure Type	NEMA 4X
Roof Mount Style	Rail-mount plate (WEEB Compatible)
Status Indicator	LED
Efficiency	>99.5%
Response Time	<2 seconds
Dimensions (W*H*D)	262*240*43 cm / 10.3*9.4*1.7 in
Weight	2.4 kg / 5.2 lb
Warranty	10 Year
Certification & Safety Standard Compliance	UL1741, FCC Part 15 Class B, NEC 690.12