



Installation Guide

90033-000



DuraTrack™ DA

DUAL AXIS AZIMUTH DRIVE TRACKER

Array Technologies, Inc.

3901 Midway Place NE
Albuquerque, NM 87109
USA

January 2014

Rev A-01

Copyright © 2014 Array Technologies, Inc. All Rights Reserved

Table of Contents

1	Welcome	1
1.1	How This Manual is Organized	1
1.2	Alert Messages.....	3
1.3	Hazard Symbols	4
1.4	We Invite Your Comments	5
2	System Description	6
2.1	Structural and Mechanical Features	7
3	Safety	8
3.1	Protective Gear	8
3.2	Recommended Safety Procedures	8
3.2.1	Ladder Safety.....	8
3.3	Lockout and Tagout	10
3.3.1	Lockout and Tagout Devices	10
3.4	Hazards	10
3.4.1	High Voltage	10
4	Site Evaluation	11
4.1	Topography	11
4.2	Soil Conditions	11
4.3	Elemental Requirements	11
4.4	System Size	11
4.4.1	Electrical and Mechanical Requirements.....	11
4.4.2	Field Layout	11
5	Assembly Drawings.....	12
6	Site Preparation	12
6.1	Permits and Studies	12
6.2	Grading.....	12
6.3	Security	12
7	Material Handling.....	13
7.1	Transportation	13
7.2	Receiving Materials.....	13
7.3	Lifting and Moving	14
7.4	Storage.....	14
7.5	Additional Tools and Materials Required	15
7.6	Spare Parts	15
7.7	Disassembly.....	15
8	Tracker Foundation and Support Column.....	16
8.1	Support Column	16
8.2	Foundation Installation	16
8.2.1	Vibratory or Hammer Driven Piles	16
8.2.2	Concrete Foundation	17
8.2.3	Alternate Foundations.....	17

8.2.4	Pile Tolerances	17
8.2.5	Support Column	17
8.3	General Assembly Instructions	18
8.3.1	Torque Procedure	18
8.3.2	System Components.....	19
9	Install DuraTrack™ DA Tracker Foundation and Support Column	23
9.1.1	Concrete Foundation Support Column Installation.....	23
9.1.2	Installation of equipment on the Support Column.....	24
10	Install Motorized Drive and Actuator	25
10.1	Install Motorized Drive.....	26
10.2	Install Actuator.....	31
11	Install Torque Tube and Module Support Frame Structure.....	32
11.1	Install Torque Tube	32
11.2	Install Module Support Frame Racking.....	34
11.2.1	Support Rack Installation.....	35
12	Attach Modules	38
12.1	Module Installation	38
12.2	Grounding Suggestions.....	40
13	Install Dual Axis Tracker Controller Components	42
13.1	Controller Function, Features and Specifications	42
13.1.1	ATI Controller Function	42
13.1.2	ATI Controller Standard Features.....	42
13.1.3	ATI Controller Specifications	43
13.2	Controller Connection Ports	44
13.3	Install the Remote Sensor	45
13.3.1	Remote Sensor mechanical installation.....	45
13.3.2	Remote Sensor electrical connection	46
14	Power Connection to the Tracker Components.....	47
14.1	Power Connection to the Elevation Actuator	47
14.1.1	DC input polarity during normal operation	47
14.2	Power Connection to the Tracker Controller.....	50
14.2.1	Powering the ATI Controller from a constant power source.....	51
14.2.2	Battery Bank to Controller Circuit simplified wiring diagram:.....	52
14.2.3	Controller Diagram:.....	52
15	Tracker Preferences and Operation	53
15.1	Manual Control.....	53
15.1.1	Manual Control Function:.....	53
15.1.2	Manual Control Switch Operation:	53
15.1.3	High Wind Locations	54
15.1.4	Heavy Snow Locations	54
15.2	Tracker Controller Operation and Dip Switch Options	55
15.2.1	Survey the work area:	55
15.2.2	Remove the controller cover:	56

15.2.3	Perform Tracker Controller Test	57
15.2.4	Setting the Sensor Light Sensitivity:	58
15.2.5	Interior Fuse	58
15.3	Motor Limits	60
16	Recommended Grounding Instructions	61
16.1	Grounding Modules, Tracker Frame, Drive and Mounting Pipe	62
16.2	Ground Tracker to the Battery Bank/Power Center	63
16.3	Alternate Grounding for Tracker Remote from Battery Bank/Power Center	64
Appendix A	Additional Tools and Materials Required	A-1
Appendix B	Warranty Terms.....	B-1
Appendix C	Recommended Maintenance	C-1
Appendix D	Troubleshooting.....	D-1
Appendix E	Revision History.....	E-1
Index	I

1 Welcome

This document describes the correct installation of Array Technologies, Inc. DuraTrack™ DA Dual Axis Tracker; it is confidential and proprietary and subject to all controls as described in our Mutual Non-Disclosure Agreement (MNDA), if applicable. As such, this document and/or its contents, in whole or in part, cannot be disseminated, distributed, provided to, or discussed with anyone without a need to know this information and without an executed MNDA with Array Technologies, Inc. Any use of this document for any purpose other than its intended use as an installation guide is prohibited unless prior written permission is obtained from ATI.

1.1 How This Manual is Organized

This guide is provided to enable the correct and efficient installation of the Array Technologies, Inc. (ATI) DuraTrack™ DA Dual Axis Tracker. ATI recommends that you study the entire guide and understand all elements prior to beginning installation and reference the step-by-step procedures as needed throughout the installation. The following is a brief overview of the chapters.

Chapter 2, System Description

A basic description of a sample DuraTrack™ DA is presented.

Chapter 3, Safety

Protective gear, recommended safety procedures, and potential hazards are discussed.

Chapter 4, Site Evaluation

Topography, soil conditions, elemental requirements, and system size recommendations are presented.

Chapter 5, Assembly Drawings

A high-level summary of the ADP is discussed. The ADP is a product-specific, customized document separate from this installation guide.

Chapter 6, Site Preparation

Permits and studies, grading, and security are discussed.

Chapter 7, Material Handling

Transportation, receiving materials, lifting and moving, storage and checklists for major component equipment are listed.

Chapter 8, Tracker Foundation and Support Column

ATI tracker foundation design and installation and general assembly instructions are presented.

Chapter 9, Install DuraTrack™ DA Tracker Foundation and Support Column

Installing the foundation and support column for the tracker is described.

Chapter 10, Attach Modules

Installing the motorized drive and elevation actuator is presented.

Chapter 11, Install Torque Tube and Module Racking

Installation of the module support structure is described.

Chapter 12, Attach Modules

Installing modules using the Array Technologies Universal Racking System and module grounding methods are presented.

Chapter 13, Install Dual Axis Tracker Controller Components

Controller function, features, specifications are discussed; elevation actuator and remote sensor installation is described.

Chapter 14, Power Connection to the Tracker Components

Power connection for the elevation actuator and tracker controller are described.

Chapter 15, Tracker Preferences and Operation

Controller operation, manual controls and motor limits are discussed.

Chapter 16, Recommended Grounding Instructions

Recommended grounding methods for the ATI tracker are described.

Appendix A, Additional Tools and Materials Required

Lists of recommended and optional tools and materials are included in this section.

Error! Reference source not found., **Overview Drawings and Bill of Materials**

Project overview drawings and project components list are presented.

0, Wiring Diagrams

Electrical component wiring diagrams are presented

Appendix D, Warranty Terms

The terms of the ATI Warranty are defined.

0, Recommended Maintenance

Standard maintenance and associated products are described.

Appendix D, Troubleshooting

Typical troubleshooting procedures are outlined.

Appendix D, Revision History

History of document revisions is recorded.

1.2 Alert Messages

Five levels of alert messages are used in ATI publications. The severity or importance of a message is indicated by the heading (Note, Tip, Caution, Warning, or Danger). These alert messages identify potential risks or unsafe practices and contain instructions for avoidance of hazards.



NOTE or TIP: A note or tip provides information about installation, operation, or maintenance of the system that is important to know, but is not necessarily hazardous. Tips are suggestions to make a process easier or more efficient.

Notes provide instruction or company policy for the protection of property, safe work practices, reminders of proper safety procedures, or the location of the safety equipment. The following is an example of a NOTE message:



NOTE

Do not torque any bracket hardware until entire row has been assembled. Bring hardware to “snug” only, allowing for necessary adjustment during row assembly.

CAUTION: A caution message alerts against behavior that can lead to personal injury or damage to property. The following is an example of a CAUTION message.



CAUTION

Only a certified welder should perform all welding in accordance with specifications provided in the installation Assembly Drawing Package.

WARNING: A warning message indicates a nearby hazard which, if not avoided, may result in serious injury or damage to property. The following is an example of a WARNING message.



WARNING

All bolts need to be torqued properly for the system to perform as specified. Not torquing the connections could result in system damage.

DANGER: A danger message indicates a hazard in the immediate area which, if not avoided, can result in death or serious injury. The following is an example of a DANGER message.



DANGER







Use proper lockout and tag out procedures before working on or around the module wiring. Contact with high voltage wiring could result in serious injury or death.

1.3 Hazard Symbols

This section explains the hazard symbols in Array Technologies, Inc. (ATI) documentation to identify information in the Caution, Warning, and Danger alerts.

These symbols comply with ANSI Z535 requirements.

Table 1-1 - Hazard Symbols

Symbol	Name and Description
	Arc Flash: Identifies potential arc flash and shock hazard that could result in injury or death. Appropriate personal protection equipment (PPE) and tools are required while working on energized equipment.
	Automatic Startup: Identifies equipment that is designed to start up automatically under certain conditions.
	Electrical Hazard. Identifies a potential electrical shock or burn hazard from electrical voltages.
	Entanglement Hazard (pinch point): Identifies mechanical parts that could strike or pinch while in motion.
	General Hazard. Identifies a set of recognizable conditions with the potential for initiating an event which could result in death, injury, or illness to people or damage to facility or equipment.
	Lockout/Tagout: Identifies possible exposure to hazards caused by failure to follow lockout/tagout procedures during this operation.
	Read Manual: Safety reminder to read and understand the operator's manual and safety instructions before using this equipment.

1.4 We Invite Your Comments

Array Technologies, Inc. (ATI) is a leading manufacturer of innovative, cost-effective, reliable, and robust solar systems. We invite your comments or feedback. Please provide general comments using the contact information below. For project-specific installation questions and/or concerns, please contact your designated ATI Sales Manager.

- URL: www.arraytechinc.com
- Email: residentialsales@arraytechinc.com
- Mailing address: 3901 Midway Place NE
Albuquerque, NM 87109 USA
- Phone: 505.881.7567
855.TRACKPV (872.2578)
- Fax: 505.881.7572

2 System Description

The Array Technologies Inc. DuraTrack™ DA Dual Axis Tracker is a 3.0 kW-4.0 kW residential-scale, azimuth gear driven, low maintenance photovoltaic (PV) continuous tracking system. The single pole-mount horizontal beam structure consists of 9-12 standard 60 cell PV modules mounted on a tracker rack support framework allowing tracking range from 5°-60° North/South and $\pm 120^\circ$ East/West.

The tracker is driven by a North/South linear actuator and East/West gear drive controlled by a closed loop optical sensor. The patented light-sensing technology provides standard tracking accuracy of $\pm 2^\circ$.

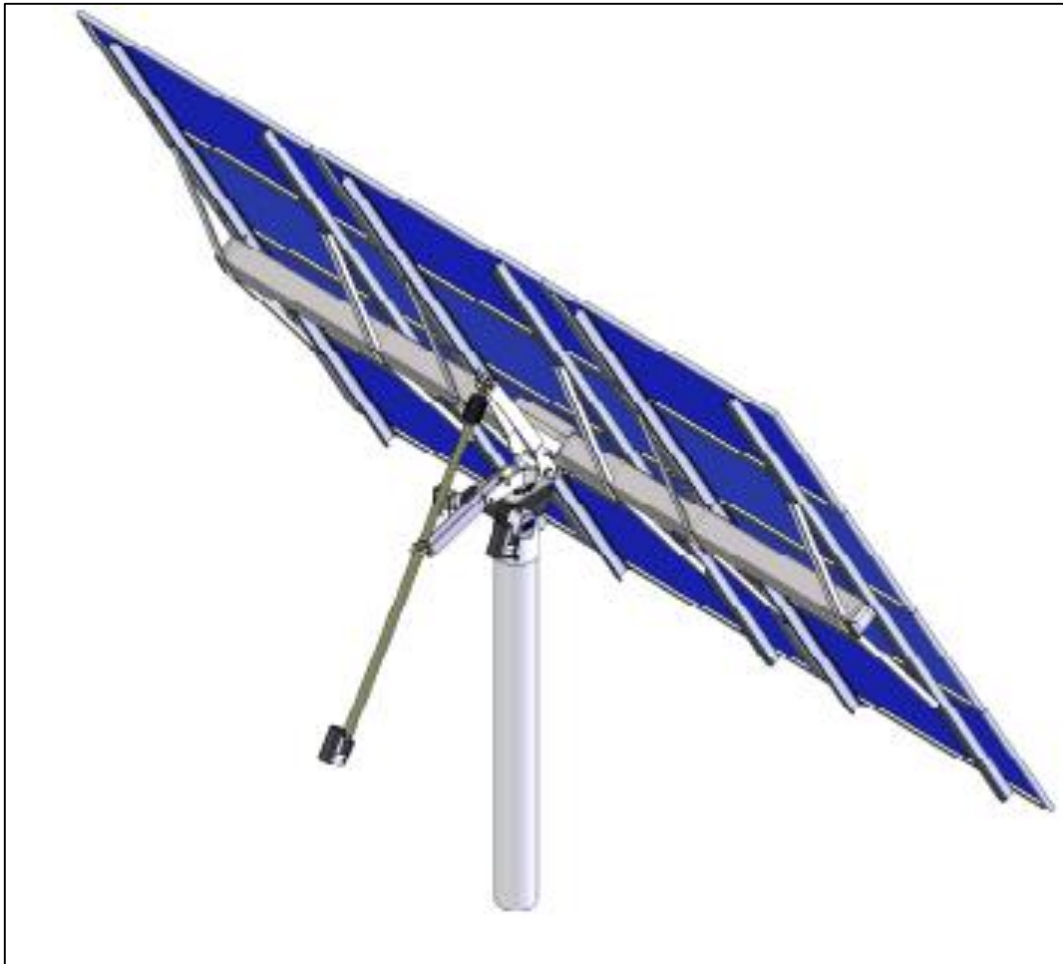

Sample Illustration of the DuraTrack™ DA Dual Axis Tracker

2.1 Structural and Mechanical Features

Table 2-1 shows structural and mechanical features and specifications for the DuraTrack™DA Dual Axis Tracker.

Table 2-1 - DuraTrack™DA Features

Feature	Specification
Racking/Tracking type	Dual Axis Tracker
Tracking range East – West	+/- 120°
Tracking range North – South	5° to 60°
East-West dimensions	21' max
North-South dimensions	14' max
Array height	15 ½' (pole height up to 8')
Allowable wind load	IBC 90 MPH, 3 – second gust exposure C
Modules supported	Most commercially available modules
Module configuration	12 single standard 60 cell modules in portrait
Module attachment	Proprietary extrusion with standard mounting bolts
Materials	Powder coated high-strength steel and anodized aluminum (Corrosion-resistant version optional)

3 Safety

This section contains important safety instructions for the ATI DuraTrack™ DA Tracker. These instructions must be followed during installation and maintenance procedures.



WARNING

Read and understand this installation guide and safety instructions before using the ATI DuraTrack™ DA Dual Axis tracker.

3.1 Protective Gear

Authorized service personnel shall wear the appropriate safety equipment as required by the local authority. ATI recommends the following personal protective equipment be worn when appropriate during installation, servicing, and maintenance of the solar array:

- Safety Hard Hat
- Safety Glasses
- Steel-toed Safety Boots
- Safety Vest
- Gloves or Hand Protection

3.2 Recommended Safety Procedures

ATI recommends using only certified professionals to perform the mechanical and electrical installation.

Thoroughly inspect all equipment, and verify that all tools and equipment are safely positioned and free from hazard prior to energizing.

3.2.1 Ladder Safety

- Read and follow all labels/markings on the ladder.
- Avoid electrical hazards! – Look for overhead power lines before handling a ladder. Avoid using a metal ladder near power lines or exposed energized electrical equipment.
- Always inspect the ladder prior to using it. If the ladder is damaged, it must be removed from service and tagged until repaired or discarded.
- Always maintain a 3-point (two hands and a foot, or two feet and a hand) contact on the ladder when climbing. Keep your body near the middle of the step and always face the ladder while climbing.
- Only use ladders and appropriate accessories (ladder levelers, jacks or hooks) for their designed purposes.
- Ladders must be free of any slippery material on the rungs, steps or feet.
- Do not use a self-supporting ladder (e.g., step ladder) as a single ladder or in a partially closed position.
- Do not use the top step/rung of a ladder as a step/rung unless it was designed for that purpose.
- Use a ladder only on a stable and level surface, unless it has been secured (top or bottom) to prevent displacement.
- Do not place a ladder on boxes, barrels or other unstable bases to obtain additional height.

- Do not move or shift a ladder while a person or equipment is on the ladder.
- An extension or straight ladder used to access an elevated surface must extend at least 3 feet above the point of support (see diagram). Do not stand on the three top rungs of a straight, single or extension ladder.
- The proper angle for setting up a ladder is to place its base a quarter of the working length of the ladder from the wall or other vertical surface (see diagram).
- A ladder placed in any location where it can be displaced by other work activities must be secured to prevent displacement or a barricade must be erected to keep traffic away from the ladder.
- Be sure that all locks on an extension ladder are properly engaged.
- Do not exceed the maximum load rating of a ladder. Be aware of the ladder's load rating and of the weight it is supporting, including the weight of any tools or equipment.

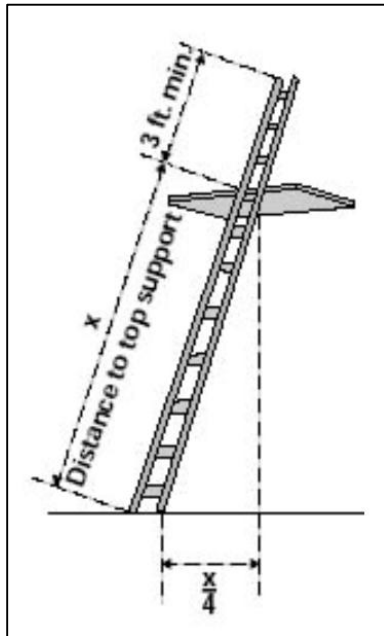

3.3 Lockout and Tagout

Ensure proper safety protocols and manufacturer recommendations are followed. Never work on an energized system.



NOTE

Lockout and Tagout procedures apply only to setup, service, or maintenance of the system, not to regular or normal operations.

3.3.1 Lockout and Tagout Devices

Lockout devices include padlocks, tags, chains, self-locking cable ties, hasps or other hardware. ATI recommends using Master lockout hasps or similar hasps. In addition to the lockout hasp, affix a tag indicating the date of lockout and name of the person who performed the lockout.



Figure 3-2 - Master Lockout Hasp Example



DANGER

Use proper lockout and tagout procedures before working on or around the module wiring. Contact with high voltage at the module wiring (600-1000VDC) could result in serious injury or death.

3.4 Hazards

A variety of hazards may be present during equipment installation, maintenance and operation. Improper handling or exposure to high voltage or entanglement hazards could cause serious injury and possibly death. Familiarize yourself with these hazards and always follow proper safety procedures.

3.4.1 High Voltage

A typical string of 10-20 modules can produce 600-1,000Vdc and can cause serious injury or death from improper contact or handling.



Figure 3-1 - High Voltage Warning Label

4 Site Evaluation

Each site is unique. Consideration of the topography, soil conditions, and elemental requirements determines the optimal site specific design. A certified Professional Engineer is recommended to evaluate and map the site topography, determine the soil conditions, and provide an opinion on any special environmental/elemental considerations.

4.1 Topography

System height, number of columns per row, and column size is impacted by the site topography. Evaluation of the topography may also determine the need for grading or other preparation of the land.

4.2 Soil Conditions

Soil conditions determine the size and installation requirements for the support columns. Depending upon soil type, vibratory driven piles, helical anchors, concrete pier foundation, or ballast may be required to install support columns.

4.3 Elemental Requirements

Elemental requirements are based on historical data of weather activity. The ultimate design of a system depends on reasonable estimates for snow load and wind speed requirements and other climate or weather conditions.

4.4 System Size

System size may be determined by any combination of the following factors: total electrical production, site solar resource, module characteristics, time of day/seasonal production requirements, potential shading and available space.

4.4.1 Electrical and Mechanical Requirements

Electrical requirements include system size, efficiency, string size, module, and inverter choices. Mechanical requirements include module attachment or orientation and electrical grounding.

4.4.2 Field Layout

The field layout is determined by the array density requirements, site boundary characteristics, and electrical design.

5 Assembly Drawings

Assembly Drawings are provided by Array Technologies.

The Assembly Drawings contain drawings and information with the following elements:

1. Product overview drawing
2. Column spacing for various configurations
3. Column specifications
4. Assembly Bill of Materials (BOM)
5. Torque tube assembly
6. Structural attachment details

All torques and installation instructions referred to within this manual are superseded by any drawing notes within the Assembly Drawings. If clarification is needed, contact ATI. ATI is not liable for incorrect installations.

6 Site Preparation

During Site Preparation, information obtained through site evaluation is used to prepare the site for installation. Preparation may include site grading, fencing, security, installation of environmental barriers, removal of obstacles, as well as the acquisition of permits.

6.1 Permits and Studies

A site may require permits or studies before any changes may be made to the landscape. If zoning restrictions apply, permits or waivers may be required. Refer to local zoning codes for all required permits and studies. A study may include consideration for archeological significance, endangered species, and visual or environmental impact. ATI is not responsible for the permitting process, but will provide support as needed.

6.2 Grading

Grading requirements are determined during the site evaluation and topography assessment (by others).

6.3 Security

ATI recommends establishing security controls for each site.

7 Material Handling

Handling materials properly is necessary to prevent damage to equipment and injury to personnel. ATI recommends the following requirements and considerations for proper materials handling.

7.1 Transportation

Materials may ship from multiple locations. ATI coordinates all logistics directly with the customer. Consult ATI to obtain accurate shipping information specific to your project.

7.2 Receiving Materials

Ensure the lay-down area for equipment delivery is adequate to accommodate the system components. All shipments must be inspected for damage prior to unloading. If there appears to be any damage, obtain photographs of the damaged material and provide to ATI within two (2) days for timely claim processing. In the event of missing pallets or tubing, please contact your ATI Sales Manager immediately.

Failure to report and document any damaged and/or missing components within two weeks of delivery will be accepted by ATI as recipient's verification that all material has been received in good condition and as stated on the shipment manifest.

ATI delivers shipments on flatbed or LTL Container trucks to ensure safe and efficient unloading at the site. All products shipping from our Albuquerque facility are bundled on standard pallets and can be removed using typical safe forklift procedures. The maximum weight of any single bundle is 500 pounds. Ensure on-site material handling equipment is certified for this maximum weight as well as appropriate for the site conditions.

ATI recommends the use of a site-appropriate forklift for the unloading and movement of materials. ATI recommends staging all material on level ground, at an appropriate distance from frequently-used passageways.

ATI recommends the following guidelines during unloading and staging of pallets and tubes:

- Adjust the forklift forks to their widest width prior to lifting the tubing.
- Balance and lift tubing from the center of the tubing.
- Use care to avoid damaging material with the forks during unloading and staging.
- Re-use the dunnage from the truck in the same spacing arrangement as was loaded on the truck (if applicable).
- Do not stack tubing higher than stacked during shipment.

The following items are recommended to unpack the received materials:

- Tin snips or wire cutter
- Box cutter or utility knife
- ½" wrench or hex-head ratchet
- Crowbar or claw hammer

7.3 Lifting and Moving

ATI recommends using the following guidelines for lifting and moving components to avoid potential injury to personnel or damage to equipment.

- ≤ 40 lbs (18 kg) one person
- ≥40 lbs but ≤100 lbs (45kg) minimum two people
- ≥100 lbs (45kg) use a forklift with a lifting hook or comparable mechanical lifting assistance.
- Oversized bundles, cartons or assemblies – minimum two people

7.4 Storage

Warehousing is recommended for spare parts or equipment. Structural components may be stored outdoors on pallets, mechanical components must be stored indoors and/or sheltered from weather. Never place components on unprotected ground or submerge in water. Components shipped in cardboard boxes should be kept dry if possible. **If cardboard boxes become damp, open the packages immediately to allow ventilation and drying.**

Although ATI's DuraTrack™ DA is designed to withstand outdoor environments, the installation process includes finishing and sealing of components subject to environmental degradation. Prior to installation, storage procedures must be followed to ensure system components are protected from damage due to weather, close quarter packing, and/or other location specific conditions.

1. None of ATI's equipment is rated for submersion in water or mud. Please ensure all staging areas are located above the normal construction flood plain level.
2. Much of ATI's equipment is packaged in cardboard boxes wrapped in plastic. These packages may be stacked and stored in similar orientations as loaded on the delivery truck.
3. Hardware can remain packaged as shipped until required for installation, unless the hardware cartons are wet in which case, they too must be opened and allowed to dry.
4. Do not stack tubing higher than stacked during shipment. Replicate the use and positioning of protective dunnage during shipping for storage (if applicable). Store tubing at a 3° slope to promote water shed during and after rain events. Verify the slope is uniform to ensure the entire length of pipe is in the same plane to prevent bowing.

Table 7-1 - DuraTrack™ DA Component Storage

Duration	Recommended
< 2 Weeks	<p>Store structural material outdoors as packaged and stacked upon arrival on site and following standard storage restrictions. Store mechanical and electrical components indoors or sheltered from weather if possible.</p> <p>If continuously exposed to moisture, store the steel tubing in a dry area/building, or unbundle the steel tubing to allow it to dry thoroughly after exposure to moisture (rain events and/or condensation).</p>
> 2 Weeks	Store material in a dry, indoor storage facility.

7.5 Additional Tools and Materials Required

Please refer to Appendix A for a list of additional tools, materials and equipment.

7.6 Spare Parts

ATI does not recommend spare parts above and beyond the few additional pieces which should accompany your shipment.

7.7 Disassembly

The ATI DuraTrack™ DA Dual Axis Tracker is designed for a long service life. In the event components or a system requires disassembly or removal, all ATI recommendations for material handling apply. Consult your local, regional, or national governance for disposal restrictions and requirements.

8 Tracker Foundation and Support Column



WARNING

High wind events can exert extreme forces on the tracker array, foundation and support column.

Prior to installing support columns, remove all obstacles from the site that may interfere with proper installation and/or operation of the DuraTrack™ DA tracker.

The support column supports all parts of the tracker. The height, type and location of columns is determined by the Foundation Designer.

Support columns must be installed plumb, and spaced according to the design drawings.

A surveyor marks the support column location in accordance with the Foundation Design. ATI recommends minimum 50' between columns for multiple-array sites.

8.1 Support Column

After the support column is located and marked, install the support column plumb and within the specified height differential. Maximum column heights from ground level are determined by the Foundation Designer.

Typically, the support column is specified as 1 x 8" ID SCH 80 Steel Pipe.



CAUTION

System foundation design and type are site specific. A Site Evaluation Report allows the foundation engineer to determine the appropriate foundation for your site. Install your system foundation only in accordance with your foundation engineer's specifications and the Assembly Drawings.

8.2 Foundation Installation

Support columns may be installed using a vibratory pile driver, a concrete foundation, helical piles or ballast. Refer to the Site Evaluation Report for allowable foundation types and minimum requirements provided by the foundation engineer.

8.2.1 Vibratory or Hammer Driven Piles

If soil conditions allow, and the project size is large enough to justify the mobilization of the necessary equipment, the use of driven piles is typically the most cost effective foundation option. Increased geotechnical sampling, foundation engineering and or verification testing may be required. Percussion hammers or vibratory pile machines are typically used for pile installation. The vibratory machine may have more capability than a hammer driver including the capability to remove piles if necessary. Using a pile driver, drive each column to the required height and depth.

8.2.2 Concrete Foundation

Caisson or spread concrete foundations may be specified when soil conditions or design criteria dictate their use.

8.2.3 Alternate Foundations

Install support columns using screw piles or ballasts when required by the Foundation Designer.

8.2.4 Pile Tolerances

The DuraTrack™ DA system is designed with installation tolerances to facilitate ease of installation. The column tolerances defined below are the maximum tolerances allowed to enable proper system operation. These tolerances are superseded by any tighter, more precise tolerances placed on the foundations by the foundation engineer. These tolerances are not cumulative and are defined at the top of the columns and relative to the column plane and plan location. Some tolerances are interdependent on other tolerances. Make certain that the combination of these tolerances do not impact the mechanical assembly of the system.

8.2.5 Support Column

- A. Pile height tolerance: $\pm 0.5"$ from install plane
- B. Plan Location (NSEW): $\pm 0.625"$ N/S, $\pm 1.375"$ E/W

NOTE: AT TOP OF COLUMN

- C. Plumb: $\pm 2.5^\circ$ N/S
 $\pm 1.0^\circ$ E/W

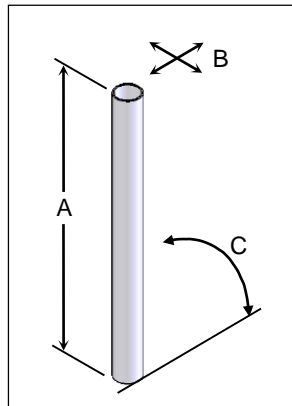

Figure 8-1 – Support Column Tolerance Reference Image

8.3 General Assembly Instructions

8.3.1 Torque Procedure

The general recommended procedure for torquing bolts is as follows:

1. Loosely install all bolts required for the connection.
2. Use a hand tool to “snug” all hardware.
3. Ensure proper alignment of all parts.
4. Alternate the bolt tightening order tighten the connection in increments until the proper torque is reached.
5. Verify that all bolts are secure and that none have loosened.
6. OPTIONAL: Mark each bolt head or nut with a permanent mark to indicate that it has been tightened to specified torque. Ensure the marking touches all layers of the connection, including the structure, for future reference.



Figure 8-3 – Torque-Marked Bolt

8.3.2 System Components

The major components of the DuraTrack™ DA tracker ship to site pre-assembled. Ensure all parts and assemblies have arrived on site in good condition prior to beginning installation.

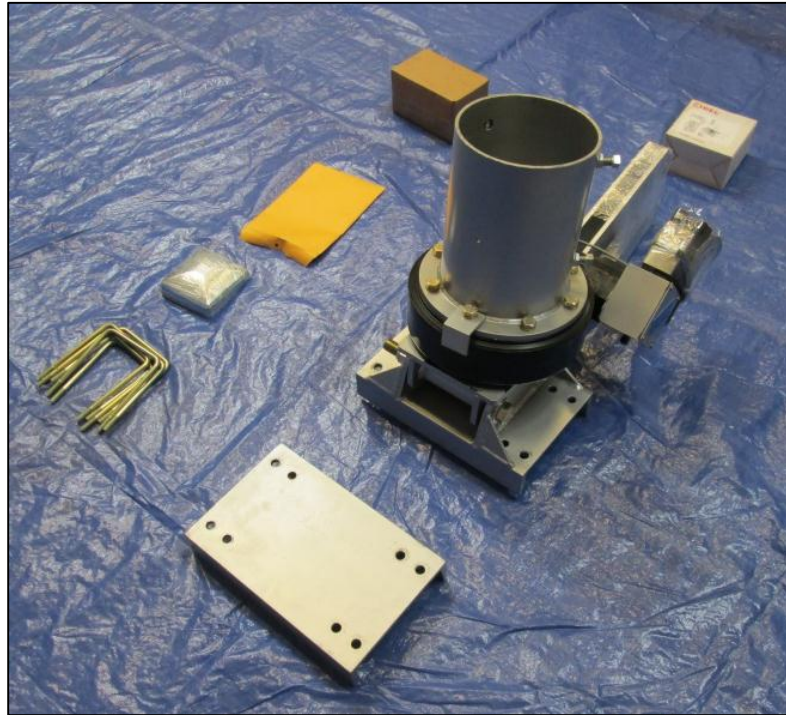

1. Actuator Assembly



2. Actuator Hardware



Actuator Assembly

- 1 - Motorized Actuator
- 1 - Hex Bolt .75-10x4.5, Zinc
- 4 - Washer, Flat .75, Zinc
- 2 - Nut, Hex .875-9, Zinc
- 1 - Nut, Nylon Insert .75-10, Zinc

3. Motorized Gearbox Drive



Motorized Drive Main Components

- 1 - Support Column Weldment
- 1 - Motorized Gearbox
- 1 - Controller
- 1 - Actuator Attachment Arm
- 1 - Lower Drive Arm Weldment
- 1 - Upper Drive Arm Weldment
- 1 - Upper Drive Arm Channel

4. Upper Drive Arm Channel



5. Channel Hardware



Upper Channel Hardware

- 8 - Hex Bolt .625-18x8, Zinc
- 8 - Nut, Nylon Insert .625-18, Zinc
- 16 - Washer, Flat .625 Zinc

6. Module Support Rails

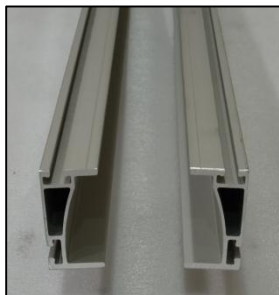

7. Angle Support with Hardware

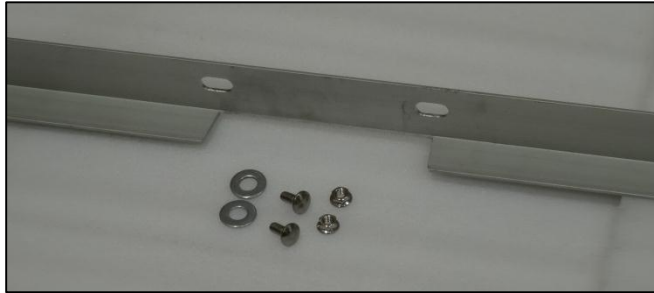

8. Angle Support Hardware



Angle Support Hardware

Carriage Bolt .313-20x.75 SST
Nut, Serrated Flange .313-20 SST

9. U-Bolts



Angle Support U-Bolt

U-Bolt, Square 1/2-13x6x7.5
(6" Torque Tube)

10. U-Bolt Hardware



U-Bolt Hardware

Washer, Flat .5 Zinc
Nut, Nylon Insert .5-13 Zinc

11. Module Mounting Hardware



Module Mounting Hardware

Carriage Bolt .25-20x.75 SST
Nut, Serrated Flange .25-20 SST

~or~

Carriage Bolt .313-20x.75 SST
Nut, Serrated Flange .313-20 SST

12. End Caps

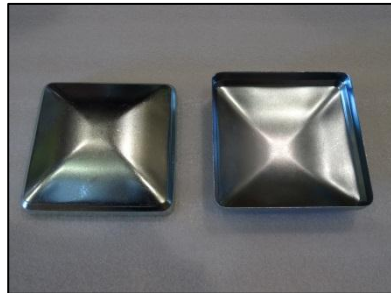

13. Controller with Remote Sensor

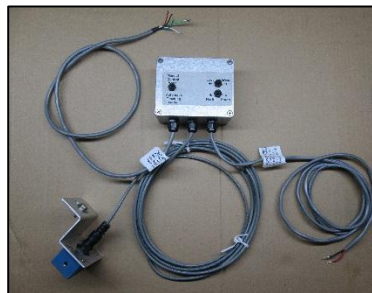

14. Torque Tube



9 Install DuraTrack™ DA Tracker Foundation and Support Column

9.1.1 Concrete Foundation Support Column Installation

1. RULE-OF-THUMB FOUNDATION DESIGN:
 - a. Equal length of column below ground as above
 - b. Minimum 3' diameter reinforced concrete foundation



CAUTION

Array Technologies, Inc. assumes no liability for tracker foundation installation. Consult the local Authority Having Jurisdiction (AHJ) or qualified professional to design the tracker foundation.

2. Cut at least two pieces of rebar or steel angle at lengths equal to the diameter of the foundation.
3. Weld the rebar (or drill holes into and insert rebar through) the underground portion of the pipe in an “X” pattern perpendicular to the pipe and parallel to the ground.
 - The rebar reinforcement is intended to prevent column rotation in the event of concrete shrinkage.

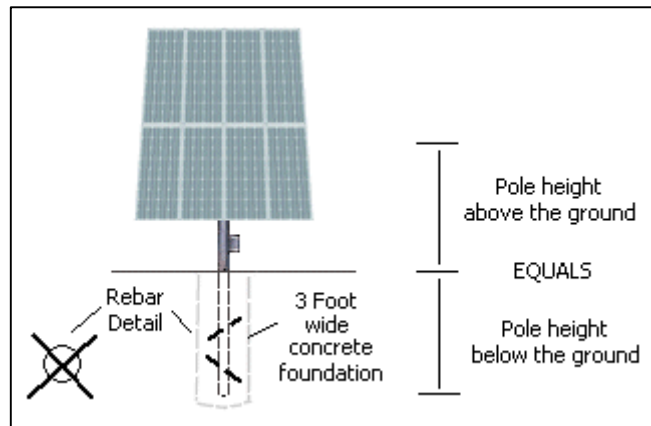

4. Using an auger, drill each foundation hole to the specified depth.
5. Add a minimum 6" layer of crushed rock in the bottom of each hole to prevent column corrosion from direct contact with wet soil.
6. Set support column into the hole onto the gravel layer.
7. Ensuring the support column is plumb, pour concrete around the column to fill the hole.
8. Pour sufficient concrete into the support column to cover the rebar reinforcements.

9. Ensure wet concrete has settled sufficiently, vibration may be required to eliminate air pockets.
10. Ensure columns are vertically plumb and supported in position while the concrete cures. (Refer to Section 8.2.5 for support column installation tolerances.)

9.1.2 Installation of equipment on the Support Column

1. Locate any equipment on the north side of the support column.
2. Allow vertical clearance of at least 1' from top of column.
3. Verify equipment will not interfere with tracker range of motion.

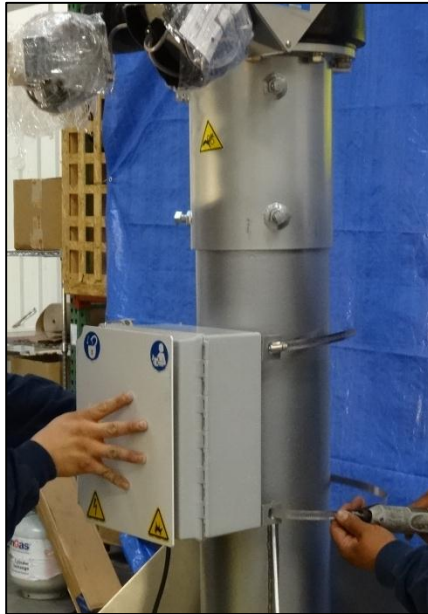

10 Install Motorized Drive and Actuator

The ATI DuraTrack™ DA motorized drive orientation is preset and referenced to Solar Noon.

Northern Hemisphere Installation: Orient the drive on the support column with the elevation arms pointing to “true north”.

Southern Hemisphere Installation: Orient the drive on the support column with the elevation arms pointing to “true south”.

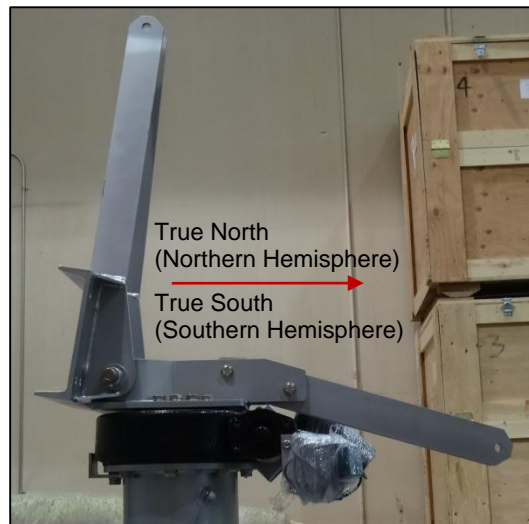

NOTE

True north and true south differ from magnetic north and south and are dependent upon geographical location. Any GPS-enabled device will accurately locate True North or True South, verify the device is set to “True North”.

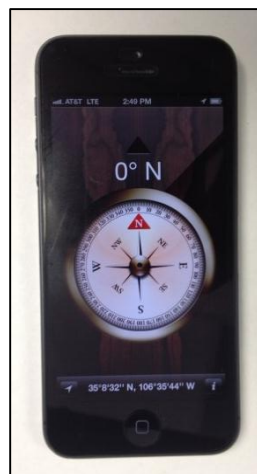

True North



Magnetic North

10.1 Install Motorized Drive

The motorized drive arrives secured to a pallet with all required hardware packed in and around the drive. Using a 3/4" wrench, remove the three bolts securing the drive to the pallet. Remove all hardware boxes from in and around the drive.



CAUTION

Do not remove protective shrink-wrap from around the Motor and Controller until drive, racking and module installation is complete.

The wrap prevents damage to the components and simplifies handling during installation.

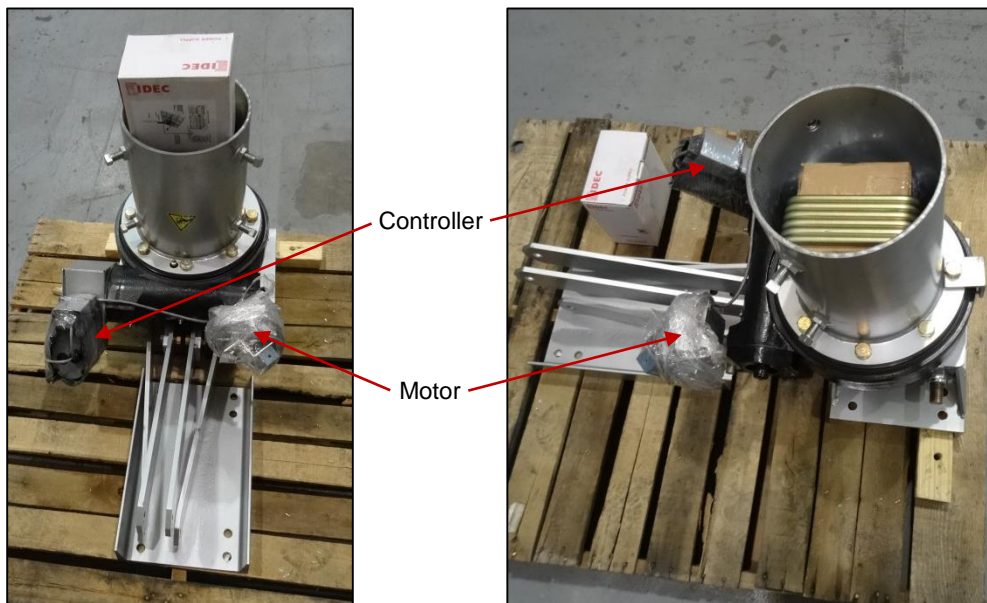

CAUTION

DO NOT USE THE MOTOR OR CONTROLLER AS "LIFT HANDLES".

Damage to the drive will result.

1. The motorized drive is packed on the pallet upside-down. Gently roll the drive onto a protected surface to orient correctly.
 - **DO NOT USE THE MOTOR OR CONTROLLER AS "HANDLES".**
 - Avoid placing any undue stress on the motor or controller, as damage may result.

2. Raise the upper elevation arm to a vertical position.
3. “Back out” or remove the 4 set bolts to prevent interference with the support column.

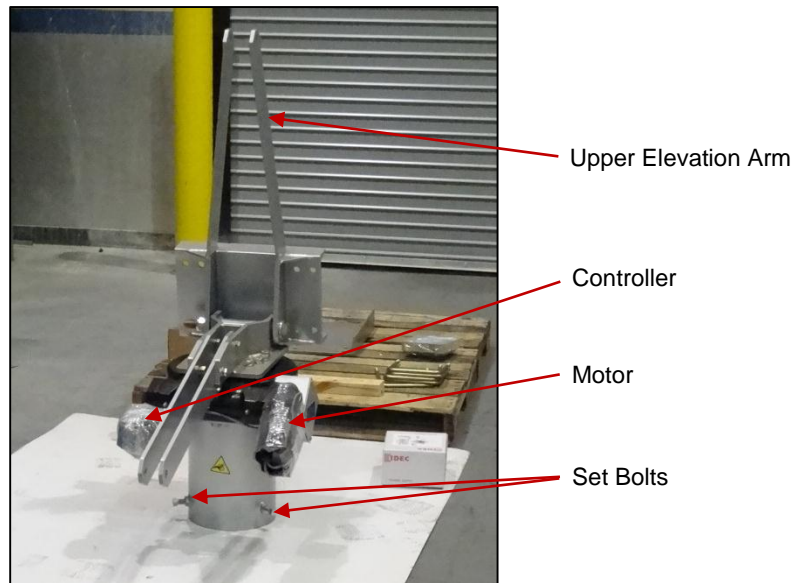

4. Thread a heavy-duty lifting strap around the drive lift brace.

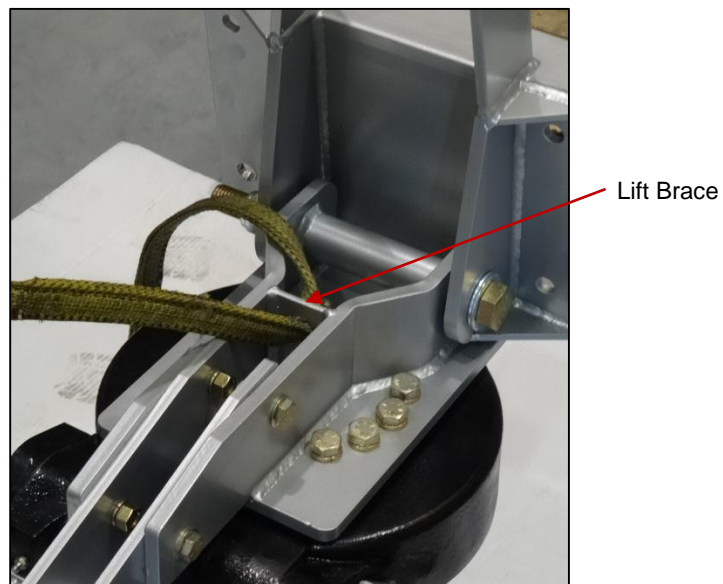

TIP

Use a forklift or other appropriate machinery to move and install the motorized drive. It can make the installation process safer, easier, and more efficient.

5. Gently lift the drive and position above the support column. Align the drive and column.



WARNING:
PINCH POINT HAZARD

6. Guide the drive while lowering it into position onto the support column. Once the drive is fully seated, remove the lift strap.



7. Install the drive set screws and snug. Do not torque at this time. Adjust all screws to show the same amount of thread when tightened, placing even pressure on the support column.



8. Orient the drive with the lower elevation arms pointing True North (or True South).
9. Reference Section 8.3.1 - Torque Procedure.
10. Torque the set screws to 85 ± 12 ft-lbs (115 ± 16 Nm) using a 3/4" 12-point deep well socket.



11. Aligning the bit with the pre-drilled hole in the drive housing, drill through the support column using a 3/8" metal drill bit.



12. Install the 3/8" roll pin, penetrating both the drive housing and the support column. Use a rubber mallet to prevent damage to the drive housing.



TIP

Alternately, the support column may be tapped to 3/8"-16 using a 5/16" tap and a 3/8" bolt utilized in place of the roll pin.

13. The drive is fully installed on the support column.

10.2 Install Actuator

The ATI DuraTrack™ DA Actuator extension and contraction limits are preset and require no adjustment. Avoid unscrewing the inner actuator tube during installation; to do so may disturb the preset limits. Do not adjust the lower eye clamp location nor attempt to tighten the clamp bolts, this can result in damage to the actuator and/or tracker malfunction.

1. Lower the upper elevation arm to the down position.
2. Remove the lower arm attachment hardware. Position the lower actuator bracket swivel mount between the lower arms and replace the attachment hardware. Do not tighten the hardware at this point.
3. Remove the upper arm attachment hardware. Position the upper actuator bracket swivel mount between the upper arms and replace the attachment hardware.

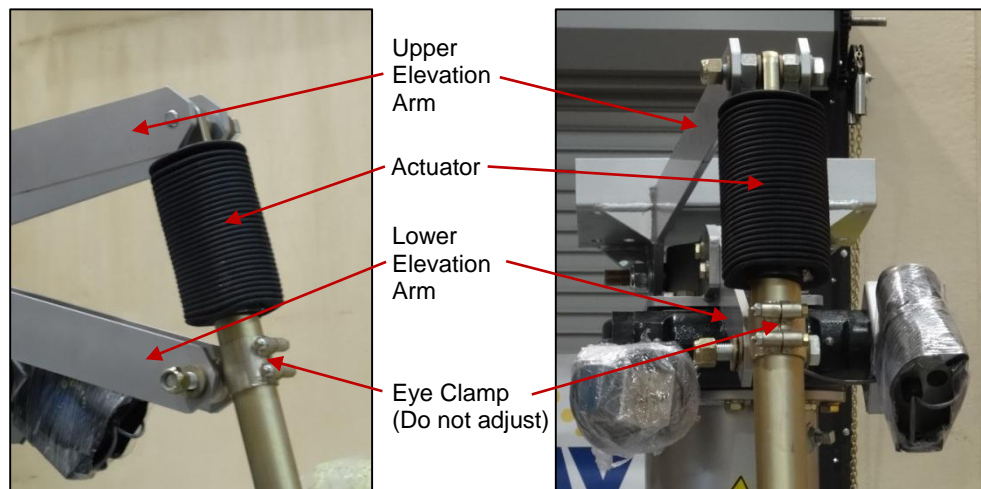

4. Using 1-1/8" wrench and 1-1/16" socket, torque upper and lower bolts to 70 ± 5 ft-lbs (95 ± 7 Nm). The Actuator is now completely installed.



11 Install Torque Tube and Module Support Frame Structure

11.1 Install Torque Tube

The DuraTrack™ DA square torque tube is the support for the module mounting frame structure. The torque tube must be centered on the support column.

1. Position the torque tube on low supports, allowing approximately 1" gap between ground surface and tube.
2. Measure the length of the torque tube and mark the center point.

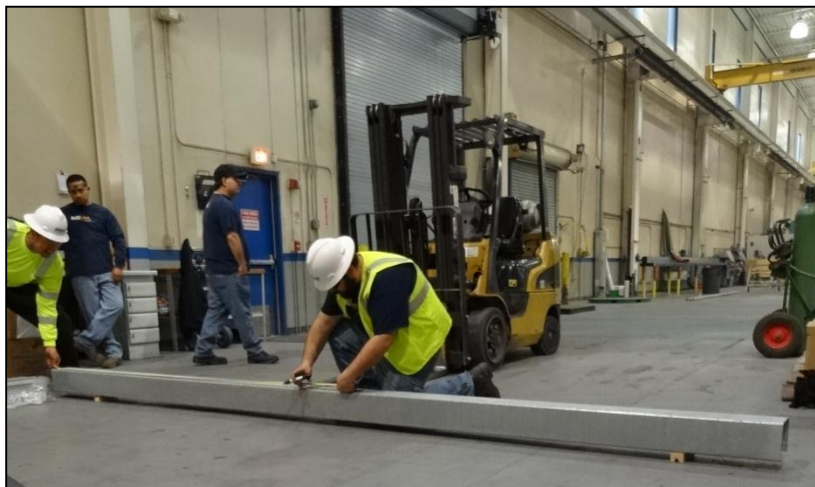

3. Attach a pair of heavy-duty lifting straps to either side of the center mark at the width of the forks.



- Lift and position the torque tube to rest above the drive lower channel.

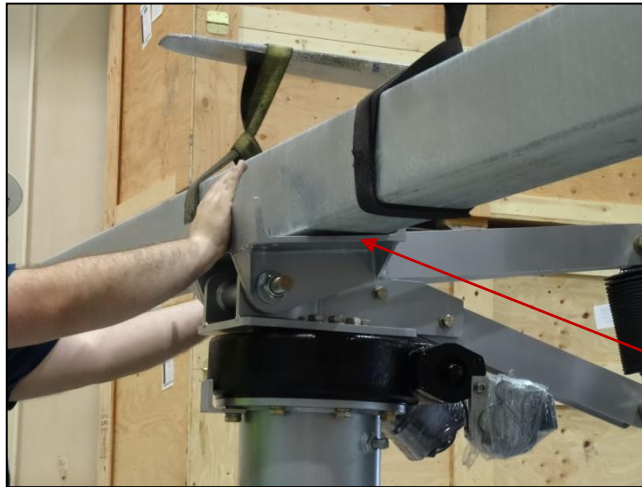

**WARNING:
PINCH POINT HAZARD**

Lower Channel

- Verify the torque tube is centered east-to-west on the drive channel and set the tube atop the drive lower channel.
- Place the drive upper channel atop the torque tube, aligning the upper and lower channels.
- Install 8 channel bolts, nuts and washers. Do not torque at this time.
- Remove lifting straps.
- Verify the upper and lower channels are aligned and square.
- Torque the bolts to 110 ± 10 ft-lbs (149 ± 14 Nm) using torque wrench with 15/16" socket and 15/16" wrench. (Reference Section 8.3.1 - Torque Procedure.)

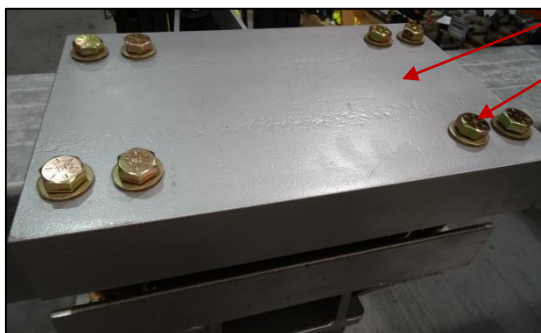
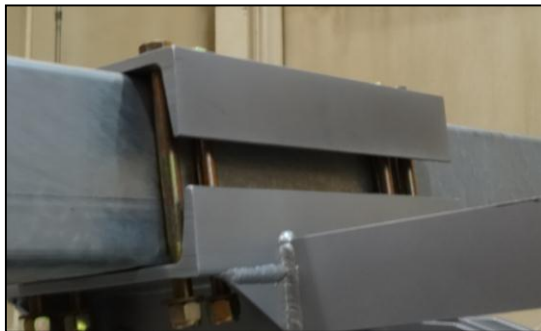

Upper Channel

Channel Bolt

Torque all 8 bolts

11.2 Install Module Support Frame Racking

ATI DuraTrack™ DA tracker frames are designed for efficient and secure mounting of modules in a rectangular grid. Vertical Module Mounting Rail pairs support the modules in landscape orientation. One or more vertical module rail assemblies are attached to the horizontal torque tube to complete the array.

The Module Mounting Rails will be placed according to the final array design. For arrays designed with an odd number of vertical module rail assemblies, the center assembly is centered above the drive. For arrays designed with an even number of vertical rail assemblies, the two center assemblies meet above the drive.

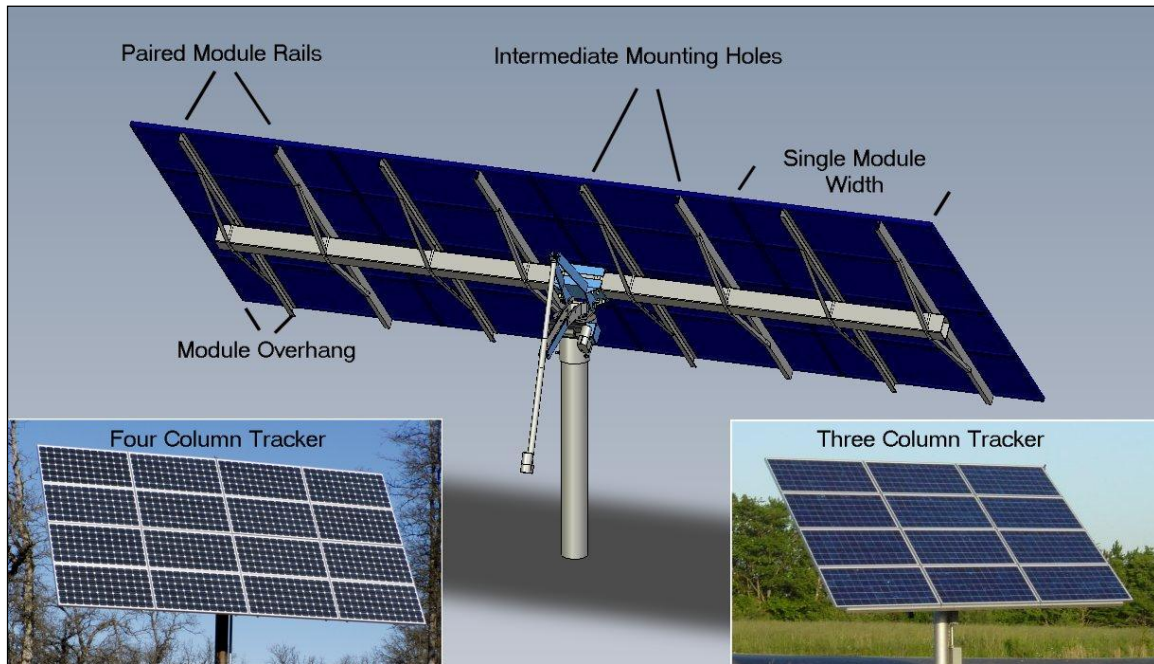

The support frame consists of Module Mounting Rails and Support Angles mounted onto the torque tube using U-bolts, washers and nuts.

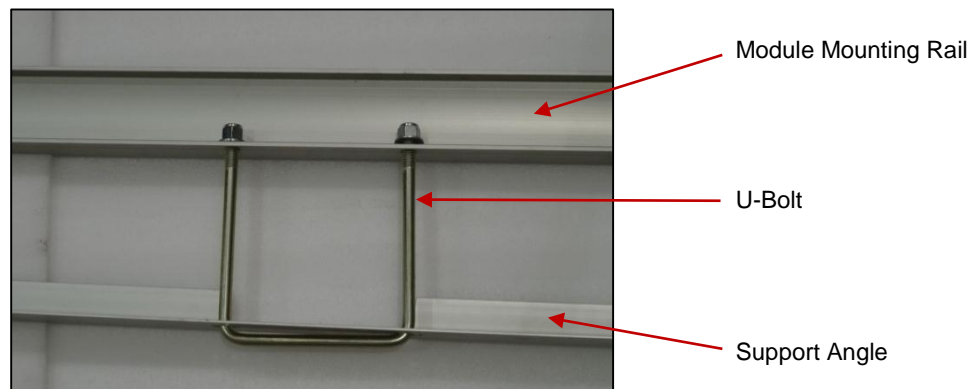

11.2.1 Support Rack Installation

1. Insert a U-Bolt into the pre-drilled holes in the Support Angle.

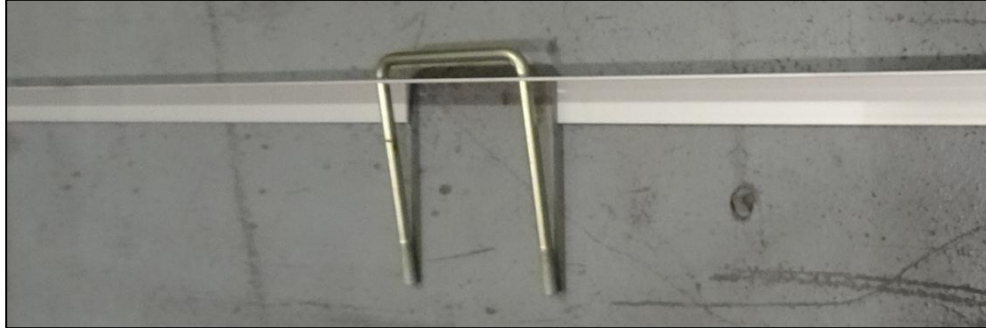

2. Pre-install the Support Angle hardware on the Module Mounting Rail. Finger-tighten only.

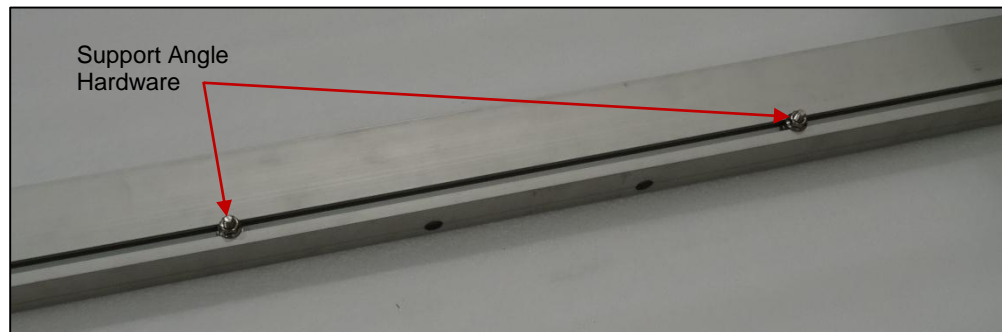

3. Position a Module Mounting Rail on the torque tube with mounting holes to either side of tube.
 - Verify correct orientation and location of Module Mounting Rail. A pair of rails is orientated so that the module attachment channels face upward and the angle attachment channels face outward.

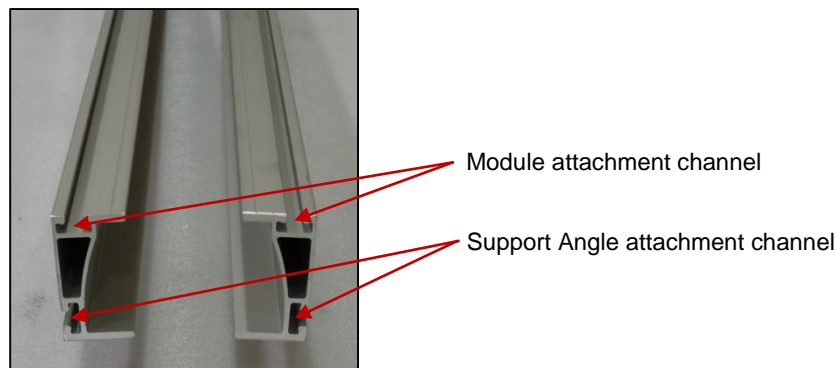

4. Guide the U-bolt with Support Angle up and around the torque tube from the bottom, aligning the U-bolt threads with the holes in the Module Mounting Rail. (Refer to Section 12 [Attach Modules](#) for Module Support Rail placement guidelines.)



5. Install ½” washers and ½” nuts to attach the U-Bolt and Support Angle to the Module Mounting Rail. “Finger-tighten” only, do not tighten or torque U-Bolt hardware at this time.



TIP

Do not fully tighten the support frame hardware until after modules have been mounted. Allowing a small amount of “play” in the frame assembly will result in efficient adjustment of the support rails during module installation.

6. Loosen the pre-installed Support Angle hardware and position to end of Support Angle.
 - If hardware has slipped off the Module Mounting Rail, slide a bolt into the outer channel of the rail and slide to the Support Angle.

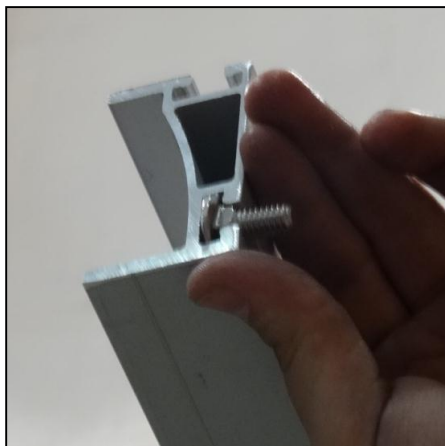

7. Gently raise one end of the Support Angle to meet the Module Mounting Rail and attach to bolt.



8. Attach a flange nut to secure the Support Angle to the Module Mounting Rail. Repeat process for opposite end of Support Angle.



9. Repeat process for remainder of Module Mounting Rails. Verify correct rail orientation prior to installing. Space rails in accordance with the module model and array design.
10. Install an End Cap at each end of torque tube.

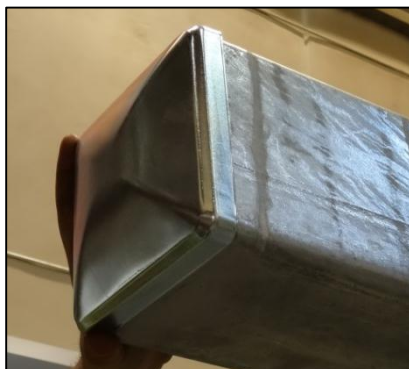

12 Attach Modules

The ATI DuraTrack™ DA Tracker frames are designed to accommodate most commercially available solar modules. The modules are attached to the Mounting Rails using the intermediate mounting holes, located approximately $\frac{1}{4}$ the length of the module frame from each corner.

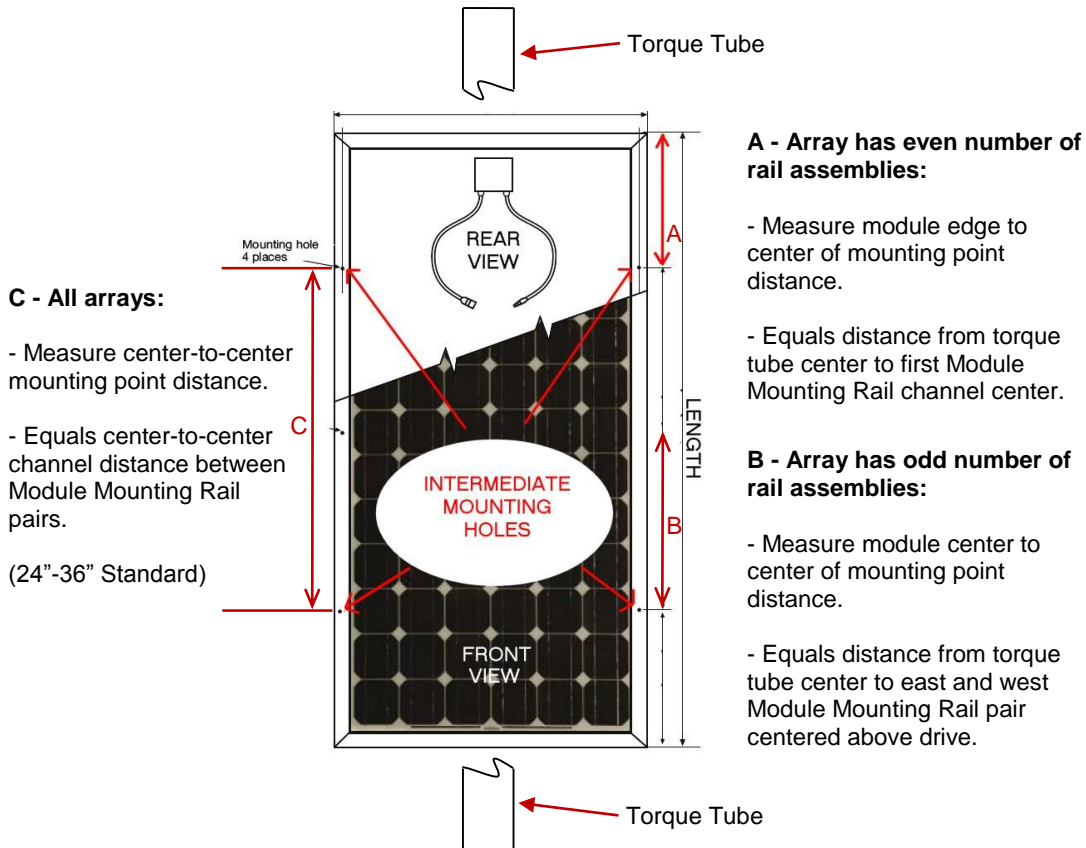

12.1 Module Installation

ATI provides module mounting nuts and bolts with a serrated face on each which, when properly tightened, "bite" into the module frame. No washers are required.

1. Pre-install the nut and bolt hardware in each module intermediate mounting hole. Do not fully tighten the bolt. Allow sufficient play to enable the bolt head to slide easily into the support rail track.
2. Measure the center-to-center distance between the mounting bolts.
3. Measure the center-to-center distance between the Module Mounting Rail channels; adjust to match the module mounting hardware distance (typically 24" – 36").



Measure center-to-center mounting point distance. (Typically 24"-36")

4. Verify the tracker is in the "stow" or horizontal position.
5. Slide the module leading edge bolt heads into the Module Mounting Rail channel.
6. Push the module forward, sliding the second set of bolt heads into the Module Mounting Rail channel.
7. Properly position the module and snug the hardware. Do not tighten or torque at this time.



8. Repeat installation for all modules.
9. Verify even spacing between modules (typically ¼" to ½"). **Adequate spacing between modules is required to accommodate thermal expansion.**

10. “Square up” the entire support frame structure.
11. Tighten and torque the Mounting Rail U-Bolt hardware to 70 ± 5 ft-lbs (95 ± 7 Nm).
12. Tighten and torque the Angle Support hardware to 10 ± 2 ft-lbs (14 ± 3 Nm).
13. Tighten and torque the module mounting hardware to:
 - a. 10 ± 2 ft-lbs (14 ± 3 Nm) - 5/16” Hardware
 - b. 5 ± 1 ft-lb (60 ± 12 in-lb ; 7 ± 1 Nm; 68 ± 14 dNm) – 1/4” Hardware
14. Route and secure all module wiring in accordance to module specifications.



WARNING

ATI strongly recommends allowing only certified electricians to install electrical components in accordance with specifications provided in the installation Assembly Drawings and in accordance with local codes and regulations.

12.2 Grounding Suggestions



WARNING

Improper installation of electrical or grounding systems could result in serious injury or damage to equipment. **DO NOT USE ANY ATI STRUCTURAL CONNECTIONS AS GROUNDING POINTS.**

ATI recommends all grounding and wiring methods be designed and installed in accordance with the National Electrical Code, ANSI/NFPA 70.

Standard base structure designs use standard steel or zinc-coated mounting hardware with anodized aluminum rails. If the PV modules are not individually grounded, the module ground currents can flow through frame assemblies and may cause dissimilar metal corrosion. All module grounding methods must be approved by the module manufacturer and comply with applicable codes.

The following grounding clip examples are structurally compatible with the ATI Universal Racking system. Any grounding method must be approved by the local Authority Having Jurisdiction (AHJ) and the module manufacturer prior to starting construction:

1. Standard module grounding lugs.
 - a. Placed at standard grounding holes, or
 - b. Placed at module mounting holes, if allowed by the module manufacturer.



Standard Grounding Lug Examples



NOTE

ATI does not provide grounding hardware. Grounding approval must be provided by the module manufacturer and AHJ (Authority Having Jurisdiction) prior to installation.

- 2. Amphenol Helio
 - a. Amphenol DS-52-1

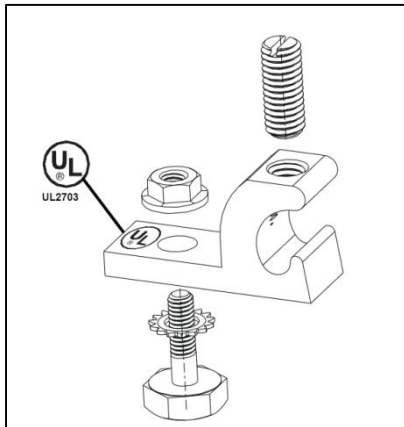

Amphenol Grounding Solution

13 Install Dual Axis Tracker Controller Components

13.1 Controller Function, Features and Specifications

13.1.1 ATI Controller Function

ATI Solar Trackers utilize a patented, closed loop, optical sensing system to locate and track sun's position. The light sensors are mounted on the remote chassis and feed information to the control electronics – direct, diffused and total sunlight available at each sensor as well as the differential amount of sunlight available at opposing sensors. Based on this information, the controller seeks to equalize the sunlight received by opposing sensors for each axis.

The controller circuitry automatically adjusts the tracker sensitivity according to the total amount of light received by the sensors. The controller increases tracker sensitivity with increased direct sunlight and decreases sensitivity with scattered or diffused light; enabling the tracker to eliminate undue “hunting” in cloudy or overcast conditions.

If the tracker controller is connected to a battery bank or constant power source, the controller senses sunset and returns to the sunrise position. If it is powered directly from the PV array, the tracker returns to sunrise at first morning light. The controller uses energy integration circuitry, enabling the tracker to move with as little as 20ma of available current.

The tracker controller sends polarized signals to the DC gear motor instructing the motor to rotate the PV array to a perpendicular position relative to the sun's rays. The DC motor responds to the polarity of the controller signals; one polarity instructs movement in the forward direction, reverse polarity instructs movement in the opposite direction. Once the tracker is positioned to the “on track” position, the controller electrically “brakes” the motor to stop movement, resulting in greater tracking accuracy.

The controller prioritizes the azimuth (east/west) axis. The elevation axis will not function until the azimuth axis is on track; once the azimuth axis has locked onto the sun and stops moving, the elevation axis adjusts. However, simultaneous azimuth and elevation motion is possible if the controller is powered from a battery bank.

The DC gear motor is a compact, 1/15 HP, low voltage gear motor with gearing designed to prevent high winds or other forces from driving the tracker from optimum alignment.

13.1.2 ATI Controller Standard Features

- Pre-installed, drive-mounted controller allows maximum accessibility.
- Sensor mounts independently of the main chassis.
- Dip switches to test the Azimuth and Elevation Limits.
- Dip switch to set nighttime Elevation (stow) position.
- Light sensitivity adjustment potentiometers for Azimuth and Elevation.
- 5-amp automotive spade type fuse (ATO).
- Controller outputs short circuit protected and limit the output current to 3 amps.
- Self-resetting thermal fuse shuts off power to tracker motors in the event of obstruction.
- Filtering protects the tracker motor against "noisy" PWM charge controllers.
- Improved lightning protection.

13.1.3 ATI Controller Specifications

- Input voltage range 23 to 50 volts DC.
- Power consumption less than 10 watt-hours per day.



WARNING

DO NOT ENERGIZE THE TRACKER UNTIL INSTALLATION IS COMPLETE. READ AND UNDERSTAND ALL INSTRUCTIONS IN THIS GUIDE PRIOR TO ENERGIZING THE ATI TRACKER. ATI strongly recommends allowing only certified electricians to install electrical components in accordance with specifications provided in the installation Assembly Drawings and in accordance with local codes and regulations.

13.2 Controller Connection Ports

1. Carefully remove protective shrink-wrap from the controller and motor. Use care to avoid stressing pre-installed wiring.



2. Carefully uncoil and check each wire. Contact ATI if any pre-installed wiring appears loose or damaged.

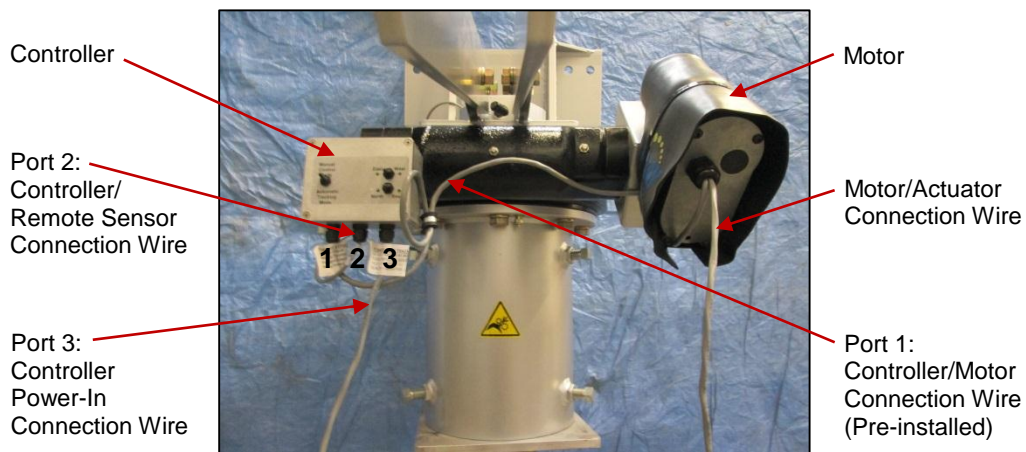

3. Port 1: Power out to the Actuator and Drive Motors. The Controller arrives with connections to the Actuator and Drive motors pre-wired.
4. Port 2: Power in from the Remote Sensor. Connect to Remote Sensor output port after installation, Section 13.3.
5. Port 3: Power in to tracker Controller. Connect to power source following applicable steps in Section 14.

13.3 Install the Remote Sensor

ATI Solar Trackers utilize a patented, closed loop, optical sensing system to locate and track the sun's rays. The remote sensor must be installed on a module at the top center of the array, in an unobstructed location.

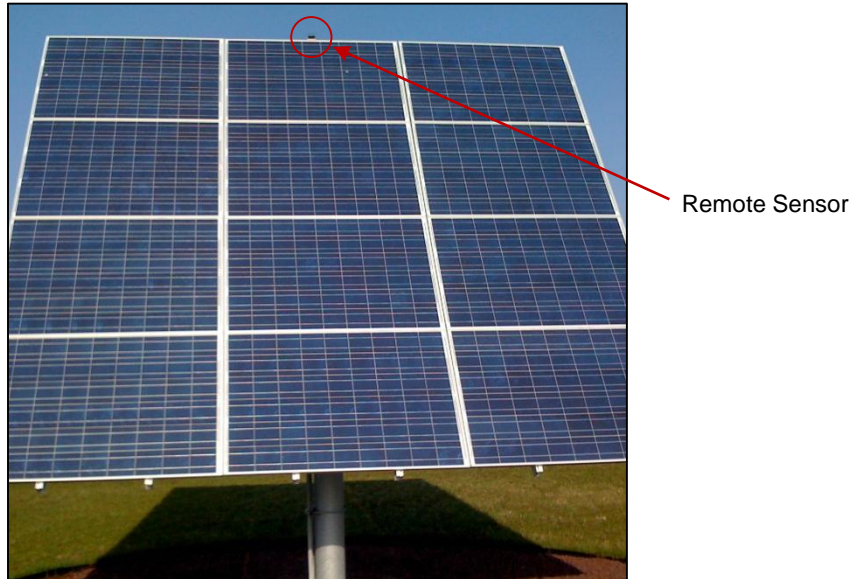

CAUTION

Do not damage the clear sensor on the top of the Remote Sensor housing. Damage to the sensor can result in improper system function.

13.3.1 Remote Sensor mechanical installation

1. Determine the Remote Sensor installation location:
 - a. Verify the Sensor is above the plane of the array.
 - b. Verify the Sensor is at or near the center of the array.
 - c. Verify the Sensor has an unobstructed view of the sky.



NOTE

Most modules arrive from the manufacturer with a pre-drilled hole in the back of the frame. Use the pre-drilled holes for sensor mounting. Drilling a hole in the module frame may void the module warranty.

2. Drill a ¼" mounting hole in the back frame of the selected module.
 - a. Place the remote sensor bracket at the desired location on the frame.
 - b. Mark the mounting hole location.

- c. Place a wood block between the frame and solar panel to prevent damage to the panel.
- d. Using a ¼” bit with a drill stop, drill hole through the frame at the marked point.

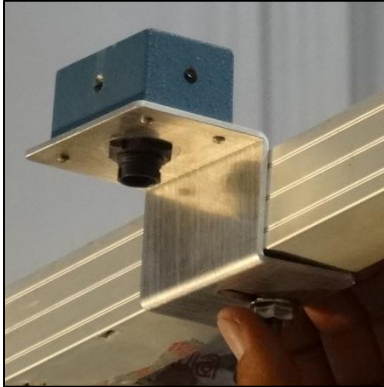

3. Install the sensor bracket using 1 each ¼” Stainless Steel Bolt, ¼” Stainless Steel Flat Washer and ¼” Stainless Steel Lock Nut.
4. Torque the hardware to 5 ± 1 ft-lbs (60 ± 12 in-lbs; 7 ± 1 Nm; 68 ± 14 dNm). (Refer to Section 8.3.1 Torque Procedure)

13.3.2 Remote Sensor electrical connection

5. Plug the Remote Sensor wire into the back of the Remote Sensor.

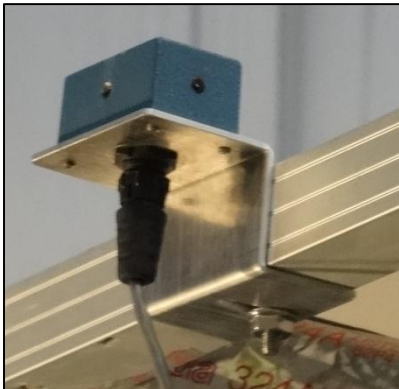

6. Route the sensor wire along the back of the array to the controller.
7. Connect the remote sensor wire to the controller.
 - a. Align the tongue of the molded sensor wire connection with the groove in the controller connector (center port).
 - b. Push the sensor wire connector fully into the controller connection port.
 - c. Rotate the locking ring to secure the connection.
8. Secure the entire length of the sensor wire to the array frame, allowing sufficient slack for full tracker range of motion.

14 Power Connection to the Tracker Components

14.1 Power Connection to the Elevation Actuator



WARNING

Do not apply power to the actuator until it has been securely bolted into place. Doing so will destroy the preset limit switch settings. ATI strongly recommends allowing only certified electricians to install electrical components in accordance with specifications provided in the installation Assembly Drawings and in accordance with local codes and regulations.

14.1.1 DC input polarity during normal operation

The actuator motors are DC motors. The polarity of the DC power coming from the controller will dictate the direction and movement of the actuator. Standard DC color codes are “relative” when applied to the actuator motor connections.

Extension (Tilt Array Up)	Red +	Black -
Retraction (Lay Array Flat)	Red -	Black +



1. Slide the actuator cover up the actuator shaft away from the motor.
2. Remove the screws in the motor cap.



3. Remove the motor cap. The plastic strain relief may have been inverted and stowed inside the cap to protect it during shipping.
4. Release the strain relief and snake the actuator power wire through cap and strain relief.

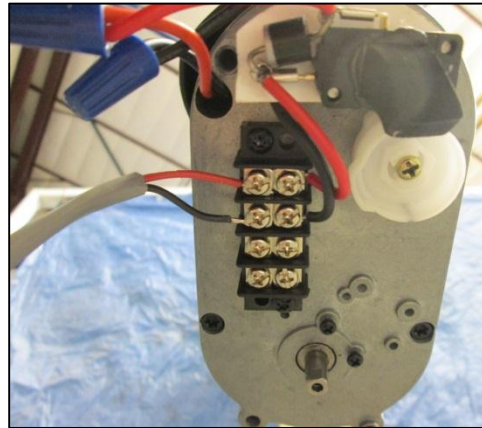

5. Connect Wire Terminal 1 (top) – Controller Red to Actuator Red
6. Connect Wire Terminal 2 (bottom) – Controller Black to Actuator Black

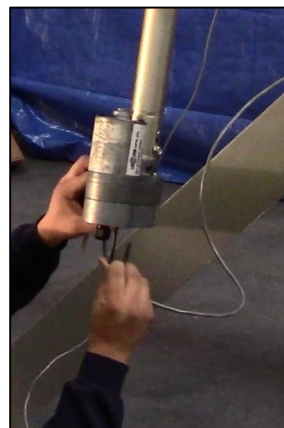

7. Carefully replace the motor cap and screws.



8. Tighten the motor cap screws and reseat the strain relief.

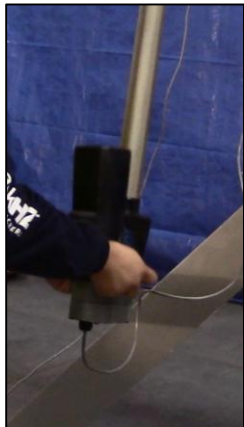

9. Slide the actuator cover down the shaft over the motor.

14.2 Power Connection to the Tracker Controller

Array Technologies recommends powering the ATI Tracker Controller from a battery bank or grid-tied power source. The tracker has ± 120 degrees of azimuth tracking available and will return to the East at sunset. Additionally, the built-in sensor override features are always available when there is continuous power to the controller.



NOTE

The azimuth-tracking limit switches are preset at the factory to accommodate the maximum range of East-West azimuth tracking.

Powering the controller from the array will limit the tracker to only 180 degrees of available azimuth tracking arc. Azimuth Motor limit switch cams will need to be reset to reduce the East-West travel. Additionally, the built-in sensor override features will be available only during daylight hours.



CAUTION

Do not power the controller from the array. Azimuth tracking will be significantly reduced and additional system adjustments will be required.

The controller is pre-mounted to the drive head at the factory. The remote sensor and azimuth motor connections are also pre-wired and tested.



WARNING

Ensure the installer provides the appropriate fusing or DC breaker to protect any long wire runs and to properly disconnect to the controller power input. ATI strongly recommends allowing only certified electricians to install electrical components in accordance with specifications provided in the installation Assembly Drawings and in accordance with local codes and regulations.

14.2.1 Powering the ATI Controller from a constant power source



TIP

ATI recommends powering the tracker controller from a constant power source, either a battery bank or grid-tied switching power supply.

1. 24 volt DC battery bank power source:

- Connect the controller power-input leads directly to the main 24-volt battery bank.
- The positive lead running from the battery bank to the power input of the controller must be fused with a 5 amp, current limiting, DC-rated fuse or equivalent DC breaker.
- Failure to fuse the input power wire at the battery bank may create a potential fire hazard.



WARNING

Failure to fuse the input power wire at the battery bank may create a potential fire hazard. ATI strongly recommends allowing only certified electricians to install electrical components in accordance with specifications provided in the installation Assembly Drawings and in accordance with local codes and regulations.

2. 48 volt DC battery bank power source:

- An ATI Voltage 48 to 24 VDC Converter is required to reduce the voltage to the tracker controller and motors.
- The positive lead running from the battery bank to the power input of the controller must be fused with a 5 amp, current limiting, DC-rated fuse or equivalent DC breaker.
- Failure to fuse the input power wire at the battery bank may create a potential fire hazard.



WARNING

Do not power the controller directly from a 48 VDC battery bank.

The "working voltage" of a 48 VDC bank exceeds the controller's 50 VDC maximum input rating. A 48 VDC bank can easily reach 59 VDC during an equalize cycle.

3. Grid-tied AC to DC switching power supply:

- A Switching Power Supply (WPS5RSF-24 or equivalent) is required to convert AC voltage to 24 VDC.

14.2.2 Battery Bank to Controller Circuit simplified wiring diagram:

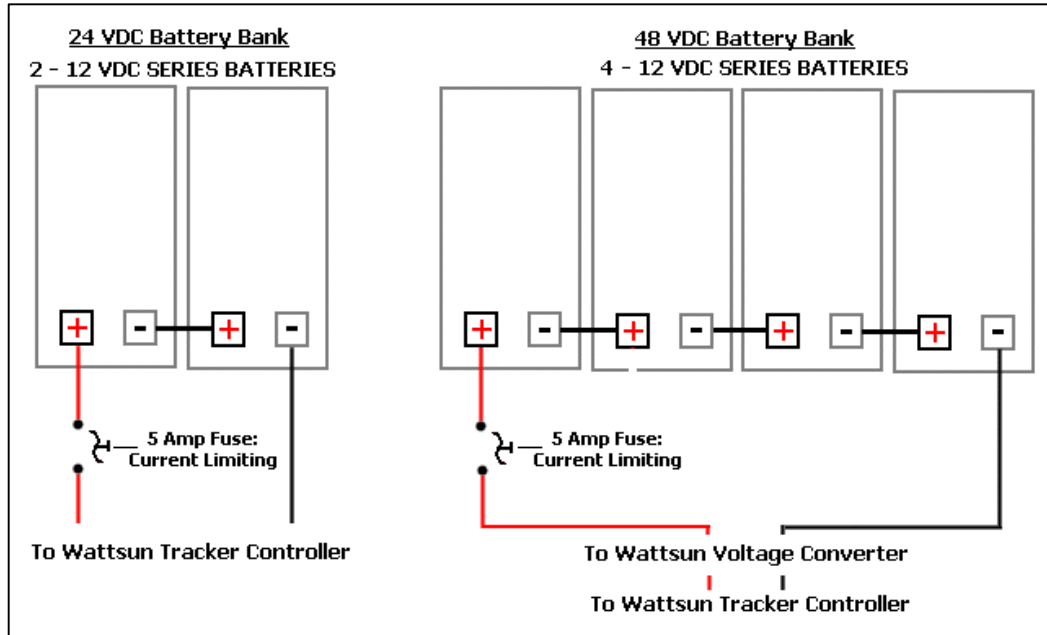

14.2.3 Controller Diagram:

Interior View of the Dual-Axis Controller for Azimuth Trackers.

Refer to Section 15.1 – Tracker Controller Operation and Dip Switches.

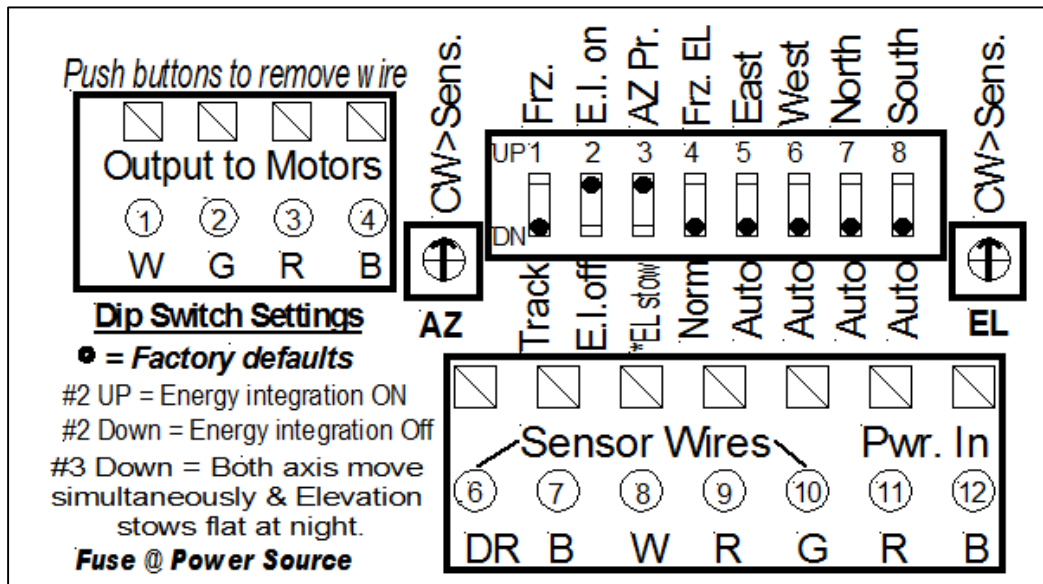

15 Tracker Preferences and Operation

15.1 Manual Control

The Manual Control Option allows bypass of automatic tracking and manual movement of the tracker East, West, North, or South. The Manual Control Option is typically pre-installed on ATI trackers, but is also available as an upgrade kit that can be installed in the field.



15.1.1 Manual Control Function:

The Manual Control Option requires that power be available to the ATI Tracker Controller. If controller power is provided by a main battery bank, the manual controls can be used day or night. If the tracker controller is powered by the array, use of the manual controls will be limited to the daylight hours.

15.1.2 Manual Control Switch Operation:

1. **Automatic / Manual**
 - a. Down = Auto Tracking
 - b. Up = Manual Tracking.
2. **East / West**
 - a. Left = Track East
 - b. Right = Track West.
3. **North / South**
 - a. Up = Track South (elevate)
 - b. Down = Track North (flatten).

15.1.3 High Wind Locations

To reduce wind loading in the event of very strong or tropical winds, rotate the tracker to the full North position; the array flattens to the horizontal stow position of 5°.

15.1.4 Heavy Snow Locations

To remove snow build-up on the array, rotate the tracker to the full South position, the array elevates to a 60° angle.

15.2 Tracker Controller Operation and Dip Switch Options

Your tracker controller is preinstalled and ready to operate upon the connection of a power supply. The following procedure tests the operation of the controller, verifies the full range of motion of the tracker and instructs in setting field selectable options. Options allow the tracker to be turned on and off or set to bypass the Energy Integration Circuit; the Dual Axis Tracker has variable options for nighttime “stow”; or the auto-tilt function may be disabled entirely.

15.2.1 Survey the work area:

The tracker range of motion will be tested. The tracker is set to Auto-Track and will begin moving as soon as power is connected to the controller.

1. Verify there are no obstructions in the path of the tracker when it begins to rotate.
2. Inspect the wiring from the array to the controller and your junction box.
3. Verify all wire service loops are of sufficient length.
4. Verify all wires are free from binding at all pivot points.
5. Verify sufficient wiring slack to accommodate full tracker movement in all directions.

15.2.2 Remove the controller cover:

1. Loosen the 4 Phillips bit machine screws and remove the metal cover of the controller. Keep the cover and gasket free of dirt.
2. Loosen the wire strain relief grommets and gently lift the upper panel.

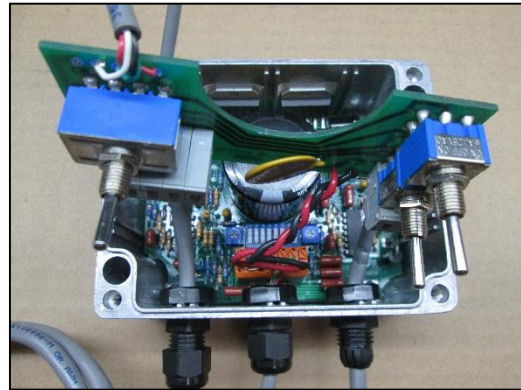

3. The numbered dip switches are now accessible.

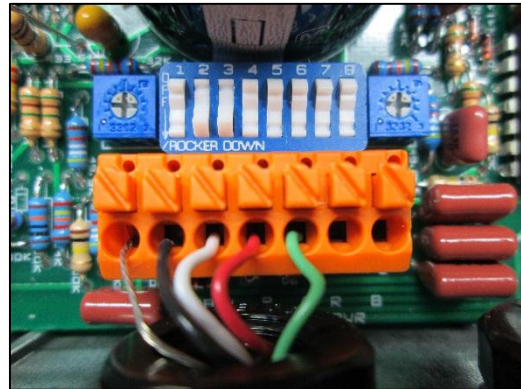

15.2.3 Perform Tracker Controller Test

1. **Switch#1- Auto Tracking:** ON when pushed in at the bottom.
Depress the top rocker of Dip Switch #1 to the UP position to temporarily freeze the tracker position.
Push in at the bottom to return to Auto Tracking when the controller test is complete.
2. **Switch #2- Energy Integration:** ON when pushed in at the top.
Always leave UP (ON position) unless the tracker is being powered from a nearly depleted 24VDC battery bank.
The down position (OFF position) bypasses the Energy Integration Circuitry. This allows the tracker to operate when the battery voltage is below 23.5 VDC
3. **Switch #3 – Dual Axis, Maintain Array Tilt at Night:** ON when pushed in at the top.
The Azimuth Drive motor operates 1st and the Elevation actuator operates 2nd. The array maintains the sunset tilt at night; the tilt may be shallow on overcast days.
When the switch is pushed in at the bottom, both tracker motors can operate at the same time and the array will LAY FLAT at night. Use only in situations where there are high winds and no snow during the evening hours.
4. **Switch #4: Dual Axis, Elevation Tracking:** ON when pushed in at the bottom.
The tracker will automatically track the sun up and down in the sky.
OFF when the switch is pushed in at the top, the elevation tracking is stopped. Use in high-latitude sites where the days are short, the sun is low in the sky and snow loading on the array is an issue.
5. **Switch #5: East Override:** OFF when pushed in at the bottom.
Manually move the tracker East by depressing the top of Dip Switch #5. The tracker will track to the East and stop once the Limit Adjustment Cam touches the limit switch.
Return it to OFF position for AUTO TRACKING.
6. **Switch #6: West Override:** OFF when pushed in at the bottom.
Manually move the tracker West by depressing the top of Dip Switch #6. The tracker will track to the West and stop once the Limit Adjustment Cam touches the limit switch.
Return it to OFF position for AUTO TRACKING.
7. **Switch #7: North Override:** OFF when pushed in at the bottom.
Manually move the tracker North (de-elevate) by depressing the top of Dip Switch #7. The tracker will "flatten out" and stop once the elevation actuator's internal limit has been reached.
Return it to OFF position for AUTO TRACKING.

8. **Switch #8: South Override:** OFF when pushed in at the bottom.

Manually move the tracker South (elevate) by depressing the top of Dip Switch #8. The tracker will track to the North and then stop once the elevation actuator's internal limit has been reached.

Return it to OFF position for AUTO TRACKING.

















15.2.4 Setting the Sensor Light Sensitivity:

The sensor sensitivity is preset at the factory. Inside the controller chassis are two adjustment potentiometers for light sensitivity. They are a single-turn pot: clockwise rotation equals greater sensitivity, counter-clockwise rotation equals lower sensitivity. Only qualified personnel should perform this adjustment. Do not turn more than ½ turn in either direction.

15.2.5 Interior Fuse

Replaceable 5-Amp automotive spade type fuse (ATO). Do not replace with a larger amp rated fuse. Gently pull the fuse out of the holder to inspect or replace. It is usual to see a small spark when reconnecting the fuse. A 7.5-Amp fuse is the maximum fuse allowed.

*Default Tracker Setting

Switch #1 Auto Tracking		ON Position*	Auto Tracking Enabled
		OFF Position	Auto Tracking Disabled <i>Use off setting to temporarily freeze tracker position.</i>
Switch #2 Energy Integration		OFF Position	Bypass the Energy Integration Circuitry <i>Use off setting to allow the tracker to operate when the battery voltage is below 23.5 VDC.</i>
		ON Position*	Energy Integration Circuitry Engaged <i>Use off position only if powered by nearly depleted battery bank.</i>
Switch #3 Stow - Maintain Tilt		OFF Position	Drive motor and Elevation Actuator perform in unison; tilt is 0° (flat) at night. <i>Use off setting only in high wind and <u>no snow</u> conditions.</i>
		ON Position*	Maintain Tilt Enabled Drive motor and Elevation Actuator perform in sequence; tilt angle at sunset is maintained at night.
Switch #4 Elevation Tracking		ON Position*	Elevation Tracking Enabled
		OFF Position	Elevation Tracking Disabled <i>Use off setting for high-latitude sites (low sun angle) or sites where snow loading is an issue.</i>
Switch #5 East Override		OFF Position*	Auto Tracking Enabled
		ON Position	Enable Manual Tracking - East <i>Array will track to the East and stop once the Limit Adjustment Cam engages the limit switch.</i>
Switch #6 West Override		OFF Position*	Auto Tracking Enabled
		ON Position	Enable Manual Tracking - West <i>Array will track to the West and stop once the Limit Adjustment Cam engages the limit switch.</i>
Switch #7 North Override		OFF Position*	Auto Tracking Enabled
		ON Position	Enable Manual Tracking - North <i>Array will track to the North and stop once the Limit Adjustment Cam engages the limit switch.</i>
Switch #8 South Override		OFF Position*	Auto Tracking Enabled
		ON Position	Enable Manual Tracking - South <i>Array will track to the South and stop once the Limit Adjustment Cam engages the limit switch.</i>

15.3 Motor Limits

The limits for your tracker are preset at the factory. Please contact Array Technologies for assistance prior to making any adjustment to the factory settings.



CAUTION

Keep fingers and tools away from the gearing beneath the protective cover of the drive. Failure to do so may result in injury and/or damage to equipment.



WARNING:
PINCH POINT HAZARD



CAUTION

Fully test the tracker range of motion after any adjustment. Perform the full range of motion test at least twice to ensure correct tracker function.

16 Recommended Grounding Instructions



WARNING

ATI strongly recommends allowing only certified electricians to install electrical components in accordance with specifications provided in the installation Assembly Drawings and in accordance with local codes and regulations.



WARNING

Improper installation of electrical or grounding systems could result in serious injury or damage to equipment.

DO NOT USE ANY ATI STRUCTURAL CONNECTIONS AS GROUNDING POINTS.

ATI recommends all grounding and wiring methods be designed and installed in accordance with the National Electrical Code, ANSI/NFPA 70.

16.1 Grounding Modules, Tracker Frame, Drive and Mounting Pipe

The array equipment-grounding conductors for the modules, tracker frame, drive and mounting-pipe must terminate at one location, preferably a grounding terminal strip in the junction/combiner box. A conductor from this point to the grounding electrode (ground rod) is required.

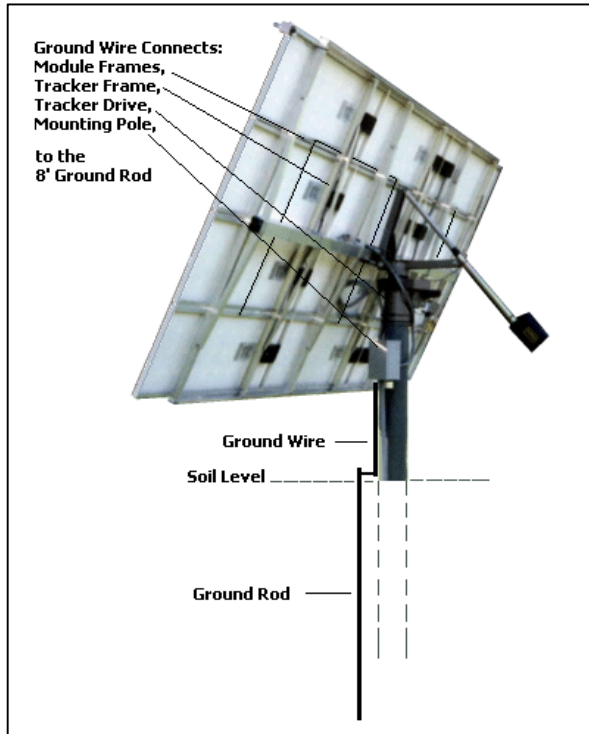

1. The frame of every module is interconnected with grounding wire.
2. The module grounding wire ties into the tracker frame on the torque tube or struts.
3. A flexible loop of grounding wire continues from the torque tube to the base of the drive.
4. The ground wire continues to the mounting pipe or combiner box that is bonded to the pipe.
5. The ground wire goes down the pole and is bonded to an 8-foot copper ground rod.
6. The ground rod is set in the earth outside of the concrete foundation of the pipe.
7. Do not rely on the mounting pipe to act as a ground rod.



CAUTION

Array Technologies, Inc. assumes no liability for electrical installation. Consult the local AHJ or qualified professional for local codes and requirements.

16.2 Ground Tracker to the Battery Bank/Power Center

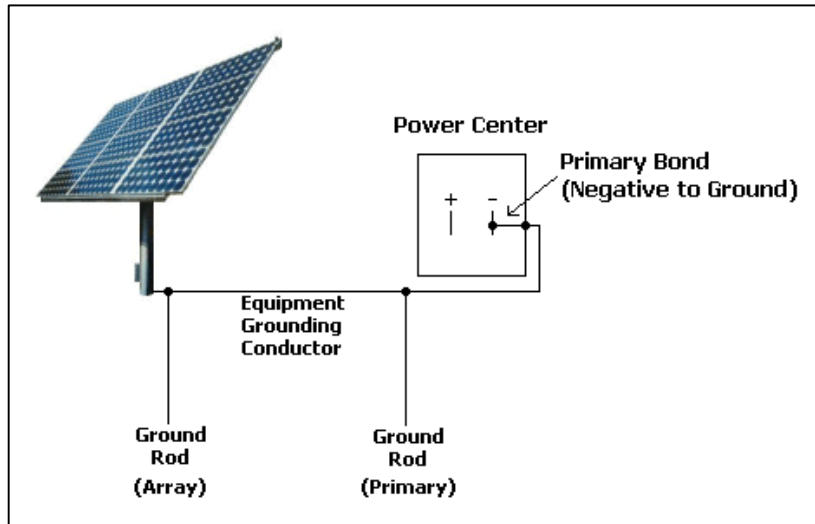

1. The modules, ATI Tracker, and mounting pipe are grounded as shown in Section 16.1.
2. The normal, (primary bond) negative-to-ground bonding is required in the power center or ground-fault device.
3. The negative current-carrying (PV Negative) conductor is bonded (connected) to the grounding system at the power center or charge controller.
4. An equipment-grounding conductor is run from the PV array to the power center or charge controller.

WARNING

Improper installation of electrical or grounding systems could result in serious injury or damage to equipment.

THE PV NEGATIVE MUST BE GROUNDED AT THE POWER CENTER, NOT AT THE ARRAY. THERE MUST BE ONLY ONE GROUND FOR THE CURRENT CARRYING CONDUCTOR.

ATI recommends all grounding and wiring methods be designed and installed in accordance with the National Electrical Code, ANSI/NFPA 70.



CAUTION

Array Technologies, Inc. assumes no liability for electrical installation. Consult the local AHJ or qualified professional for local codes and requirements.



16.3 Alternate Grounding for Tracker Remote from Battery Bank/Power Center

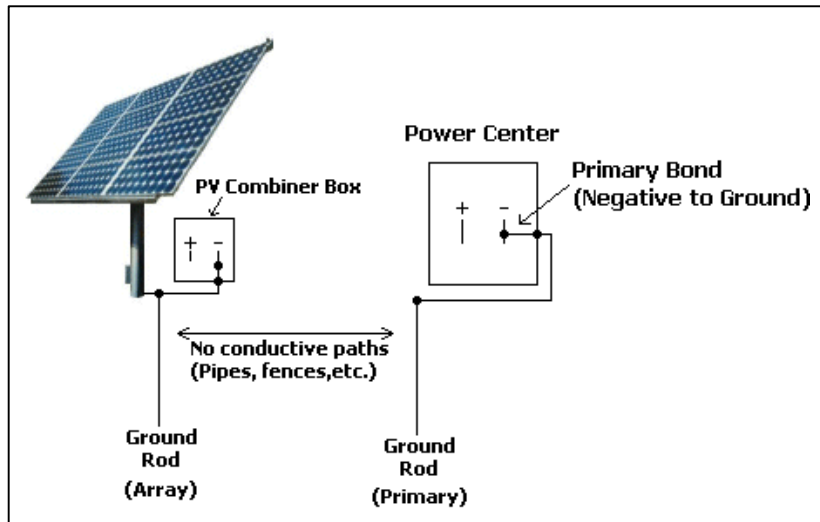

1. The modules, ATI Tracker, and mounting pipe are grounded as shown in Section 16.1.
2. The PV array is ground mounted a distance from other PV components (inverter, batteries, etc.). Additional grounding may be required.
3. There are no AC power circuits between the array and the bank/power center.
4. There are no conductive paths (electrical or other) such as water pipes, metal fences, communication circuits, or telephone circuits between the array and the other structure.
5. Bond the negative conductor (PV Negative) to the grounding system at both the array and at the inverter/battery/power center location.
6. Do not run any equipment grounding conductors between the array and at the inverter/battery/power center location.
7. Use ground rods at the array and at the inverter/battery/power center location.



CAUTION

Array Technologies, Inc. assumes no liability for electrical installation. Consult the local AHJ or qualified professional for local codes and requirements.

Appendix A Additional Tools and Materials Required

The following list includes tools and materials that may be required for proper installation and maintenance. ATI does not provide these materials or tools, but recommends acquiring them as needed.



1	Web Sling Strap	16	25' Measuring Tape
2	PPE – Hard Hat, Glasses, Vest	17	Marker
3	Rubber Mallet	18	100 ft-lb Torque Wrench
4	Cordless Drill	19	3/8" Socket Wrench
5	3/8" Drill Bit	20	1-1/8" Standard Socket
6	Small Cordless Drill	21	1-1/16" Standard Socket
7	T 25 Torque Bit	22	15/16" Standard Socket
8	Pliers	23	3/4" 12-Point Socket
9	Wire Cutters	24	3/8" Combination Wrench
10	Volt Meter	25	7/16" Combination Wrench
11	Banding Snips	26	1/2" Combination Wrench
12	Box Cutter	27	3/4" Combination Wrench
13	P2 Screwdriver	28	15/16" Combination Wrench
14	Flathead Screwdriver	29	1-1/16" Combination Wrench
15	Strap/Rope	30	1-1/8" Combination Wrench

Equipment

- Auger (optional and dependent on support column installation)
- Field grader (optional and dependent on site requirements)
- Forklift or other lifting device
- Ladder or Scaffolding
- Level, laser and standard
- Surveyor's Transit
- Vibratory pile driver (optional and dependent on foundation design)
- Welder, MIG or SMAW
- Wire brush or wire wheel on a grinder (for cleaning welds)

Materials

- Concrete / Rebar (optional and dependent on rack column foundation)
- Gravel (optional and dependent on rack column foundation)
- Additional foundation materials as required by local code and/or foundation engineer
- Paint or cold galvanizing compound, high-solids, zinc-rich (applied to cleaned welds)
- RTV silicone

Appendix B Warranty Terms



ARRAY TECHNOLOGIES, INC.

General Commercial Warranty for Residential Trackers

Array Technologies, Inc. warrants its Residential Solar Trackers to the original consumer purchaser that it will repair, or replace, at Array Technologies Inc.'s option, any Array Technologies component that is determined to be defective in material or workmanship for the following terms:

This warranty shall extend for a period of ten (10) years for all non-driving structural components supplied by Array Technologies, Inc. from the date of purchase by original consumer purchaser. The warranty shall extend for a period of two (2) years for all electrical and drive components such as sensors, controllers, motors, drives, linear actuators and associated wiring from the date of purchase by original consumer purchaser. Replacement parts are warranted for six (6) months or end of product warranty whatever is longer.

We do not warranty the foundation design or installation of the pipe mast or the equipment.

To be eligible for repair or replacement under this warranty, the Service Department of Array Technologies Inc. has to be contacted within the warranty period before sending the part in question to Array Technologies, Inc.

The original consumer purchaser must comply with the following conditions:

- The tracker or component thereof must not have been modified or altered in any way by an unauthorized source.
- The tracker or component thereof must have been installed in accordance with the installation instructions including electrical connections of tracking controller.

This limited warranty does not cover:

- Accidental or intentional damage;
- Corrosion;
- Cosmetic issues;
- Damage due to improper installation of the tracker;
- Misuse, abuse, or neglect;
- Products impaired by severe conditions, such as excessive wind, ice, storms or other natural occurrences;
- Trackers installed at greater heights above grade than specified;
- Trackers installed in environments which exceed design criteria;
- Trackers used for purposes other than the intended use, including mounting modules or components which the tracker was not intended for;
- Trackers with more than the intended number and type of modules mounted on it;
- Damage due to improper packaging on return shipment;
- Miss-alignment of multiple trackers in relation to each other as individual controllers and sensors may vary accuracy;
- Damage due to lightning or power surge.

Any and all labor charges for troubleshooting, removal or replacement of tracker and/or components of the tracker are not covered by this warranty and will **NOT** be honored by Array Technologies, Inc. This is a parts only warranty.

Return shipping is to be pre-paid by the original consumer purchaser.

THIS WARRANTY IS EXPRESSLY IN LIEU OF ALL OTHER WARRANTIES OF ANY KIND, EXPRESSED OR IMPLIED; INCLUDING (WITHOUT LIMITATION) ANY IMPLIED WARRANTIES OF MERCHANTABILITY OR FITNESS FOR A PARTICULAR PURPOSE, AND OF ANY NONCONTRACTUAL LIABILITIES BASED UPON NEGLIGENCE OR STRICT LIABILITY. IN NO EVENT SHALL ARRAY TECHNOLOGIES, INC. BE LIABLE FOR INCIDENTAL OR CONSEQUENTIAL DAMAGES, INCLUDING (WITHOUT LIMITATIONS) ANY DAMAGE FOR PERSONAL INJURY OR PROPERTY DAMAGE OR OTHER PRODUCT LIABILITIES BASED UPON ALLEGED NEGLIGENCE OR BREACH OF EXPRESS OR IMPLIED WARRANTIES OR STRICT LIABILITY. ARRAY TECHNOLOGIES, INC. NEITHER ASSUMES NOR AUTHORIZES ANY OTHER PERSON TO ASSUME FOR IT ANY OTHER OBLIGATION IN CONNECTION WITH THE SALE OF ITS RESIDENTIAL PRODUCTS. THIS LIMITED WARRANTY SHALL NOT EXCEED ORIGINAL PURCHASE PRICE OF THE PRODUCT.

Array Technologies, Inc.
3901 Midway PI NE
Albuquerque, NM 87109

Tel: 505-881-7567
Fax: 505-881-7572
www.arraytechinc.com

90028-000 Rev. A

General Commercial Warranty for ATI Residential Trackers

Page 1 of 1

Warranty Information Card

DuraTrack™ DA Dual Axis Tracker

Serial Numbers:

Controller Serial Number: _____

Drive Assembly Serial Number: _____

Power Source: Battery Bank Power Supply

System Type: Off Grid/Remote Grid-Tied, no battery

Grid-Tied with battery Water Pumping

Other _____

PV Array:

PV System Voltage _____ VDC

Number of Modules: _____

Module Manufacturer: _____

Module Model : _____

Mounting Pole Height: _____ FT

Appendix C Recommended Maintenance

- ◆ Periodically check modules for build-up of dirt or debris. Clean as necessary to maximize power output.
- ◆ Maintenance should be performed at least once a year; more often if your tracker is installed in severe weather areas.
- ◆ Inspect all the tracker hardware and the module bolts for tightness. Tighten all nuts and bolts that have loosened or do not meet torque spec.
- ◆ Inspect all wires for abrasion and gently tug on them to make sure that they are secure.
- ◆ Lubricate the drive motor. Each of the four grease zerks should receive 4-6 pumps of lithium-base general-purpose chassis grease from a grease gun.
- ◆ Spray the inner tube (telescoping part) of the linear actuator with a lubricating rust inhibitor. (ATI recommends LPS-3)

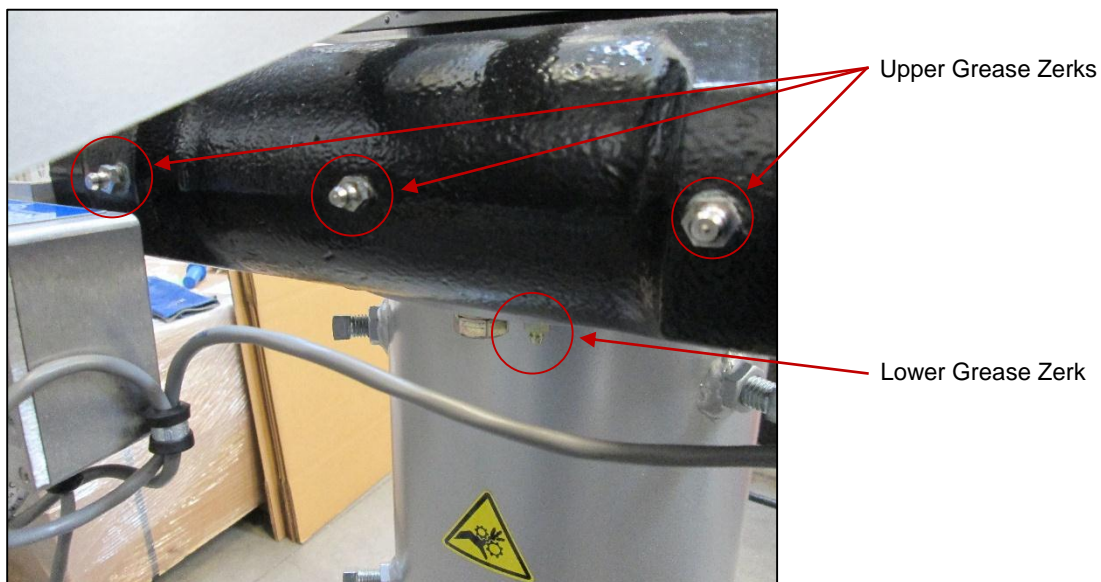

Please contact ATI Service for questions or concerns:

Phone: (505) 944-7694

ServiceDesk@arraytechinc.com

LPS® LPS 3®

PREMIER RUST INHIBITOR



Qualified to: BMS 3-23 G Type II, TN
A.007.10138 Type I Grade 2
DMS 2150, Lockheed G39.2004
Conforms to: Mil-PRF-16173E Grade 2
ASTM F-945, PWA 36604

PACKAGES

Net Contents	Part No.
11 wt.oz. / 312 g/ 380 ml aerosol	00316
1 gal. (3.78 liters)	03128
5 gal. (18.93 liters)	00305
55 gal. (208 liters)	00355
20 fl.oz (591 ml) trigger spray	00322

APPLICATIONS

- Aircraft Fuselages
- Battery Terminals
- Cables, Chains, & Pulleys
- Cargo Sections
- Elevators
- Metal Parts
- Offshore Drilling Equipment
- Outdoor Electrical Connections
- Outdoor Equipment & Tools
- Overseas Storage or Shipments
- Pumps & Hose Assemblies
- Interior Sections of Vehicle Doors



Nonfood Compounds Program Listed
Category Code: H2 Registration
#129027 Aerosol, #059649 Bulk

PROPERTIES



Appearance/Physical State:
Opaque brown liquid

Dielectric Strength (ASTM D-877):
19.5 kv

Flash Point (TCC)
< 70°F (21°C) (aerosol)
100°F (40°C) minimum (bulk)

HMS: 1, 2, 0

Humidity Cabinet Test (ASTM D
1748): No rust on 1029 steel panels
after 30 days

Pour Point: 0°F (- 18°C)

Propellant: Carbon Dioxide

Salt Spray Cabinet Test (ASTM B117):
No corrosion on 2024-T3 alumi-
num panels after 1500 hours

Specific Gravity (water=1):
0.82 – 0.86

Typical Dried Film Thickness:
50 – 100 microns (2 - 4 mils)

Viscosity at 25°C: 200 – 600 cps

MATERIAL SAFETY DATA SHEETS AVAILABLE UPON REQUEST OR VISIT OUR WEB SITE :WWW.LPSLABS.COM

LPS Laboratories • An Illinois Tool Works Company

4647 Hugh Howell Road • Tucker, GA 30084 • TEL: (800) 241-8334 or (770) 243-8800 • FAX: (800) 543-1563 or (770) 243-8899

Internet Web Site: www.lpslabs.com

©2012 LPS Laboratories • LPS® is a registered trademark of Illinois Tool Works • Printed in U.S.A. • All Rights Reserved • Form #2015- Rev. 5/2012

Mobilith SHC Series

Grease

Product Description

Mobilith SHC Series greases are supreme performance products designed for a wide variety of applications at extremes of temperature. They combine the unique features of synthetic base fluids with those of a high quality lithium complex thickener. The wax-free nature of synthetic fluids and the low coefficient of traction (compared with mineral oils), provide excellent low temperature pumpability and very low starting and running torque. These products offer the potential for energy savings and can reduce operating temperatures in the load zone of spherical roller and ball bearings. The lithium complex thickener contributes excellent adhesion, structural stability and resistance to water. The greases have a high level of chemical stability and are formulated with special additive combinations to provide excellent protection against wear, rust and corrosion at high and low temperatures. Mobilith SHC Series greases are available in seven grades, varying in base oil viscosity from ISO VG 100 to 1500 and in NLGI grade from 2 to 00.

Mobilith SHC Series greases have become the products of choice for many users, in many industries worldwide. Their reputation is based on their exceptional quality, reliability, versatility and the performance benefits they deliver.

Features and Benefits

The Mobil SHC brand of oils and greases are recognized and appreciated around the world for their innovation and outstanding performance. The Mobilith SHC series symbolizes ExxonMobil's continued commitment to using advanced technology to provide outstanding products. A key factor in the development of the Mobilith SHC Series were the close contacts between our scientists and application specialists with key Original Equipment Manufacturers (OEMs) to ensure that our product offerings would provide exceptional performance in the continually evolving industrial equipment designs. Our work with equipment builders has helped confirm the results from our own laboratory tests showing the exceptional performance of the Mobilith SHC Series lubricants. These benefits include longer grease life, enhanced bearing protection and bearing life, wide temperature range of application, and the potential for improved mechanical efficiency and energy savings. To combat high thermal exposure of the oil our product formulation scientists chose proprietary synthetic base oils for Mobilith SHC Series oils because of their exceptional thermal/oxidative resistance potential. Our scientists developed a state-of-the-art lithium complex thickener technology and used specific additives to enhance the performance of each grade of the Mobilith SHC Series product family. The Mobilith SHC Series greases offer the following features and benefits:

Features	Advantages and Potential Benefits
Outstanding high temperature and low temperature performance	Wide application temperature ranges, with excellent protection at high temperatures and low torque, easy start-up at low temperatures
Excellent protection against wear, rust and corrosion	Reduced downtime and maintenance costs because of reduced wear, rust and corrosion
Excellent thermal stability and oxidation resistance	Extended service life with longer intervals between relubrication and improved bearing life

Features	Advantages and Potential Benefits
Low traction coefficient	Potential improved mechanical life and reduced energy consumption
Includes both high and low viscosity grades	Options for outstanding protection of slow speed, heavily loaded bearings, and options for good low temperature performance
Outstanding structural stability in the presence of water	Retains excellent grease performance in hostile aqueous environments
Low volatility	Helps resist viscosity increase at high temperatures to maximize relubrication intervals and bearing life

Applications

Application Considerations: While Mobilith SHC Series greases are compatible with most mineral oil based products, admixture may detract from their performance. Consequently it is recommended that before changing a system to one of the Mobilith SHC Series, it should be thoroughly cleaned out to achieve the maximum performance benefits. While the Mobilith SHC Series greases share many performance benefits, their applications are best described in terms of each product grade:

- Mobilith SHC 100 is an antiwear and extreme pressure grease primarily recommended for higher speed applications such as electric motors, where reduced friction, low wear and long service life are required. It is an NLGI 2 Grade / ISO VG 100 grease with a synthetic base fluid. Its operating temperature range is -40° C* to 150° C.
- Mobilith SHC 220 is a multi-purpose, NLGI 2 extreme pressure grease recommended for heavy-duty automotive and industrial applications. It uses an ISO VG 220 synthetic base fluid. Mobilith SHC 220 has a recommended operating temperature range of -40° C* to 150° C.
- Mobilith SHC 221 is a multi-purpose, extreme pressure grease recommended for heavy-duty automotive and industrial applications, particularly where centralized grease systems are utilized. It uses an ISO VG 220 synthetic base fluid. Mobilith SHC 221 has a recommended operating temperature range of -40° C to 150° C.
- Mobilith SHC 460 is an NLGI 1.5 Grade grease with ISO VG 460 synthetic base fluid and is an extreme pressure grease recommended for tough industrial and marine applications. It provides outstanding bearing protection under heavy loads at low-to-moderate speeds and in applications where water resistance is a critical factor. Mobilith SHC 460 has demonstrated outstanding performance in steel mills, paper mills and marine applications. The recommended operating temperature range is -30° C* to 150° C.
- Mobilith SHC 1000 Special is an NLGI 2 Grade grease with ISO VG 1000 synthetic base fluid and strongly fortified with solid lubricants including 11% graphite and 1% molybdenum disulphide for maximum protection of plain or rolling element bearings operating under boundary lubrication regimes. This product is designed to extend bearing life under conditions of extremely slow speeds, heavy loads and high temperatures. Mobilith SHC 1000 Special has a recommended operating temperature of -20° C* to 150 °C with appropriate relubrication intervals.
- Mobilith SHC 1500 is an NLGI 1.5 Grade / ISO VG 1500 grease with a synthetic base fluid. It is intended for use in plain and rolling element bearings operating at extremely slow speeds, under heavy loads and high temperatures. Mobilith SHC 1500 has a recommended operating temperature range of -20 °C* to 150 °C with appropriate relubrication intervals. Continuous lubrication with Mobilith SHC 1500 has been very effective in prolonging bearing life in a severe roll press application. Mobilith SHC 1500 has also provided excellent performance in rotary kiln roller bearings and in slag transfer rail car bearings.
- Mobilith SHC 007 is an NLGI 00 Grade / ISO VG 460 grease with a synthetic base fluid; it has a recommended operating temperature range of -50° C to 150 ° C with appropriate relubrication intervals. Its primary uses are in grease filled industrial gear cases subject to high temperatures, where conventional

semi fluid greases will not provide acceptable lubricant life and in non-driven heavy-duty truck trailer wheel hubs.

*Low temperature claims based on ASTM D 1478 results vs. maximum limits of 10,000 / 1000 gcm @ startup and 1 hour respectively.

Specifications and Approvals

Mobilith SHC Series meets the following industry specification:	100	220	221	460	1000 Special	1500	007
AAR M-942-98	X	-	X	-	-	-	-
DIN 51825	KPHC 2N-40	KPHC 2N-40	-	KPHC 1-2N-40	KPFHC 2N-30	KPHC 1-2N-30	-
DIN 51826	-	-	-	-	-	-	GPHC 00K-30

Typical Properties

Mobilith SHC Series	100	220	221	460	1000 Special	1500	007
NLGI Grade	2	2	1	1.5	2	1.5	00
Thickener Type	Lithium Complex	Lithium Complex	Lithium Complex	Lithium Complex	Lithium Complex	Lithium Complex	Lithium Complex
Color, Visual	Red	Red	Light Tan	Red	Grey Black	Red	Red
Penetration, Worked, 25°C, ASTM D 217	280	280	325	305	280	305	415
Dropping Point, °C, ASTM D 2265	265	265	265	265	265	265	-
Viscosity of Oil, ASTM D 445 cSt @ 40°C	100	220	220	460	1000	1500	460
Timken OK Load, ASTM D 2509, kg (lb).	29.5 (65)	29.5 (65)	29.5 (65)	29.5 (65)	29.5 (65)	29.5 (65)	29.5 (65)
4-Ball Weld, ASTM D 2596, Load, Kg	250	250	250	250	620	250	250
Water Washout, ASTM D 1264, 79 °C, % Wt. Loss	6	3	4	3	2.6	2.5	-
Rust Protection, ASTM D 6138, Distilled Water	0,0	0,0	0,0	0,0	0,0	0,0	-
Corrosion Protection, ASTM D 1743, Rating	Pass	Pass	Pass	Pass	Pass	Pass	-
4-Ball Wear, ASTM D 2266, Scar, mm	0.50	0.50	0.50	0.50	0.50	0.50	0.50
Low Temperature Torque, ASTM D 1478, Torque @ Startup/1 Hour in gcm and Test T°	9520/2199 @ -50 °C	4361/836 @ -40 °C	----	9060/2944 @ -40 °C	----	1874/1000 @ -20 °C	----
U.S. Mobility, AM-S 1390, -18 °C, gms/min	20.0	11.0	----	5.0	----	3.0	----

Health and Safety

Based on available information, this product is not expected to produce adverse effects on health when used for the intended application and the recommendations provided in the Material Safety Data Sheet (MSDS) are followed. MSDS's are available upon request through your sales contract office, or via the Internet. This product should not be used for purposes other than its intended use. If disposing of used product, take care to protect the environment.

The Mobil logotype, the Pegasus design and Mobilith SHC are trademarks of Exxon Mobil Corporation, or one of its subsidiaries..

idec 120W & 240W PS5R Slim Line Power Supplies

- Features**
- Compact size:
120W - only 50mm width
240W - only 80mm width
 - Universal AC input (85 to 265V AC)
 - DC input (84 to 350V DC)
 - Power factor correction (EN61000-3-2)
 - Meet SEMI F47 Sag Immunity
 - Class 1, Div 2 Hazardous Locations
 - DC ON LED indicator & DC low LED indicator
 - Overcurrent protection, auto reset
 - Overvoltage protection, shut down
 - Adjustable output voltage ($\pm 10\%$)
 - Screw terminal type, IP20
 - Surface mount or DIN rail mount
 - Additional Approvals: EMI: EN61204-3 (class B)
EMS: EN61204-3 (industrial), UL508,
IEC/EN60950, UL1604, TUV, UL Listing, c-UL



IDEC's PS5R Slim Line of power supplies gives you all the power of a traditional power supply in only half the space. The 120W unit has a width of only 50mm while the 240W is just 80mm wide. They also come with all the convenient features you've come to expect from IDEC's top-selling power supplies.



Specifications

		120 W	240W	
		PS5R-SF24	PS5R-SG24	
Input	Input voltage	85 to 264V AC, 100-350V DC		
	Input Current	100VAC 200VAC	1.8A max 1.0A max	3.5A max 1.7A max
	Internal Fuse Rating	250V, 4A		
	Inrush Current 200VAC	50A max		
	Leakage Current	1mA max		
	Typical Efficiency 24V DC	84%		
Output	Output Current Ratings at 24V DC	5A		10A
	Voltage Adjustment	$\pm 10\%$ (V. ADJ control on front)		
	Output Holding Time	20msec min (at rated input and output)		
	Starting Time	650msec max		
	Rise time	200msec max (at rated input and output)		
	Line Regulation	0.4% max		
	Load Regulation	1.5% max		
	Temperature Regulation	0.05% °C max		
	Ripple voltage	1% p-p max including noise		
	Overcurrent Protection	105-130%, auto reset		
Overvoltage Protection	120% or more, shutdown			

Specifications con't on following page

Specifications con't

	120W	240W	
	PS5R-SF24	PS5R-SG24	
General Specifications	Dielectric Strength	Between input and ground: 2000V AC, 1 minute	Between input and ground: 2000V AC, 1 minute
	Insulation Resistance	Between input and output terminals: 100M Ω min	Between input and output terminals: 100M Ω min
	Operating Temperature	-10 to +60°C (14 to 140°F)	-10 to +60°C (14 to 140°F)
	Storage Temperature	-25 to +75°C (-13 to 167°F)	-25 to +75°C (-13 to 167°F)
	Operating Humidity	20 to 90% relative humidity (no condensation, no freezing)	20 to 90% relative humidity (no condensation, no freezing)
	Vibration Resistance	Frequency 10 to 55Hz, Amplitude 0.375mm, 2 hours each in 3 axes	Frequency 10 to 55Hz, Amplitude 0.375mm, 2 hours each in 3 axes
	Shock Resistance	300m/s ² 3 times each in 6 axes (150m/s ² using mounting bracket)	300m/s ² 3 times each in 6 axes (150m/s ² using mounting bracket)
	Approvals	SEMI F47 UL: UL508 (Listing), UL1604 c-UL: CSA C22.2 No. 14 TUV: EN60950, EN50178 EMI: EN61204-3 (Class B) EMS: EN61204-3 (Industrial)	SEMI F47 UL: UL508 (Listing), UL1604 c-UL: CSA C22.2 No. 14 TUV: EN60950, EN50178 EMI: EN61204-3 (Class B) EMS: EN61204-3 (Industrial)
	Harmonic Directive	EN61000-3-2 A14 Class A	EN61000-3-2 A14 Class A
	Weight (Approx)	630g	1000g
	Terminal Screw	M3.5 slotted-Philips head screw (screw terminal type)	M3.5 slotted-Philips head screw (screw terminal type)
	IP Protection	IP 20 (finger-safe)	IP 20 (finger-safe)
	Direct Panel Mounting Bracket	PS9Z-5R1G	PS9Z-5R1G
	Dimensions HxWxD mm	115 x 50 x 129	125 x 80 x 149.5
Dimensions HxWxD inches	4.53 x 1.97 x 5.08	4.92 x 3.15 x 5.89	

PS5R-SF (120W)

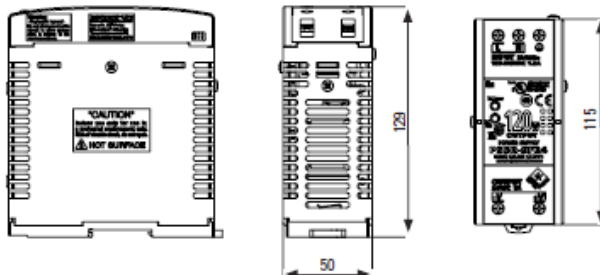

PS5R-SG (240W)

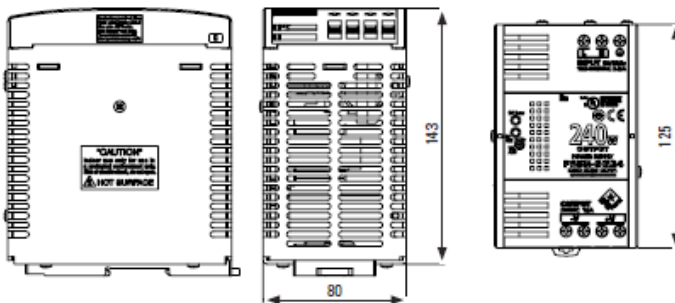

(dimensions are in mm)



For more information on the PS5R Slim Line series of power supplies visit

www.idec.com/usa/powersupply

For more information call IDEC at:
800-262-IDEAC (4332)
1175 Elko Drive • Sunnyvale, CA 94089
Fax: 408-745-5258 • www.idec.com

©2004 IDEC Corporation. All Rights Reserved.
Part #PS9Y-DS100-0 10/04

IDEC PS5R-SF24 POWER SUPPLY

FUNCTION:

To supply 24 VDC to an ATI Solar Tracker in a grid-tie application where there is AC power available.

LOCATION:

The IDEC power supply could be located in the main equipment room or mounted on the tracker pipe mast. It must be enclosed in a Raintight NEMA enclosure if it is mounted outside.

GROUNDING:

The negative 24 VDC output of the power supply should not be "floated." It should be grounded to the tracker frame and equipment grounding buss located at the mounting pole. Any "noise" on the power feed to the tracker controller will be eliminated by this grounding method.

AC INPUT
100-240 VAC @ 1.8 AMPS



DC OUTPUT
24 VDC @ 5 AMPS

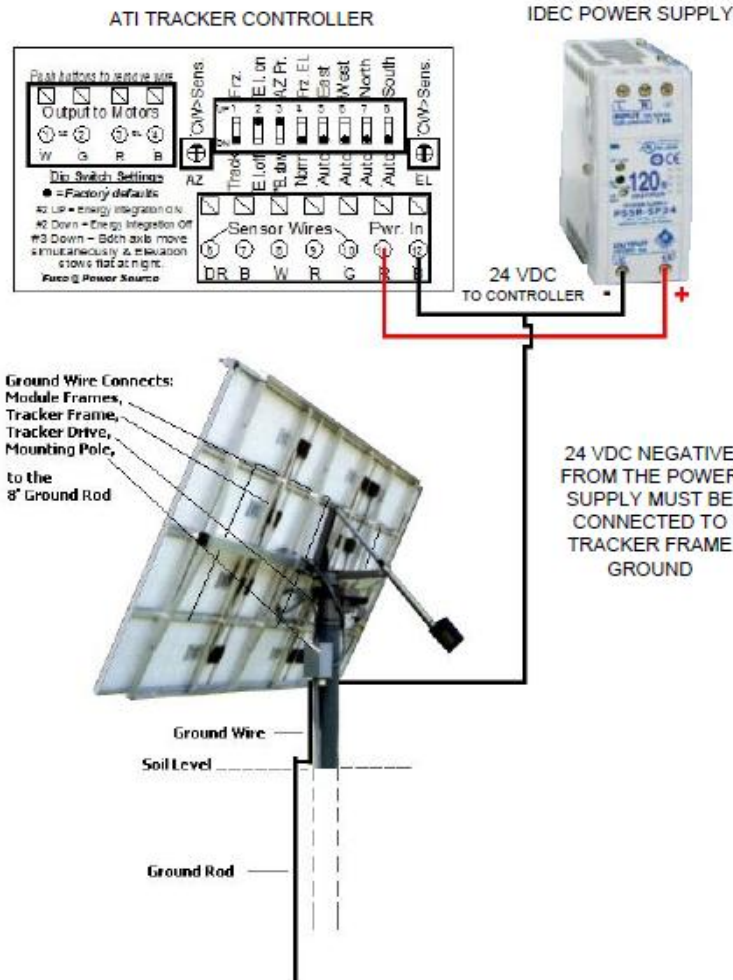



MEAN WELL
SWITCHING POWER SUPPLY
ISO-9001 CERTIFIED MANUFACTURER

DR-45
SERIES

- LOW COST, HIGH RELIABILITY
- .105°C OUTPUT CAPACITOR
- INTERNATIONAL AC INPUT RANGE
- HIGH EFFICIENCY, LOW WORKING TEMPERATURE
- .SOFT-START CIRCUIT, LIMITING AC SURGE CURRENT
- .SHORT CIRCUIT, OVERLOAD, OVER VOLTAGE PROTECTED
- .COMPACT SIZE, LIGHT WEIGHT
- .100% FULL LOAD BURN-IN TEST
- .BUILT IN EMI FILTER, LOW RIPPLE NOISE



MODEL	DR-4505	DR-4512	DR-4515	DR-4524
SPECIFICATION				
DC OUTPUT VOLTAGE	5V	12V	15V	24V
OUTPUT V. TOLERANCE	±2%	±1%	±1%	±1%
OUTPUT RATED CURRENT	5A	3.5A	2.8A	2A
OUTPUT CURRENT RANGE	0-5A	0-3.5A	0-2.8A	0-2A
RIPPLE & NOISE	100mVp-p	200mVp-p	240mVp-p	480mVp-p
LINE REGULATION	±1%	±1%	±1%	±1%
LOAD REGULATION	±1%	±1%	±1%	±1%
DC OUTPUT POWER	25W	42W	42W	48W
EFFICIENCY	72%	77%	77%	80%
DC VOLTAGE ADJ.	+10, -5%	±10%		
INPUT VOLTAGE RANGE	85~264VAC 47~63Hz, 120~370VDC			
AC CURRENT	1.5A/115V 0.75A/230V			
INRUSH CURRENT	COLD START 30A/115V 60A/230V			
LEAKAGE CURRENT	<1mA/240VAC			
OVERLOAD PROTECTION	105% ~150% TYPE:CONSTANT CURRENT LIMITING RESET:AUTO RECOVERY			
OVER VOLTAGE PROTECTION	115% ~135%			
OVER TEMP. PROTECTION	Tj 135°C TYPICALLY POWER SHUTDOWN			
TEMP. COEFFICIENT	±0.03% / °C (0~50° C)			
SETUP, RISE, HOLD UP TIME	800ms;60ms; 50ms/230V			
VIBRATION	10~500Hz, 2G 10min./1cycle, PERIOD FOR 60min. EACH AXES			
WITHSTAND VOLTAGE	I/P-O/P:3KVAC I/P-FG:1.5KVAC O/P-FG:0.5KVAC			
ISOLATION RESISTANCE	I/P-O/P, I/P-FG, O/P-FG:500VDC / 100M Ohms			
WORKING TEMP., HUMIDITY	-10° C~+50° C(REFER TO OUTPUT DERATING CURVE), 20%~90% RH			
STORAGE TEMP., HUMIDITY	-20° C~+85° C, 10%~95% RH			
DIMENSION	93*78*67mm			
WEIGHT	0.4Kgs			
SAFETY STANDARDS	TUV EN60950, UL508 APPROVED			
EMC STANDARDS	CISPR22 (EN55022) CLASS B, EN61000-4-2,3,4,5,6,8,11; ENV50204, EN61000-3-2,-3, EN50082-2			
NOTE :	1. ALL PARAMETERS ARE SPECIFIED AT 230VAC INPUT, RATED LOAD, 25°C 70% RH AMBIENT. 2. TOLERANCE : INCLUDE SETUP TOLERANCE, LINE REGULATION, LOAD REGULATION. 3. RIPPLE & NOISE ARE MEASURED AT 20MHz BY USING A 12" TWISTED PAIR TERMINATED WITH A 0.1µF & 47µF CAPACITOR. 4. LINE REGULATION IS MEASURED FROM LOW LINE TO HIGH LINE AT RATED LOAD. 5. LOAD REGULATION IS MEASURED FROM 0% TO 100% RATED LOAD.			

2002-08-11

Appendix D Troubleshooting

Troubleshooting Azimuth Trackers V#3 Controller

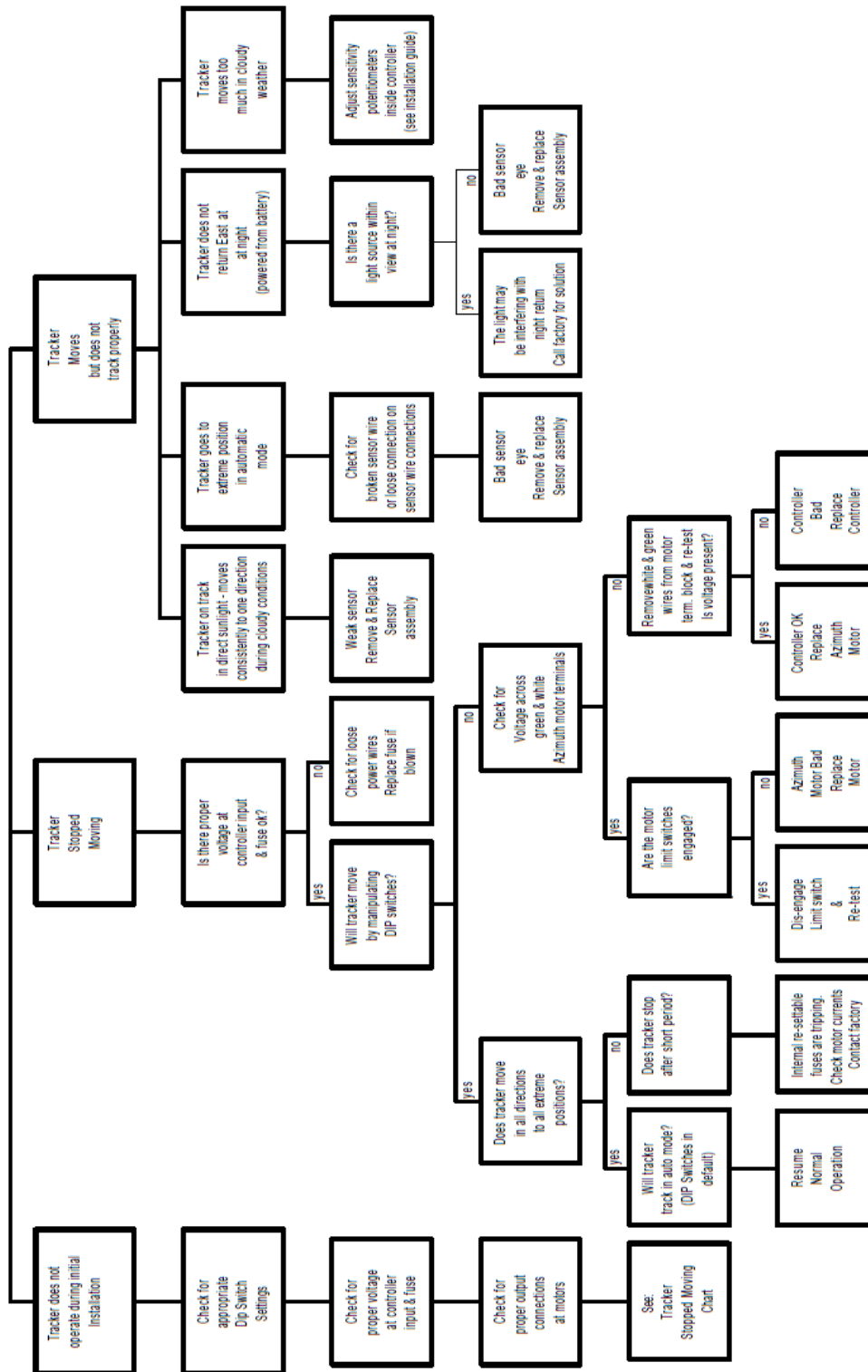

PROBLEM	SOLUTION
For problems arising during initial installation	<ul style="list-style-type: none"> • Check for appropriate dip switch settings in accordance with installation parameters
Tracker stopped moving	<ul style="list-style-type: none"> • Test for voltage at controller input. • Test for blown 5 Amp fuse in controller. • Test for voltage at controller azimuth output (green & white wires).
No voltage at controller input	<ul style="list-style-type: none"> • Check for loose wire connection. • Check for blown supplemental fuse if one is installed.
Fuse blown in controller	<ul style="list-style-type: none"> • Check for tracker binding on service loop or obstruction. Replace 5 amp fuse and test. • Check for continuity to ground from azimuth and elevation wire terminals (Green, White, Red & Black) • They should read no continuity. • Replace main electronic board.
No output at green and white azimuth wires	<ul style="list-style-type: none"> • Remove green and white wires from motor terminal strip and test voltage when disconnected. No voltage = replace control box
Voltage at green and white azimuth output wires when disconnected from motor	<ul style="list-style-type: none"> • Test azimuth motor. Apply DC (12-24 vdc) voltage to terminals 1 & 2 on motor. (CONTROLLER WHITE AND GREEN WIRES MUST BE DISCONNECTED FROM MOTOR) Damage will result if controller output wires are connected to a voltage source. If motor runs check current draw. Current draw maximum on AZ motor is 750 ma.
Tracker tracks for a moment and then stops for the rest of the day	<ul style="list-style-type: none"> • Internal self-resetting fuse is blown. • Disconnect power to the controller to reset the fuse. Test tracker using internal dip switches. Measure current draw of Azimuth Motor (should not exceed 750 ma) • Check for tracker binding on service loop or obstruction.
Tracker tracked normally in all directions but stopped at East or West limit position.	<ul style="list-style-type: none"> • Tracker limit switch cams set too far and tracker hit welded stops. - Reset limit switches and re-cycle input power. • Check for sticky limit switch.
Tracker "ran by" limit switch beyond normal East or West limit position and stopped at the welded stop.	<ul style="list-style-type: none"> • Test for short to ground in motor. • Check continuity between each Azimuth motor power terminal and ground on the pole. • Replace motor.
Tracker does not stay on track in direct sunlight; wanders in one direction during cloudy conditions - operates with dip switches.	<ul style="list-style-type: none"> • Replace optical sensor
Tracker does not return East at night (Battery powered only)	<ul style="list-style-type: none"> • Check for power input at night • Illumination on sensor at night • Replace optical sensor

Tracker returns East in late morning early afternoon (PV powered only)	<ul style="list-style-type: none">• Tracker moving too far to the West.• Check for true South orientation of drive and make sure West limit stops tracker 10 degree before due West.
Tracker oscillates E/W or N/S	<ul style="list-style-type: none">• Water in optical sensor chassis• Water in controller chassis

Appendix E Revision History

Release Date	Revision Letter	Description of Change
01/15/2014	ORIGINAL	Original release.

Index

alert messages		
caution	3	
danger	3	
note or tip	3	
warning	3	
Assembly Drawing Package (ADP)	12	
grounding		
panel wiring	40	
grounding lugs	40	
hazards		
high voltage	10	
symbols	4	
lockout and tagout		
devices	10	
overview	10	
materials handling		
disassembly	15	
lifting and moving	14	
receiving	13	
spare parts	15	
storage	14	
transportation	13	
materials required		
additional	A-2	
panel wiring	40	
pile tolerances	17	
protective gear	8	
safety		
equipment	8	
procedures	8	
site		
evaluation	11	
preparation	12	
structural and mechanical features	7	
support columns	16, 17	
installation	17	
tools required		
additional	A-2	
torqueing bolts procedures	18	