

ZONE	REV	DESCRIPTION	DATE	BY	CHKD	APP'D	DATE
	-	RELEASED 80844 FOR PRODUCTION	7453	BCP	MAH		01/15/13
	A	CORRECTED BOM	7468	BCP	MAH		04/18/13

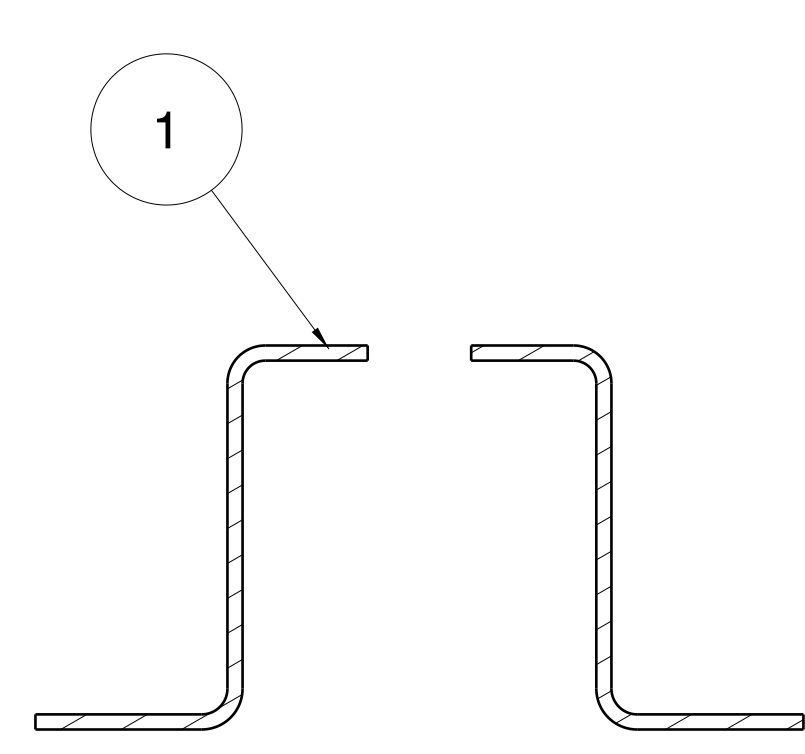

SECTION A-A  
SCALE: 2:1

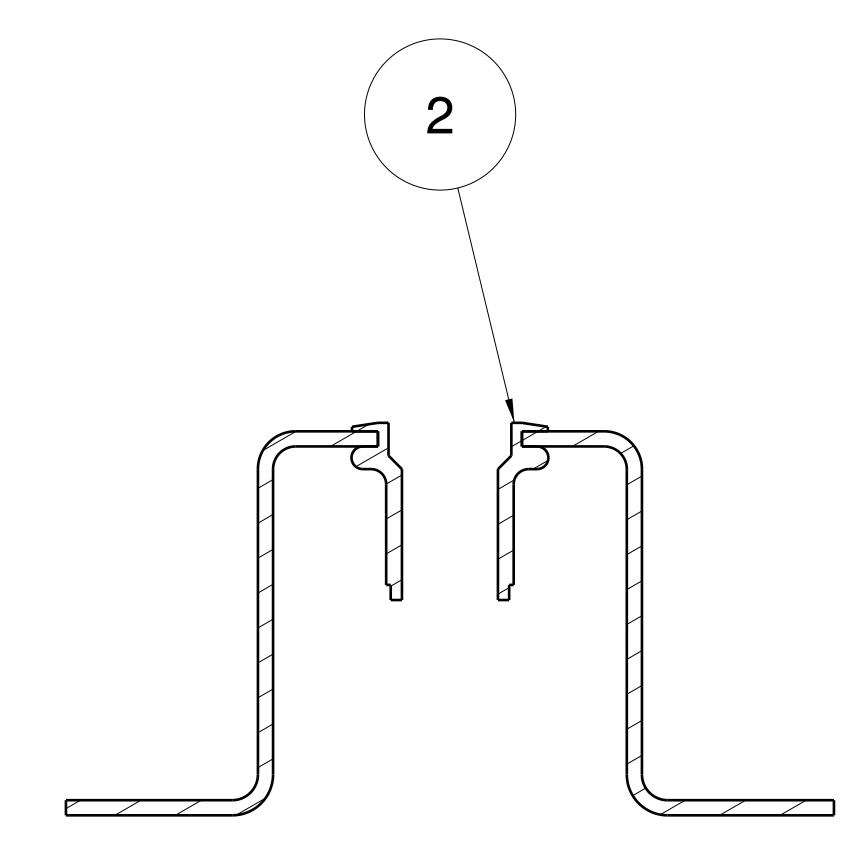

SECTION B-B  
SCALE: 2:1

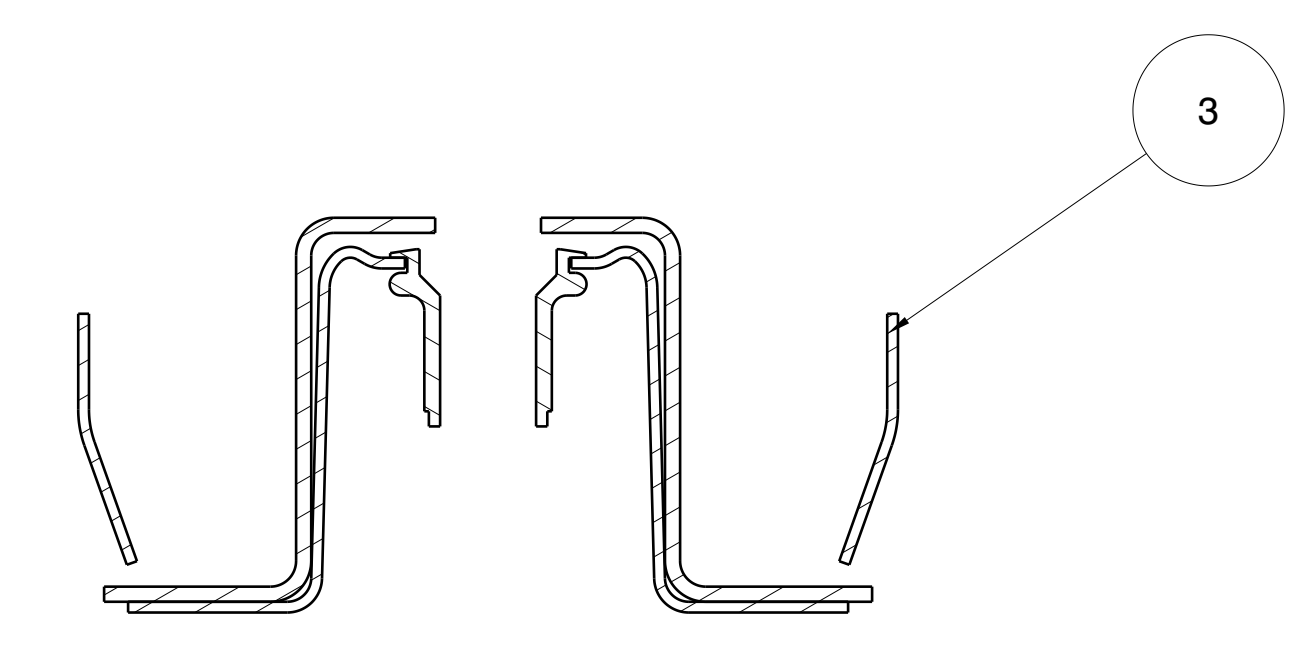

SECTION C-C  
SCALE: 2:1

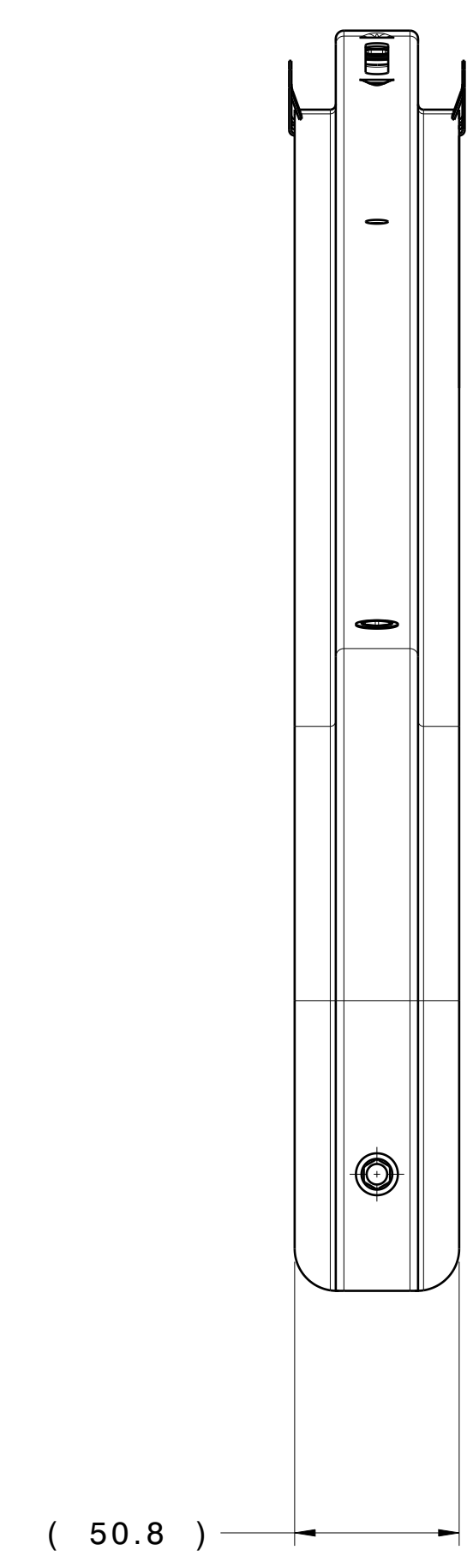
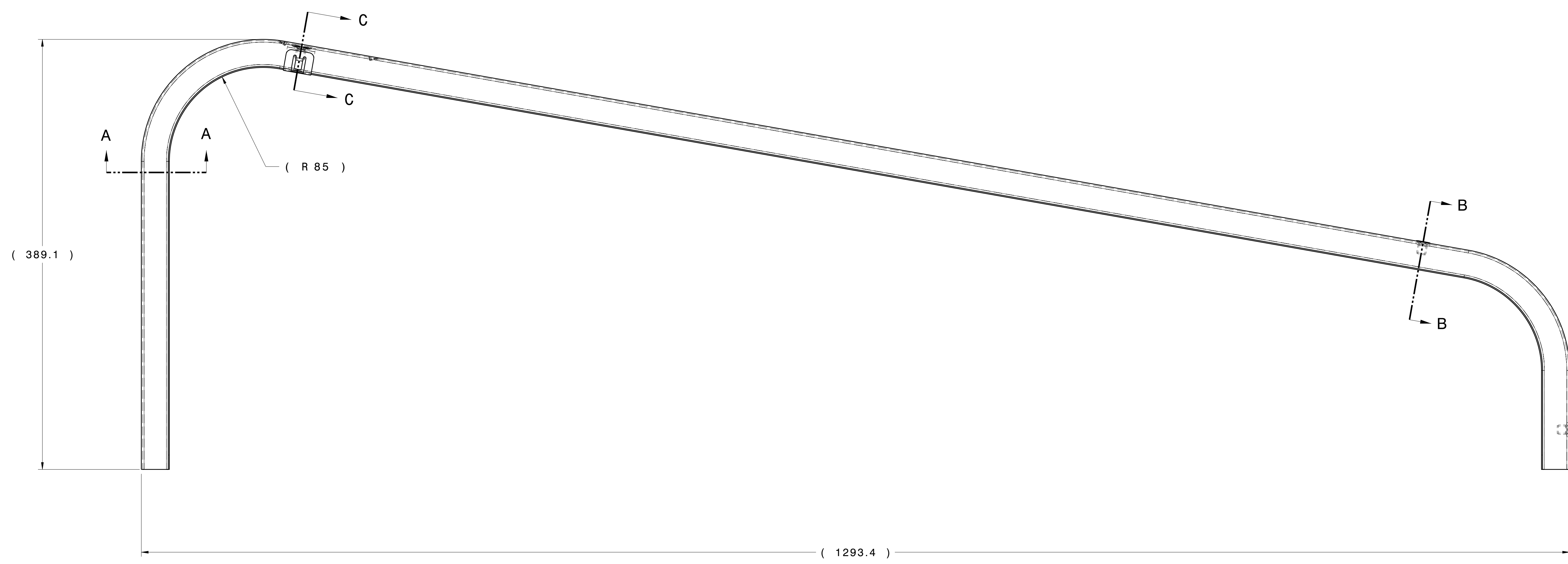
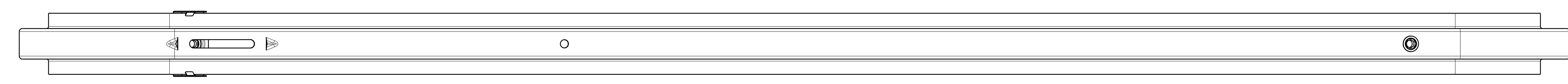
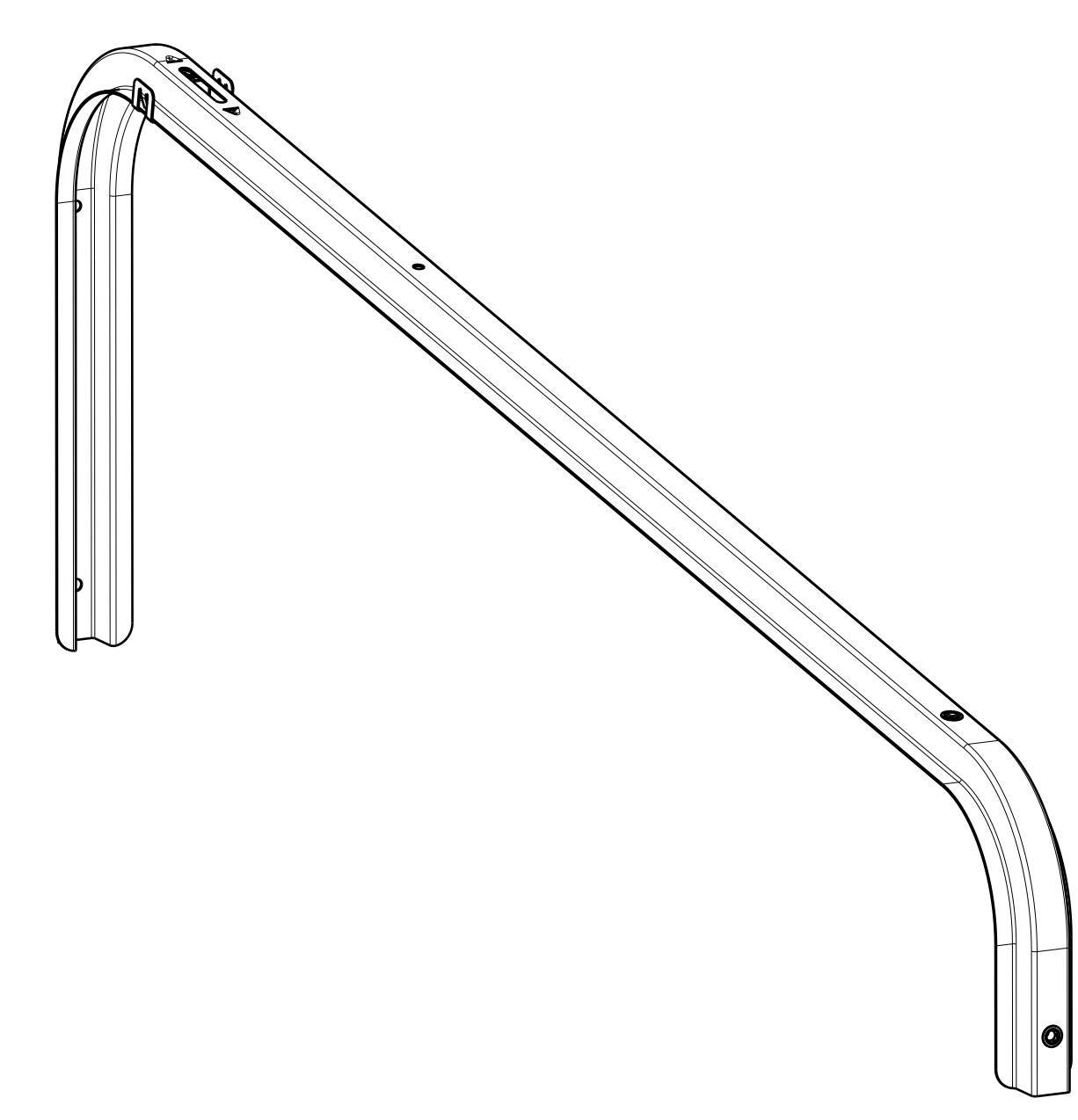

( 50.8 )

QTY	REV	PART NO.	DESCRIPTION
1	3	80025	RETAINER ASM - SLIDE NUT
2	2	80007	RIVET NUT - 1/4- 20 HEX
1	1	80843	SUPT RL PRG ADJ - 10 DEG 953- 1001 MDL

DESCRIPTION	DO NOT SCALE - REPORT ALL ERRORS UNLESS OTHERWISE SPECIFIED
51 INCH ROW SPACING	UNLESS OTHERWISE SPECIFIED ALL DIMENSIONS ARE IN INCHES (MILLIMETERS)
UNSPECIFIED TOLERANCES:	SEE
DECIMAL	IN
F. & D.	± .02
DEC	± .01
ANGULAR	± .05

DATE	BY	DATE	BY
01/15/13	BCP	01/15/13	MAH
01/15/13	JHH	01/15/13	JHH

DESCRIPTION	SCALE	PART NO.	REV
SUPT RL ASM 10 DEG ADJ 953- 1001 MDL	1:2	80844	A
		C80844	

- NOTES: UNLESS OTHERWISE SPECIFIED
1. RIVET NUT TO BE SECURELY STAKED TO THE RAIL (2 PLACES)
  2. RAIL TO BE FREE OF BURRS AND SHARP EDGES
  3. MINIMUM RIVET NUT SPINOUT 60 LBS.

