

ABB solar system accessories

Rapid Shutdown for residential and small commercial



ABB now offers the only family of rapid shutdown products for string inverters today. This product provides a fail-safe solution for emergency responders to eliminate voltage at the PV array in compliance with NEC 2014 Rapid Shutdown code requirements.

The ABB Rapid Shutdown system requires no extra conduit; minimizing additional material cost and associated labor.

Shutdown occurs at the rooftop box when utility power is lost or when the PV system's AC disconnect switch is opened. In jurisdictions requiring a dedicated activation switch, an optional emergency stop button is available. The Rapid Shutdown box can mount directly to the PV mounting rail and lay parallel to the roofing surface. The NEMA 4X design permits installation angles from 0-90° while maintaining its water-tight seal from mounted snow or driven rain.

Three models are available to cover all system configurations; including, a two-string pass through, a two-string combined and a four-string combined box.

The unique features of each box can be used to maintain the specific configuration of the PV system. Dual outputs in the box maintain the benefits of ABB's dual MPPT inverter channels, while the single output box is perfect for small PV arrays utilizing one MPPT channel or systems requiring two rapid shutdown boxes.

To further reduce system cost, string combining models reduce the number of output conductors between the rooftop box and the inverter. The applicable rapid shutdown boxes include disconnect switches to comply with NEC 2014 690.15(C) *Direct-Current Combiner Disconnects*.

Highlights:

- Meets NEC 690.12 while avoiding the cost of additional conduit making this solution the most cost-effective rapid shutdown product available
- Immediately eliminates voltage and current upon activation
- NEMA 4X enclosure provides added protection from the harshest rooftop conditions
- Multiple string combining models available provide additional savings by reducing the number of DC conductors to the inverter
- Equipment disconnect included in string combining models provide safety and compliance with NEC 2014 combiner-disconnect requirements

Rapid shutdown wiring diagram: 2-RSD system

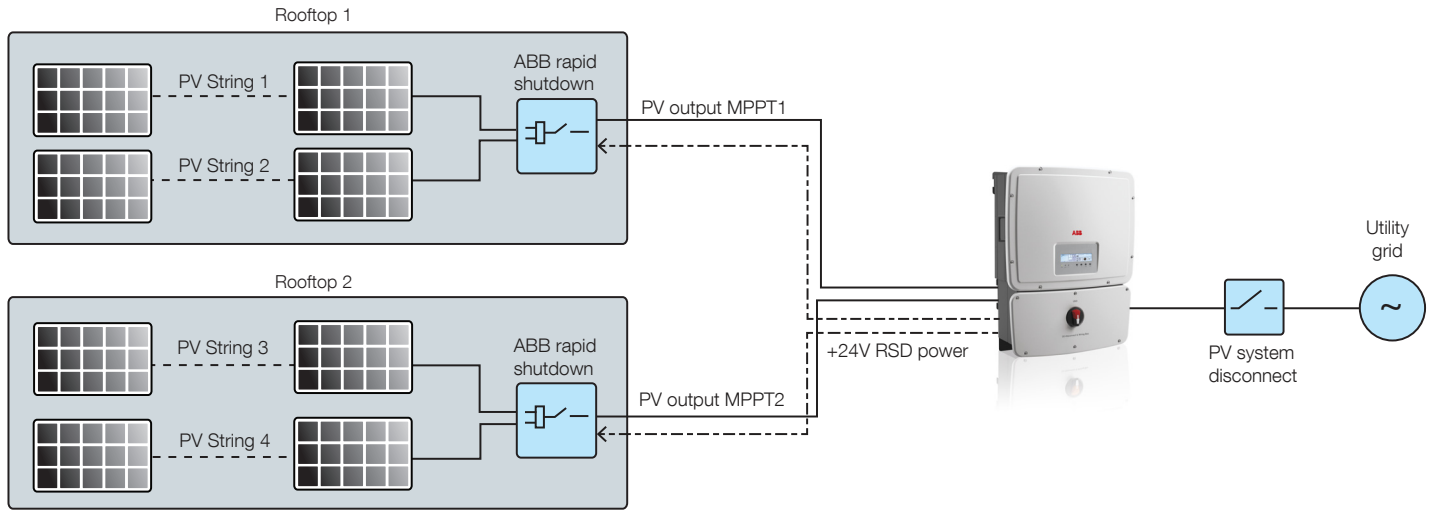

Two RS2-1CN6 boxes may be powered by one power supply. For PV systems requiring two RSD boxes order the RS2-1CN6- kit and one RS2-1CN6 box.

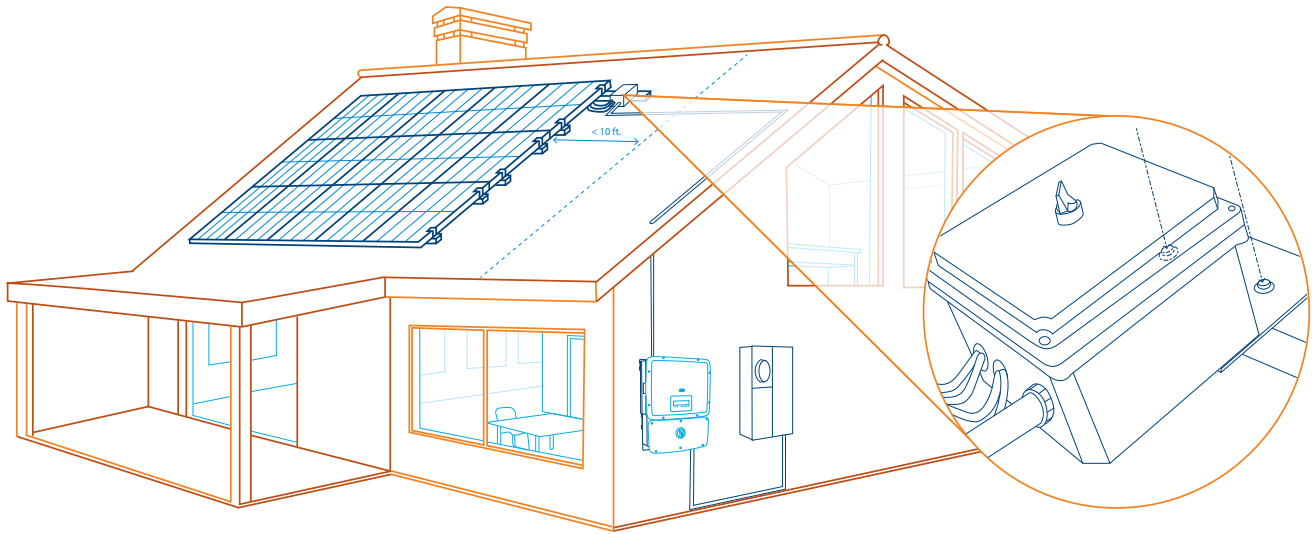

Technical data and types

Type code	2-String pass-through	2-String combined	4-String combined
PV source conductor input			
Max input current (per string)		11.25A	
Max input voltage		600V	
Number of input strings	2	2	4
Conductor size		14-8 AWG	
PV output conductors output			
Number of output circuits	2	1	2
Conductor size		12-6 AWG	
DC disconnect	N/A	Yes	Yes
Control power			
Power consumption	<5W, 24V/0.2A	<2.5W, 24V/0.1A	<5W, 24V/0.2A
Maximum power conductor size		12 AWG	
E-stop button		Optional	
Environmental			
Mounting angle		0-90°	
Dimensions H x W x D		10.54"x8.54"x5.32" (without mounting bracket)	
Weight	6lb	5.8lb	6.2lb
Operating temperature range		-25°C to +70°C	
Enclosure rating		NEMA 4X	
Certifications		UL1741:2010, FCC Part 15 Class B	
Warranty			
Standard warranty		10 Years	
Available models			
Rapid shutdown kit	RS2-2PN6-kit	RS2-1CN6-kit	RS4-2CN6-kit
Rapid shutdown rooftop box for 2-box system	N/A	RS2-1CN6	N/A
Optional emergency stop		1SFA611821R1026	

Information in this document is subject to change without notice

Block diagram for rapid shut down models

RS2-1CN6 two strings in, one PV output

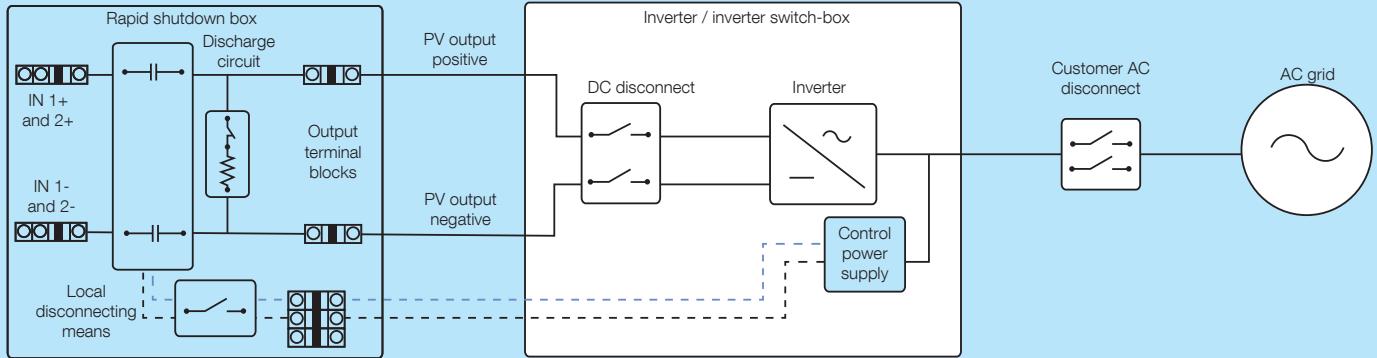

This 2-string model combines the strings to one PV output circuit. The RS2-1CN6 includes a disconnect switch on the front cover to disconnect the PV output conductors from the equipment down stream. Auxillary terminals are provided for connecting an emergency stop button, if desired.

RS4-2CN6 four strings in, two PV outputs

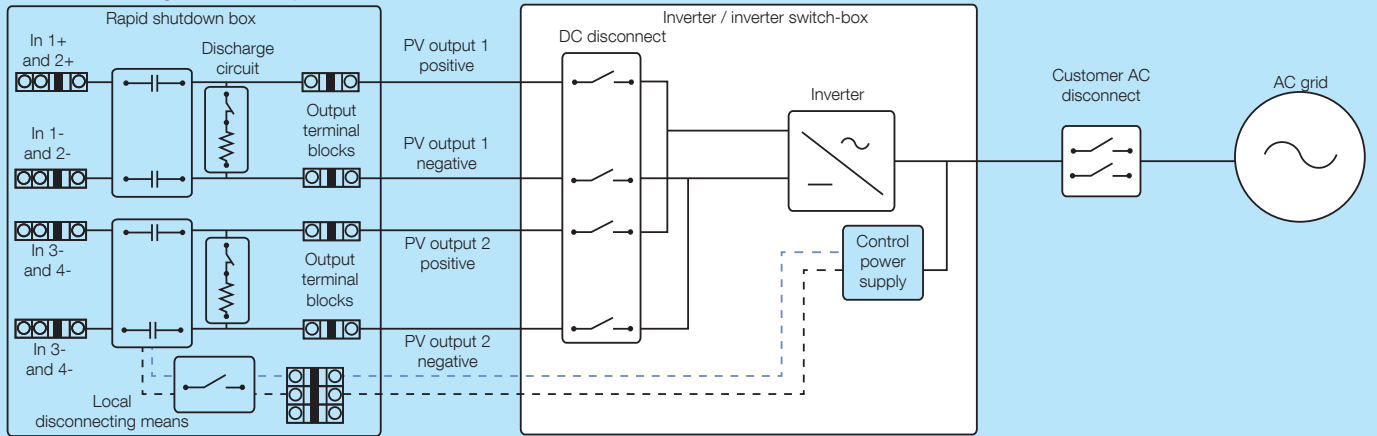

This 4-string model combines 2-strings together in two separate PV output circuits. The RS4-2CN6 includes a disconnect switch on the front cover to disconnect the PV output conductors from the equipment downstream. Auxillary terminals are provided for connecting an emergency stop button, if desired.

RS2-2PN6 two strings in, two strings out

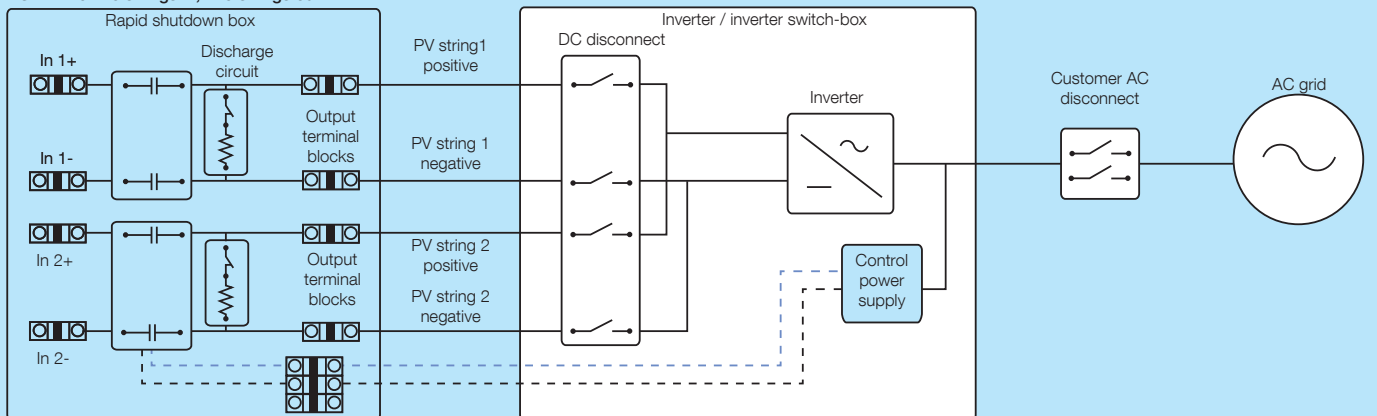

The RS2-2PN6 is a 2-string pass-through with no string combining and no local disconnecting means included. Auxillary terminals are provided for connecting an emergency stop button, if desired.

Support and service

ABB supports its customers with a dedicated, global service organization in more than 60 countries, with strong regional and national technical partner networks providing a complete range of life cycle services.

For more information please contact your local ABB representative or visit:

www.abb.com/solarinverters

www.abb.com

© Copyright 2015 ABB. All rights reserved. Specifications subject to change without notice.