



PV Inverter

SUNNY BOY

3000TL-US / 3800TL-US /

4000TL-US / 5000TL-US / 6000TL-US

Installation Manual

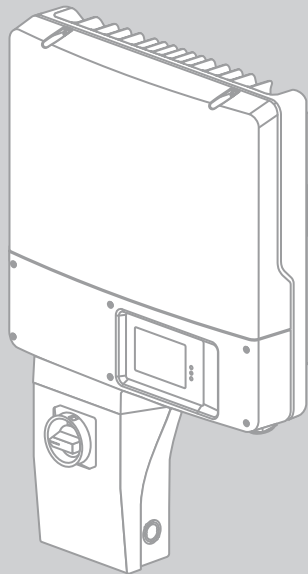

Copyright © 2014 SMA America, LLC. All rights reserved.

No part of this document may be reproduced, stored in a retrieval system, or transmitted, in any form or by any means, electronic, mechanical, photographic, magnetic or otherwise, without the prior written permission of SMA America, LLC.

Neither SMA America, LLC nor SMA Solar Technology Canada Inc. makes representations, express or implied, with respect to this documentation or any of the equipment and/or software it may describe, including (with no limitation) any implied warranties of utility, merchantability, or fitness for any particular purpose. All such warranties are expressly disclaimed. Neither SMA America, LLC nor its distributors or dealers nor SMA Solar Technology Canada Inc. nor its distributors or dealers shall be liable for any indirect, incidental, or consequential damages under any circumstances.

(The exclusion of implied warranties may not apply in all cases under some statutes, and thus the above exclusion may not apply.)

Specifications are subject to change without notice. Every attempt has been made to make this document complete, accurate and up-to-date. Readers are cautioned, however, that SMA America, LLC and SMA Solar Technology Canada Inc. reserve the right to make changes without notice and shall not be responsible for any damages, including indirect, incidental or consequential damages, caused by reliance on the material presented, including, but not limited to, omissions, typographical errors, arithmetical errors or listing errors in the content material.

All trademarks are recognized even if these are not marked separately. Missing designations do not mean that a product or brand is not a registered trademark.

SMA America, LLC
3801 N. Havana Street
Denver, CO 80239 U.S.A.

SMA Solar Technology Canada Inc.
2425 Matheson Blvd. E
8th Floor
Mississauga, ON L4W 5K5
Canada

IMPORTANT SAFETY INSTRUCTIONS

SAVE THESE INSTRUCTIONS

This manual contains important instructions for the following products:



- Sunny Boy 3000TL-US (SB 3000TL-US-22)
- Sunny Boy 3800TL-US (SB 3800TL-US-22)
- Sunny Boy 4000TL-US (SB 4000TL-US-22)
- Sunny Boy 5000TL-US (SB 5000TL-US-22)
- Sunny Boy 6000TL-US (SB 6000TL-US-22)

This manual must be followed during installation and maintenance.

The product is designed and tested according to international safety requirements, but as with all electrical and electronic equipment, certain precautions must be observed when installing and/or operating the product. To reduce the risk of personal injury and to ensure the safe installation and operation of the product, you must carefully read and follow all instructions, cautions and warnings in this manual.





Warnings in this Document

A warning describes a hazard to equipment or personnel. It calls attention to a procedure or practice, which, if not correctly performed or adhered to, could result in damage to or destruction of part or all of the SMA equipment and/or other equipment connected to the SMA equipment or personal injury.

Symbol	Description
 DANGER	DANGER indicates a hazardous situation which, if not avoided, will result in death or serious injury.
 WARNING	WARNING indicates a hazardous situation which, if not avoided, could result in death or serious injury.
 CAUTION	CAUTION indicates a hazardous situation which, if not avoided, could result in minor or moderate injury.
NOTICE	NOTICE is used to address practices not related to personal injury.

Warnings on this Product

The following symbols are used as product markings with the following meanings.

Symbol	Description
	<p>Warning regarding dangerous voltage</p> <p>The product works with high voltages. All work on the product must only be performed as described in the documentation of the product.</p>
	<p>Beware of hot surface</p> <p>The product can become hot during operation. Do not touch the product during operation.</p>
	<p>Electric arc hazards</p> <p>The product has large electrical potential differences between its conductors. Arc flashes can occur through air when high-voltage current flows. Do not work on the product during operation.</p>
	<p>Risk of fire</p> <p>Improper installation of the product may cause a fire.</p>
	<p>Observe the operating instructions</p> <p>Read the documentation of the product before working on it. Follow all safety precautions and instructions as described in the documentation.</p>

General Warnings

⚠ WARNING

General Warnings

All electrical installations must be made in accordance with the local and *National Electrical Code*® ANSI/NFPA 70 or the *Canadian Electrical Code*® CSA C22.1. This document does not and is not intended to replace any local, state, provincial, federal or national laws, regulation or codes applicable to the installation and use of the product, including without limitation applicable electrical safety codes. All installations must conform with the laws, regulations, codes and standards applicable in the jurisdiction of installation. SMA assumes no responsibility for the compliance or non-compliance with such laws or codes in connection with the installation of the product.

The product contains no user-serviceable parts.

For all repair and maintenance, always return the unit to an authorized SMA Service Center.

Before installing or using the product, read all of the instructions, cautions, and warnings in this manual.

Before connecting the product to the electrical utility grid, contact the local utility company. This connection must be made only by qualified personnel.

Wiring of the product must be made by qualified personnel only.

Table of Contents

1	Information on this Document	10
2	Safety	11
2.1	Intended Use	11
2.2	Skills of Qualified Persons	12
2.3	Safety Precautions	12
3	Scope of Delivery	14
4	Product Description	15
4.1	Sunny Boy	15
4.2	DC Disconnect	17
4.3	Type Labels	18
4.3.1	Sunny Boy	18
4.3.2	DC Disconnect	19
4.3.3	Symbols on the Type Labels	20
4.4	Display	21
4.5	Communication Interface	23
4.6	Secure Power Supply (SPS)	23
4.7	Fan Retrofit Kit	23
4.8	Arc-Fault Circuit Interrupter (AFCI)	24
4.9	SD Card Slot	24
4.10	Varistors	24
4.11	SMA OptiTrac Global Peak	24
5	Mounting	25
5.1	Selecting the Mounting Location	25
5.2	Mounting the Wall Mounting Bracket	28
5.3	Mounting the Inverter and DC Disconnect	30
5.4	Attaching the Anti-Theft Device	32
6	Electrical Connection	33
6.1	Safety during Electrical Connection	33

- 6.2 Overview of the Connection Area 34
 - 6.2.1 Connection Area of the Inverter 34
 - 6.2.2 Connection Area of the DC Disconnect 35
- 6.3 AC Connection 36
 - 6.3.1 Conditions for the AC Connection 36
 - 6.3.2 Connecting the Inverter to the Utility Grid 36
- 6.4 DC Connection 39
 - 6.4.1 Safety during DC Connection 39
 - 6.4.2 Conditions for the DC Connection 39
 - 6.4.3 Connecting the PV Array 40
- 6.5 Connecting the Secure Power Supply Module 43
- 7 Commissioning 47**
 - 7.1 Making Settings via the Rotary Switches 47
 - 7.1.1 Overview of the Rotary Switches 47
 - 7.1.2 Changing the Country Data Set and the Display Language 49
 - 7.1.3 Changing the Display Language 50
 - 7.2 Commissioning the Inverter 51
- 8 Configuration 52**
 - 8.1 Changing the Country Data Set Using a Communication Product 52
 - 8.2 Activating and Setting SMA OptiTrac Global Peak 52
- 9 Display and LEDs 53**
 - 9.1 Switching On the Display 53
 - 9.2 Calling Up Messages of the Start Phase 53
 - 9.3 LED Signals 54
- 10 Disconnecting the Inverter from Voltage Sources 55**
 - 10.1 Disconnecting the DC Disconnect from Voltage Sources 57
- 11 Troubleshooting 59**
 - 11.1 Event Messages 59
 - 11.2 Error Messages 60
 - 11.3 Cleaning the Inverter 71

- 11.4 Cleaning the Fan 71
- 11.5 Checking the PV System for Ground Faults 73
- 11.6 Replacing DC Varistors 74
- 11.7 The Message "Electr. arc detected" is displayed. 77
- 12 Decommissioning 79**
- 12.1 Disassembling the Inverter 79
- 12.2 Packing the Inverter 80
- 12.3 Disposing of the Inverter 80
- 13 Technical Data 81**
- 13.1 DC/AC 81
 - 13.1.1 Sunny Boy 3000TL-US. 81
 - 13.1.2 Sunny Boy 3800TL-US. 82
 - 13.1.3 Sunny Boy 4000TL-US. 83
 - 13.1.4 Sunny Boy 5000TL-US. 84
 - 13.1.5 Sunny Boy 6000TL-US. 85
- 13.2 Protective Devices 86
- 13.3 General Data. 87
- 13.4 DC Disconnect. 88
- 13.5 Climatic Conditions 88
- 13.6 Features 88
- 13.7 Torques 89
- 13.8 Data Storage Capacity 89
- 14 Accessories 89**
- 15 Compliance Information 90**
- 16 Contact 91**

1 Information on this Document

Validity

This document is valid for the following device types as of firmware version HP V02.05.00.R, KP V02.50.55.R:

- Sunny Boy 3000TL-US (SB 3000TL-US-22)
- Sunny Boy 3800TL-US (SB 3800TL-US-22)
- Sunny Boy 4000TL-US (SB 4000TL-US-22)
- Sunny Boy 5000TL-US (SB 5000TL-US-22)
- Sunny Boy 6000TL-US (SB 6000TL-US-22)

Target Group





This document is for qualified persons. Only persons with the appropriate skills are allowed to perform the tasks described in this document (see Section 2.2 "Skills of Qualified Persons", page 12).

Additional Information

Links to additional information can be found at www.SMA-Solar.com.

Document title	Document type
Capacitive Leakage Currents	Technical information
Shade Management	Technical information
Module Technology	Technical information

Symbols

Symbol	Explanation
	Indicates information that is important for a specific topic or objective, but is not safety-relevant.
	Indicates a requirement for meeting a specific goal.
	Desired result
	A problem that could occur

Nomenclature

Complete designation	Designation in this document
SMA America Production, LLC	SMA
SMA Solar Technology Canada Inc.	SMA
Sunny Boy	Inverter, product

2 Safety

2.1 Intended Use

The Sunny Boy is a transformerless PV inverter which converts the direct current of a PV array into grid-compliant alternating current and feeds it into the utility grid.

The inverter can be installed in the following grid configurations:

- 208Y/120 VAC Wye
- 120/240 VAC Split phase

The inverter is transformerless and has no galvanic isolation. Therefore, the inverter may only be operated with ungrounded PV arrays. Furthermore, the PV array must be installed in accordance with the *National Electrical Code*[®], Article 690.35 "Ungrounded Photovoltaic Power Systems" and the locally valid regulations for ungrounded PV arrays. Additionally, the PV array (PV modules and cabling) must have protective insulation and the PV modules used must be suitable for use with this inverter. PV modules with a high capacity to ground may only be used if their coupling capacity does not exceed 1,400 nF (for information on how to calculate the coupling capacity, see Technical Information "Capacitive Leakage Currents" at www.SMA-Solar.com).

All components must remain within their permitted operating ranges at all times.

The inverter is suitable for indoor and outdoor use.

- Do not mount the inverter on flammable construction materials.
- Do not mount the inverter in areas where highly flammable materials are stored.
- Do not mount the inverter in areas having a potentially explosive atmosphere.

Only use this product in accordance with the enclosed documentation and with the local standards and directives. Any other use may cause injury to persons or property damage. For safety reasons, it is forbidden to modify the product or install components that are not explicitly recommended for this product or distributed by SMA.

The enclosed documentation is an integral part of this product.

- Read and adhere to the documentation.
- Keep the documentation in a convenient place for future reference.

2.2 Skills of Qualified Persons

The tasks described in this document may only be performed by qualified persons. The qualified person must have the following skills:

- Knowledge of how an inverter works and is operated
- Training in how to deal with the dangers and risks associated with installing and using electrical devices and plants
- Training in the installation and commissioning of electrical devices and plants
- Knowledge of all applicable standards and directives
- Knowledge of and adherence to this document and all safety precautions

2.3 Safety Precautions

DANGER

Danger to life from electric shock due to high voltages in the inverter

High voltages that can cause fatal electric shocks are present in the live components of the inverter.

- All work on the inverter may only be carried out by qualified persons.
- Prior to performing any work on the inverter, disconnect the inverter on the AC and DC sides (see Section 10 "Disconnecting the Inverter from Voltage Sources", page 55).
- Only operate the inverter with the enclosure lid closed.
- Do not open the upper enclosure lid.

Danger to life from electric shock due to damaged devices

Operating a damaged inverter can lead to hazardous situations that result in death or serious injuries due to electric shock.

- Only operate the inverter if it is technically safe and in full working order.
- Check the inverter regularly for visible damage.
- Only operate the inverter if there is no visible damage.

CAUTION

Risk of burns due to hot surfaces

The surface of the inverter can become very hot. Touching the surface can result in burns.

- Do not touch hot surfaces.
- During operation, do not touch any parts other than the lower enclosure lid of the inverter.
- Observe the safety messages on the inverter.

NOTICE**Damage to the inverter due to electrostatic discharge**

Touching electronic components can cause damage to or destroy the inverter through electrostatic discharge.

- Ground yourself before touching any components.

**Observe local regulations**

All electrical installations must comply with the electrical standards applicable on-site and the *National Electrical Code*® (ANSI/NFPA 70). Installations in Canada must comply with the applicable Canadian standards.

3 Scope of Delivery

Check the scope of delivery for completeness and any externally visible damage. Contact your distributor if the scope of delivery is incomplete or damaged.

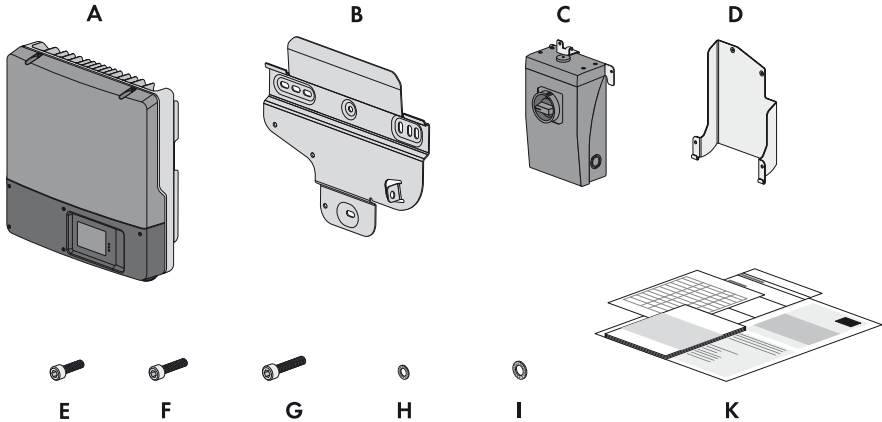

Figure 1: Components included in the scope of delivery

Item	Quantity	Description
A	1	Inverter
B	1	Wall mounting bracket for the inverter
C	1	DC Disconnect
D	1	Wall mounting bracket for the DC Disconnect
E	3	M5 x 8 cheese-head screw
F	2	M5 x 12 cheese-head screw
G	1	M6 x 16 cheese-head screw
H	6	M5 conical spring washer (including 1 spare)
I	1	M6 conical spring washer
K	1	Installation manual, user manual, production test report, supplementary sheet with the default settings

4 Product Description

4.1 Sunny Boy

The Sunny Boy is a transformerless PV inverter which converts the direct current of a PV array into grid-compliant alternating current and feeds it into the utility grid.

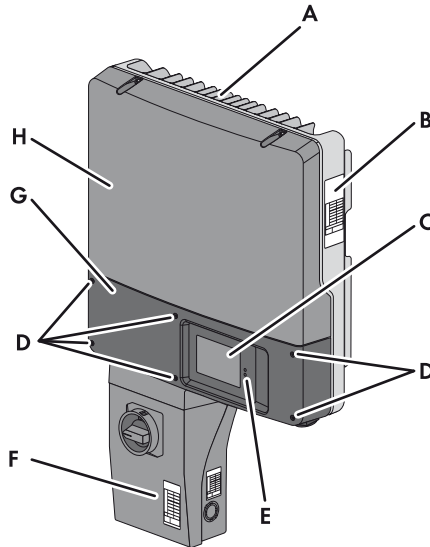





Figure 2: Sunny Boy design

Item	Description
A	Cooling fins
B	Type label
C	Display
D	Lower enclosure lid screws
E	LEDs
F	DC Disconnect
G	Lower enclosure lid
H	Upper enclosure lid

The Sunny Boy is a multi-string inverter that has two input areas, **A** and **B**, each with its own MPP tracker. This continually determines the maximum power point and controls the voltage on the PV modules accordingly. The two separate MPP trackers make it possible to connect different PV strings to input areas **A** and **B**. The PV strings may vary in the number of PV modules, their orientation to the sun and shading.

Symbols on the Inverter

Symbol	Description	Explanation
	Inverter	This symbol defines the function of the green LED. The green LED indicates the operating state of the inverter.
	Observe the documentation.	This symbol defines the function of the red LED. The red LED indicates an error. Read this document for instructions on how to correct the error.
	Communication	This symbol defines the function of the blue LED. The blue LED indicates the communication state of the inverter.
	Equipment grounding conductor terminal	Connection for the AC equipment grounding conductor

4.2 DC Disconnect

The DC Disconnect is a DC load-break switch which safely disconnects the PV array from the inverter.

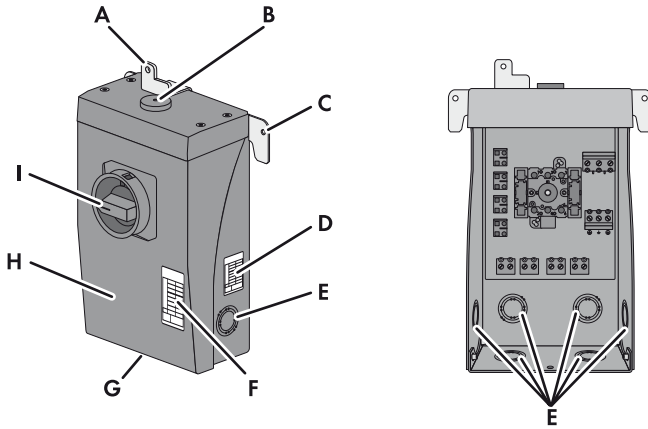

Figure 3: DC Disconnect design

Item	Description
A	Bracket for grounding the DC Disconnect enclosure
B	Rubber grommet for the enclosure opening
C	Bracket for hanging in the retainer
D	Type label 1
E	Conduit knockouts
F	Type label 2
G	Enclosure lid screws
H	Enclosure lid
I	Switch

Symbols on the DC Disconnect

Symbol	Description	Explanation
	Equipment grounding conductor terminal	Connection for the DC equipment grounding conductors

4.3 Type Labels

4.3.1 Sunny Boy

The type label provides a unique identification of the inverter. The type label is located on the right-hand side of the enclosure.

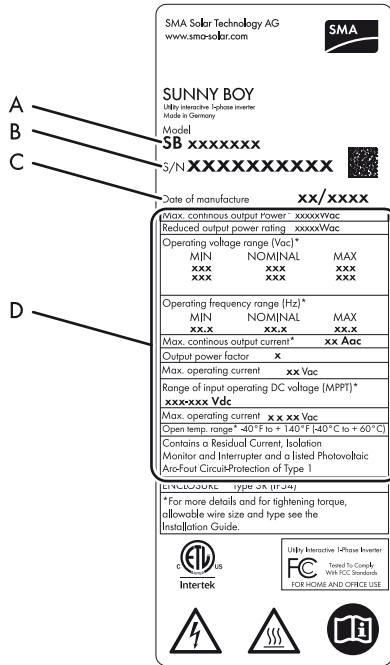

Figure 4: Type label design

Item	Description	Explanation
A	Model	Inverter device type
B	S/N	Inverter serial number
C	Date of manufacture	Inverter manufacture date (month/year)
D	Device-specific characteristics	-

The information on the type label is required for both safe operation of the inverter and for customer support from the SMA Service Line. The type label must remain permanently affixed to the inverter.

4.3.2 DC Disconnect

The type label provides a unique identification of the DC Disconnect. The type label is located on the right-hand side of the enclosure.

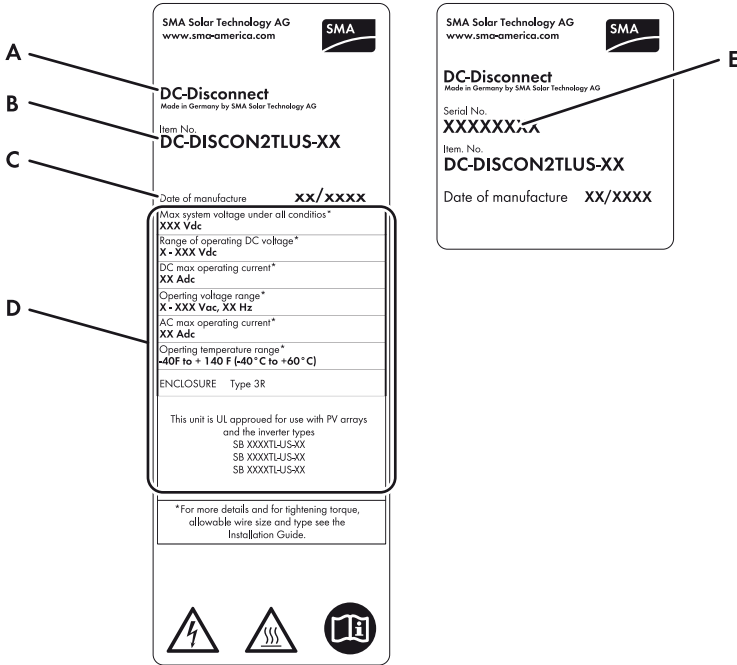







Figure 5: Layout of the type label

Item	Description	Explanation
A	-	Product name
B	Item No.	DC Disconnect device type
C	Date of manufacture	DC Disconnect manufacture date (month/year) of the
D	Device-specific characteristics	-
E	Serial No.	DC Disconnect serial number

You will require the information on the type label to use the DC Disconnect safely and when seeking customer support from the SMA Service Line. The type label must remain permanently affixed to the DC Disconnect.

4.3.3 Symbols on the Type Labels

Symbol	Description	Explanation
	Danger to life due to high voltages	The product operates at high voltages. All work on the inverter may only be carried out by qualified persons.
	Risk of burns due to hot surfaces	The product can become hot during operation. Avoid contact during operation. Allow the product to cool down sufficiently before carrying out any work. Wear personal protective equipment such as safety gloves.
	Observe the documentation.	Observe all documentation that is supplied with the product.
	ETL test mark	The product has been certified by Intertek as being in accordance with the applicable directives.
	FCC test mark	The product complies with the requirements of the applicable FCC standards.

4.4 Display

The display shows the current operating data of the inverter (e.g. current power, daily energy, total energy) as well as events or error messages. The power and energy are displayed as bars in the diagram.

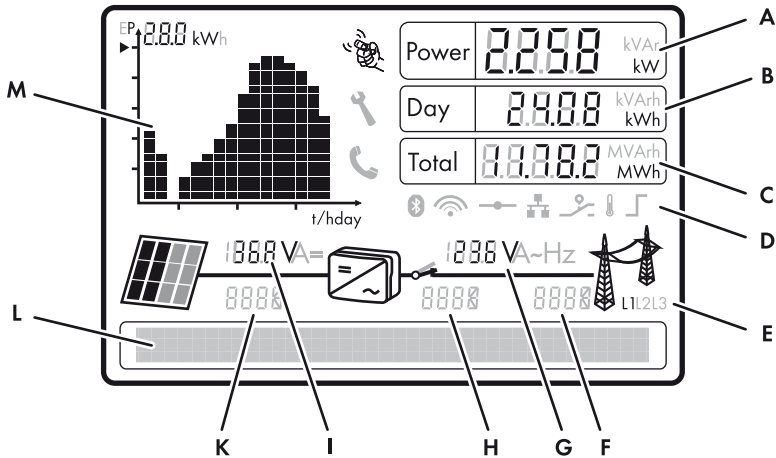













Figure 6: Display layout (example)

Position	Description	Explanation
A	Power	Current power
B	Day	Daily energy
C	Total	Total energy generated since the initial start-up of the inverter
D	Active functions	Displays the activated or active functions for communication, network system services or temperature derating
E	Line conductor	Line conductor involved for the values displayed
F	Event number relating to the utility grid	Event number of errors relating to the utility grid
G	Output voltage/output current	Displays output voltage and output current of a line conductor in alternation
H	Event number relating to the inverter	Event number of errors relating to the inverter
I	Input voltage/input current	Displays input voltage and input current of an input in alternation

Position	Description	Explanation
K	Event number relating to the PV array	Event number of errors relating to the PV array
L	Text line	Displays an event message or error message
M	Power and yield curve	Displays the power curve of the last 16 feed-in hours or the energy yields of the last 16 days <ul style="list-style-type: none"> In order to switch between the displays, tap once on the enclosure lid.

Symbols on the Display

Symbol	Description	Explanation
	Tapping	You can operate the display by tapping it (see Section 9 "Display and LEDs", page 53).
	Telephone receiver	Indicates a fault that cannot be corrected on site <ul style="list-style-type: none"> Contact the SMA Service Line
	Wrench	Indicates a fault that can be corrected on site by a qualified person
	Speedwire connection	Indicates that communication via Speedwire is active and that there is a network connection
	Webconnect function	Indicates that there is a connection to Sunny Portal
	Temperature symbol	Indicates that the power of the inverter is limited due to excessive temperature
	Power limitation	Indicates that external active power limitation via the Power Reducer Box is active
	PV array	-
	Inverter	-

Symbol	Description	Explanation
	Grid relay	Grid relay closed: indicates that the inverter is feeding into the utility grid Grid relay open: indicates that the inverter is disconnected from the utility grid
	Utility grid	-

4.5 Communication Interface

The inverter can be fitted with a communication interface (e.g. RS485 or Speedwire with Webconnect function). This communication interface enables the inverter to communicate with SMA communication products or other inverters (for information on supported products, see www.SMA-Solar.com).

You can only set the inverter parameters via SMA communication products.

Depending on the type of communication, RS485 or Speedwire, the parameters and messages are displayed differently on the communication products.

Example: How the country data set parameter is displayed

For communication with RS485: **CntrySet** parameter

For communication with Speedwire: **Set country standard** parameter

You can adjust the country data set of the inverter before commissioning or within the first ten operating hours via the two rotary switches in the inverter. All other operating parameters can only be set via communication products.

4.6 Secure Power Supply (SPS)

The inverter has an SPS module that can supply the PV array energy to an additional outlet connected to the inverter in the event of grid failures of longer durations. The SPS module also has a connection for the fan retrofit kit, enabling an external fan to be controlled.

4.7 Fan Retrofit Kit

The fan retrofit kit is used for additional inverter cooling at high ambient temperatures (for information on installation and configuration, see the fan retrofit kit installation manual). The fan retrofit kit can be retrofitted, installed at the factory if specified in the order, or included in the regular scope of delivery.

The SB 6000TL-US is equipped with a fan as standard.

4.8 Arc-Fault Circuit Interrupter (AFCI)

In accordance with the *National Electrical Code*®, Article 690.11, the inverter has a system for the recognition of electric arc detection and interruption. An electric arc with a power of 300 W or greater must be interrupted by the AFCI within the time specified by UL 1699B. A tripped AFCI can only be reset manually. You can deactivate the automatic arc fault detection and interruption (AFCI) via a communication product in "Installer" mode if you do not require this function. The 2011 edition of the *National Electrical Code*®, Section 690.11 stipulates that newly installed PV systems attached to a building must be fitted with a means of detecting and disconnecting serial electric arcs (AFCI) on the PV side.

4.9 SD Card Slot

The inverter is equipped with an SD card slot. You can use the SD card when required to update the inverter firmware.

4.10 Varistors

The DC Disconnect is equipped with four varistors on the DC side. Varistors are voltage-dependent resistors that protect the inverter on the DC side against surge overvoltages. It may be necessary under certain circumstances to replace the varistors (see Section 11.6 "Replacing DC Varistors", page 74).

Despite this protection against surge overvoltages, PV arrays must be designed in such a way that the maximum system voltage of the inverter is not exceeded (see Section 13 "Technical Data", page 81).

4.11 SMA OptiTrac Global Peak

SMA OptiTrac Global Peak is a further development of the MPP tracking tool SMA OptiTrac. MPP tracking is a process that determines the highest usable power in the PV system at any given time. The power generated by the PV array depends on the level of solar irradiation and the temperature of the PV modules. As a result, the optimum operating point for maximum power (MPP) changes constantly throughout the day.

SMA OptiTrac ensures that the operating point of the inverter always follows the MPP exactly. In addition, with the aid of SMA OptiTrac Global Peak the inverter can detect the presence of several maximum power points within the available operating range, such as may occur with partially shaded strings in particular. The available power of the partially shaded strings can therefore be almost completely fed into the utility grid.

SMA OptiTrac Global Peak is deactivated as standard and should, in the event of partially shaded PV modules, be activated and set via a communication product (see Section 8.7).

5 Mounting

5.1 Selecting the Mounting Location

Requirements for the mounting location:

⚠ WARNING

Danger to life due to fire or explosion

Despite careful construction, electrical devices can cause fires.

- Do not mount the inverter in areas where highly flammable materials are stored.
- Do not mount the inverter in areas having a potentially explosive atmosphere

⚠ CAUTION

The inverter can become hot during operation

Touching the enclosure can result in burn injuries.

- Install the inverter in such a way that it cannot be touched accidentally.

- The inverter must be mounted to a solid building ground (e.g., concrete or block wall) or on drywall to a beam or stud.
- In living areas, make sure that the building ground is not made of plasterboard or similar. When in operation, the inverter makes noises which can be perceived as a nuisance.
- The mounting location must be suitable for the weight and dimensions of the inverter with DC Disconnect (see Section 13 "Technical Data", page 81).
- The mounting location must not be exposed to direct sources of water spray such as sprinklers or gutters.
- Climatic conditions must be met (see Section 13 "Technical Data", page 81).
- The mounting location should be freely and safely accessible at all times without the necessity for any auxiliary equipment, such as scaffolding or lifting platforms. Non-fulfillment of these criteria may restrict servicing.
- The mounting location should not be exposed to direct solar irradiation. Direct solar irradiation can increase the operating temperature of the inverter. As a result, the inverter reduces its power output in order to remain within the operating limits.
- To ensure optimal operation, the ambient temperature must be below 104 °F (40 °C). The inverter can, however, be operated at higher ambient temperatures without risk in the event of any possible reductions in output power.

Dimensions for mounting:

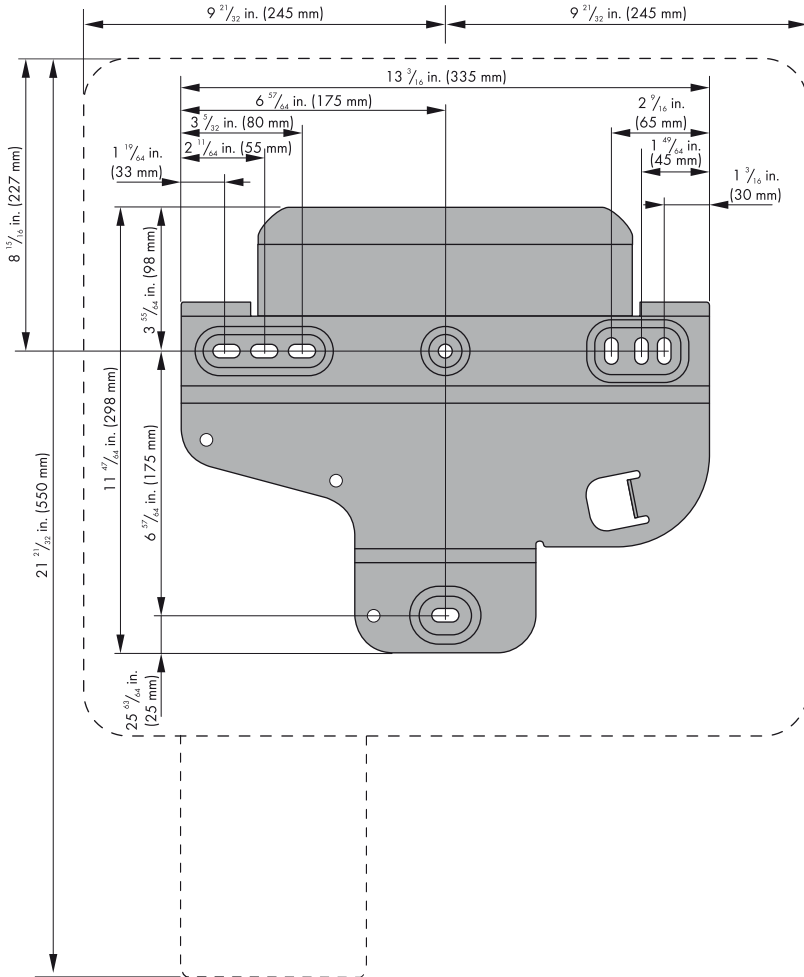

Figure 7: Wall mounting bracket dimensions

Recommended Clearances

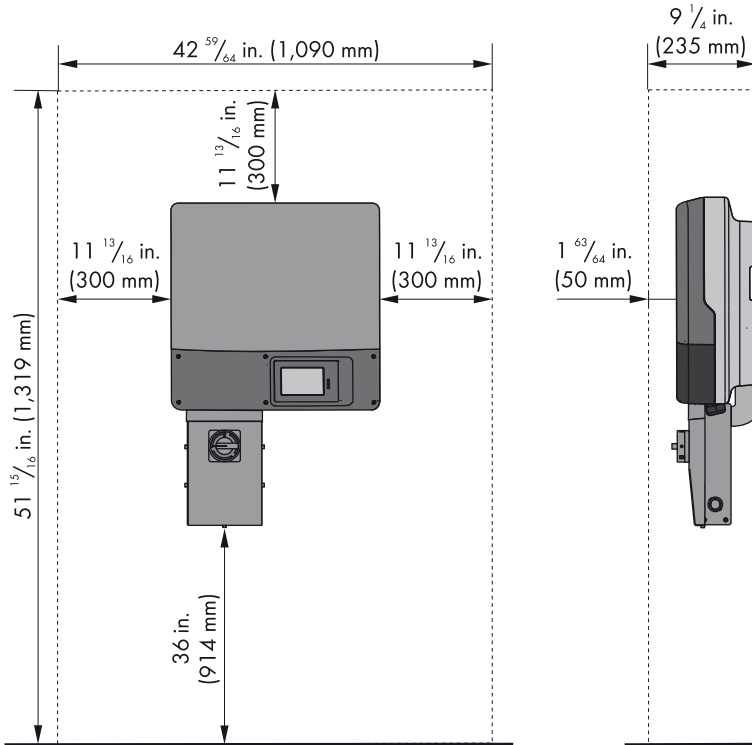

Figure 8: Recommended clearances

- To ensure optimal operation, maintain recommended clearances to walls, other inverters or objects. This will prevent the inverter from reducing its power due to high temperatures.
- If the inverter is mounted outdoors, the clearance between the DC Disconnect and the floor must be 3 ft. (914 mm). This prevents the ingress of splashing water into the DC Disconnect.
- Do not place or hang any objects on the inverter.

Observe the permitted mounting position:

Figure 9: Permitted and prohibited mounting positions

- Mount the inverter in a permitted mounting position with the display at eye level. This ensures that there can be no ingress of moisture into the inverter and that you can read display messages and LED signals without any difficulty.

5.2 Mounting the Wall Mounting Bracket**Additionally required mounting material (not included in the scope of delivery):**

- 2 or 3 screws (minimum diameter $\frac{1}{4}$ in. (6 mm)) that are suitable for the foundation
- 2 or 3 washers (minimum external diameter $\frac{3}{4}$ in. (18 mm)) that are suitable for the screws
- 2 or 3 screw anchors that are suitable for the foundation. Do not use hollow-wall anchors or toggle bolts for mounting on drywall.
- If the inverter is to be protected against theft, 1 padlock (see Section 5.4 "Attaching the Anti-Theft Device", page 32)

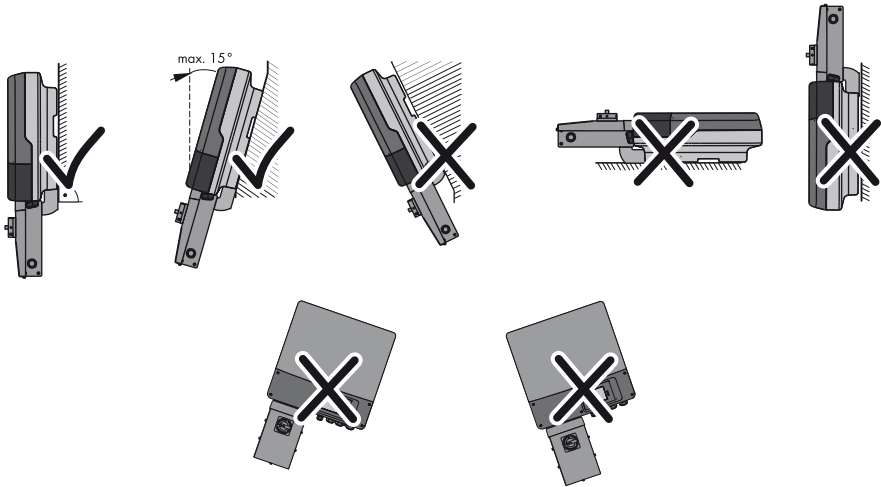
1. Attach the DC Disconnect bracket to the wall mounting bracket of the inverter using the screws and conical spring washers included in the delivery and tighten them with an Allen key (AF 4) (torque: 44 in.-lbs (5.0 Nm)). Tighten the two upper screws (M5x12) from the rear and the lower (M5x8) from the front.

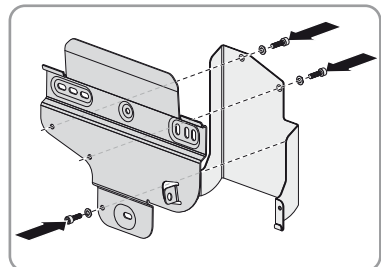

2. Align the wall mounting bracket horizontally at the mounting location.

3. **⚠ WARNING**

Danger to life due to electric shock or explosion if you drill into supply lines

There may be gas pipes or electric cables behind the mounting points which could be damaged when drilling the holes for the wall mounting bracket.

- Make sure that there are no supply lines behind the mounting points.
4. Mark the position of the drill holes using the wall mounting bracket and screw the wall mounting bracket onto the wall using the screws and washers.

- For mounting on a stone wall, use one hole on the right-hand and left-hand side and the lower hole in the wall mounting bracket.

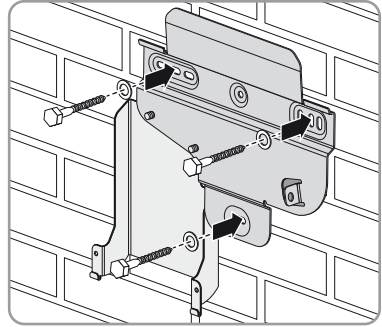

- For mounting on a stud or post in a drywall construction, use the two holes at the center.

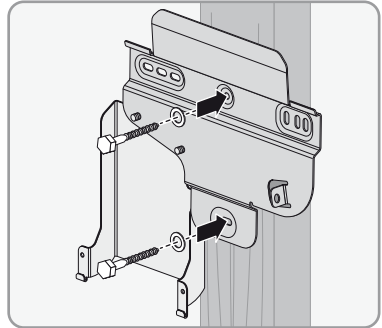

5.3 Mounting the Inverter and DC Disconnect

1. **CAUTION**

Risk of injury when lifting the inverter, or if it is dropped

The inverter is heavy (see Section 13 "Technical Data", page 81). Risk of injury exists due to incorrect lifting and due to the inverter falling during transport or when hanging in the wall mounting bracket.

- Lift and transport the inverter horizontally in the mounting position. Use the recessed grips on the sides for this.

2. Hang the inverter in the wall mounting bracket.

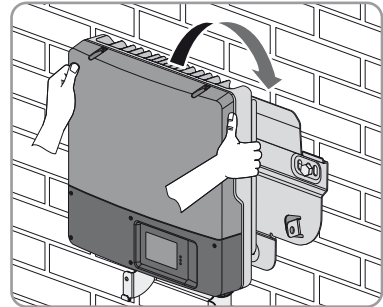

3. Ensure that the inverter is securely in place.

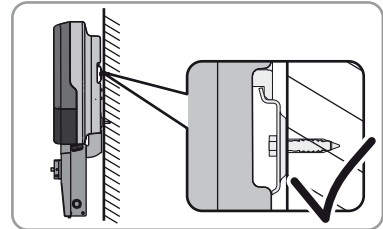

4. Remove the lower lid.

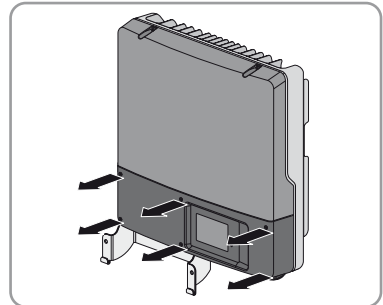

5. Carefully pierce the rubber grommet on the upper side of the DC Disconnect using a screwdriver.

6. Place the DC Disconnect into the retainer from the front.

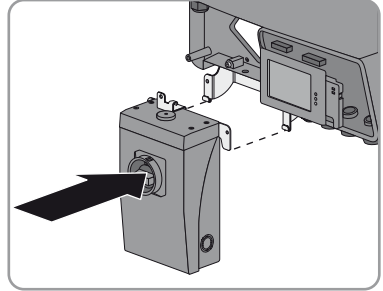

7. Attach the DC Disconnect to the ground connection on the inverter using the grounding bracket. Use the M6x8 screw included in the delivery, the corresponding conical spring washer and an Allen key (AF 5) (torque: 53 in-lbs. (6 Nm)). When doing so, ensure that the holes in the lateral brackets of the DC Disconnect are flush with the holes in the retainer.

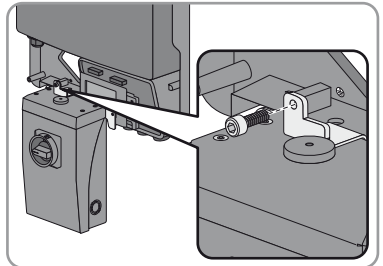

8. Attach the DC Disconnect to the bracket using the M5x8 screws and conical spring washers included in the delivery and an Allen key (AF 4) (torque: 44in-lbs. (5 Nm)).

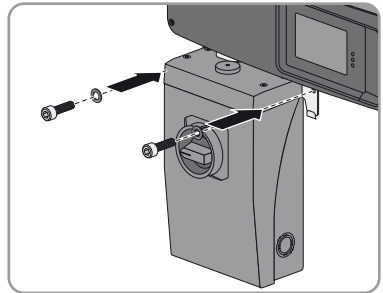

9. Feed the inverter DC cable through the rubber grommet on the upper side of the DC Disconnect.

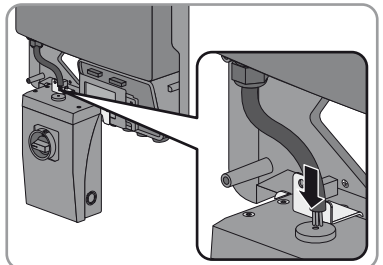

5.4 Attaching the Anti-Theft Device

You can protect the inverter from theft by installing a padlock. The padlock secures the inverter to the wall mounting bracket.

The padlock must meet the following requirements:

- The material should be rust-proof.
- The lock shackle should be hardened.
- The lock cylinder should be secured.
- If mounted outdoors, the padlock should be weather-proof.

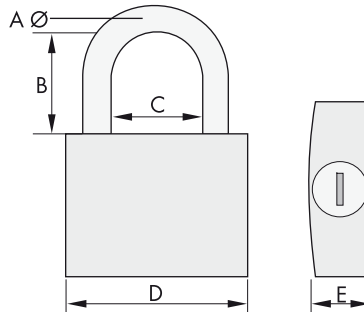
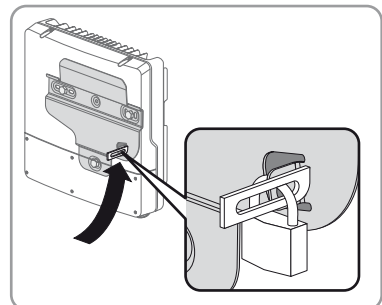

Figure 10: Dimensions of the padlock as anti-theft device

Item	Dimensions
A	6 mm (0.23 in.)
B	21 mm to 33 mm (0.83 in. to 1.30 in.)
C	20 mm to 33 mm (0.79 in. to 1.30 in.)
D	40 mm to 60 mm (1.57 in. to 2.36 in.)
E	13 mm to 21 mm (0.51 in. to 0.83 in.)

1. Place the shackle of the padlock through the metal bracket on the wall mounting bracket and through the bracket on the rear of the inverter. Whilst doing so, move the shackle outward from the center of the inverter.



2. Close the shackle.

6 Electrical Connection

6.1 Safety during Electrical Connection

⚠ DANGER

Danger to life from electric shock due to high voltages

High voltages are present in the DC cables and later during operation in the conductive components of the inverter. These can cause fatal electric shocks.

- Before working on the inverter, always disconnect the inverter from all voltage sources as described in Section 10.
- Do not open the upper enclosure lid.

NOTICE

Damage to the seal of the enclosure lid during sub-zero conditions

When opening the enclosure lid during sub-zero conditions, the seal of the enclosure lid can be damaged. There may be an ingress of moisture, which can damage the inverter.

- Do not open the inverter when the outside temperature is below 23 °F (- 5 °C).

Damage to the inverter due to electrostatic discharge

Touching electronic components can cause damage to or destroy the inverter through electrostatic discharge.

- Ground yourself before touching any components.

Damage to the inverter due to moisture ingress

Electronic components in the inverter can be destroyed or damaged as a result of the ingress of moisture.

- Only use listed conduit fittings for inserting the conduits into the inverter and the DC Disconnect.
- For outdoor installations, only use rain-tight conduit fittings or conduit fittings for wet locations.

Damage to or failure of the inverter due to incorrectly connected cables

Insecure or high-resistance cable connections (such as incorrectly installed twist-on connectors) can cause ground faults or arc faults that can lead to the damage or failure of the inverter.

- Select and correctly install cable connections that ensure secure, low-resistance connections for all electrical connections in the PV system.

i Observe local regulations

All electrical installations must comply with the electrical standards applicable on-site and the *National Electrical Code*® (ANSI/NFPA 70). Installations in Canada must comply with the applicable Canadian standards.

6.2 Overview of the Connection Area

6.2.1 Connection Area of the Inverter

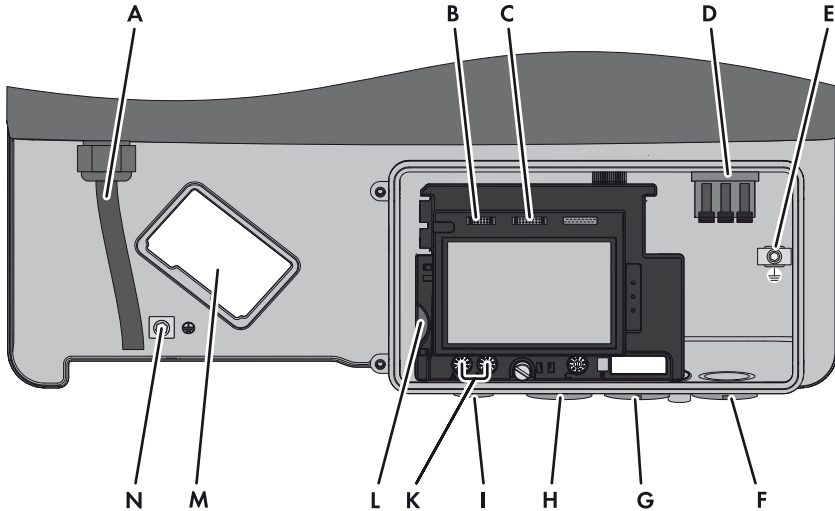

Figure 11: Connection area inside the inverter

Item	Description	Explanation
A	DC cable	For the connection of the inverter and DC Disconnect
B	Pin connector	For the connection of the SPS module
C	Pin connector	For the connection of the communication interface
D	Terminal	For the AC cables
E	Ground connection	For the equipment grounding conductor
F	Enclosure opening ($\frac{3}{4}$ in. (19 mm))	For the conduit fitting for inserting the AC cables
G	Enclosure opening ($\frac{3}{4}$ in. (19 mm))	For the conduit fitting for insertion of the optional data cable
H	Enclosure opening ($\frac{3}{4}$ in. (19 mm))	For the conduit fitting for insertion of the connection cable of the SPS module
I	Enclosure opening	For the cable gland used to insert the connection cable for the fan retrofit kit*
K	Rotary switches	For setting the language and country standard

Item	Description	Explanation
L	Slot	For SD card
M	Retainer	For the retrofit fan
N	Ground connection	For the DC Disconnect grounding bracket

6.2.2 Connection Area of the DC Disconnect

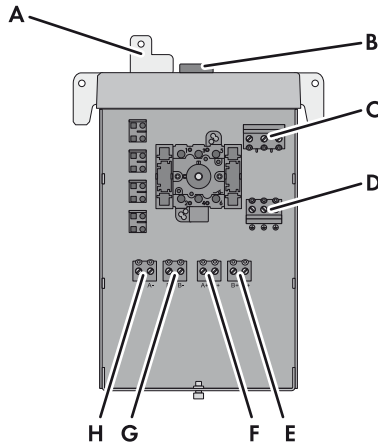

Figure 12: Connection areas of the DC Disconnect

Item	Description	Explanation
A	Grounding bracket	For attachment to the grounding screw in the inverter
B	Rubber grommet	For insertion of the connection cable from the inverter
C	Screw terminals	For the connection of the connection cable from the inverter
D	Screw terminals	For the connection of the DC equipment grounding conductor
E	Screw terminals	For the connection of the strings (input B+)
F	Screw terminals	For the connection of the strings (input A+)
G	Screw terminals	For the connection of the strings (input B-)
H	Screw terminals	For the connection of the strings (input A-)

6.3 AC Connection

6.3.1 Conditions for the AC Connection

Cable requirements:

- Conductor cross-section L1, L2, N: 12 AWG to 6 AWG (3.3 mm² to 13.3 mm²)
- Conductor cross-section equipment grounding conductor: 12 AWG (3.3 mm²)
- Isolation stripping length: 1/2 in. (12 mm)
- Solid or stranded wire of copper with no more than 19 single wires
- The cables must be designed in accordance with local directives and the *National Electrical Code*[®]. Influencing factors for cable dimensioning are, for example, the nominal AC current, the type of cable, the routing method, cable bundling, ambient temperature, and maximum desired line losses.

Additionally required mounting material (not included in the scope of delivery):

- 1 conduit fitting (3/4 in. (19 mm)), rain-tight or for wet locations when installed outdoors
- 1 conduit (3/4 in. (19 mm))

Load-break switch and cable protection:

NOTICE

Damage to the inverter through the use of fuses as disconnecting units in the output circuit of the inverter

Fuses must not be used as disconnecting units, even if they are installed in a fuse holder listed as being a load-break switch.

- If fuses are installed as overcurrent protection in the output circuit of the inverter, a disconnection switch or another load-break switch suitable for the load must be installed as a disconnecting unit in the output circuit of the inverter.
- Use a circuit breaker as (a) load-break switch, for example. These can be used both as overcurrent protection and as disconnecting unit.
- In plants with multiple inverters, protect every inverter with a separate circuit breaker or another overcurrent protective device. Observe the maximum permissible fuse protection (see Section 13 "Technical Data", page 81). In doing so, you avoid residual voltages being present at the respective cables after a disconnection from the utility grid.
- Loads installed between the inverter and the circuit breaker must be protected separately.

6.3.2 Connecting the Inverter to the Utility Grid

Requirements:

- The country data set and the display language must be correctly set (see Section 7.1 "Making Settings via the Rotary Switches", page 47).
- The connection requirements of the grid operator must be met.

- The line voltage must be within the permissible range. The exact operating range of the inverter is specified in the operating parameters.
1. Switch off or open all AC disconnecting switches and circuit breakers in the output circuit of the inverter and secure against reconnection.
 2. Ensure that no voltage is present between the AC cables to be connected.
 3. Remove all six screws of the lower enclosure lid using an Allen key (AF 3) and remove the enclosure lid.
 4. Loosen the screw on the display and flip the display up until it clicks into place.

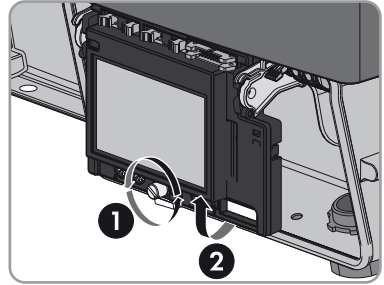

5. Lead the conduit with the AC cables through the enclosure opening into the inverter and screw the conduit fitting tight.
6. Strip the insulation of L1, L2, N and the equipment grounding conductor each by $1/2$ in. (12 mm).
7. Connect L1, L2 and N to the AC terminals labelled for this purpose:
 - Raise the safety levers on the terminals as far as possible.

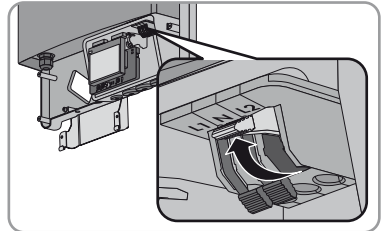

- Lead the conductors fully into the terminals.

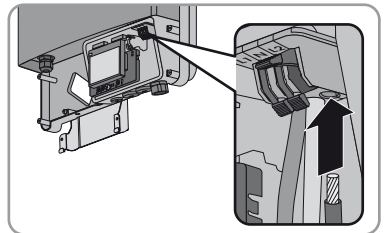

8. **⚠ CAUTION****Danger of crushing when safety levers snap shut**

The safety levers close by snapping down fast and hard.

- Only press the safety levers on the terminals down with your thumb. Do not grasp the entire AC connecting terminal plate and do not place your fingers under the safety levers.

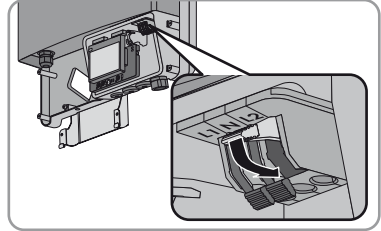

9. Ensure that the conductors are securely in place in the terminals.
10. Loosen the cheese-head screw on the ground connection using an Allen key (AF 5).
11. Lead the clamping bracket over the equipment grounding conductor. Arrange the equipment grounding conductor to the left when doing so.

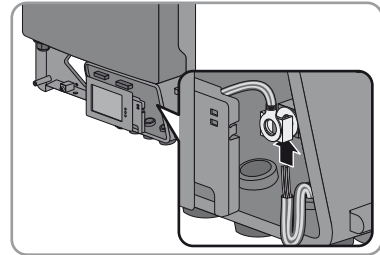

12. Secure the conical spring washer, the grounding cable of the SPS module and the clamping bracket using the cheese-head screw (torque 53 in-lbs. (6 Nm)). The teeth of the conical spring washer must face the clamping bracket.

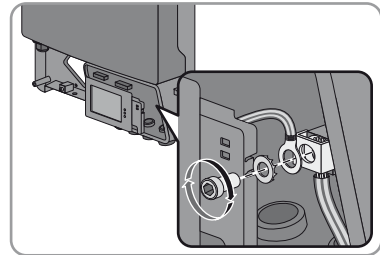

13. If the display is raised, lower the display and tighten the display screw by hand.

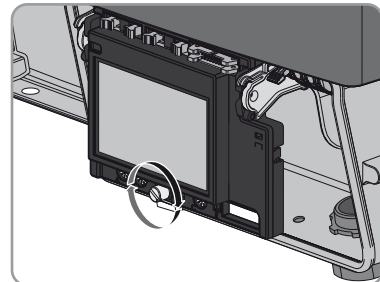

6.4 DC Connection

6.4.1 Safety during DC Connection

⚠ DANGER

Danger to life due to high voltages on DC conductors

Risk of death or serious injury due to electric shock from touching a DC conductor.

- Do not touch the DC conductors.

Danger of electric arcs due to reversed-pole DC conductors

Dangerous electric arcs can form when the DC conductors are connected to the incorrect poles on the inverter.

- Only make the DC connection as described in this document.
- Ensure the correct polarity of the DC conductors.

6.4.2 Conditions for the DC Connection

The inverter is transformerless and has no galvanic isolation. Therefore, the inverter may only be operated with ungrounded PV arrays. Furthermore, the PV array must be installed in accordance with the *National Electrical Code*®, Article 690.35 "Ungrounded Photovoltaic Power Systems" and the locally valid regulations for ungrounded PV arrays. Additionally, the PV array (PV modules and cabling) must have protective insulation and the PV modules used must be suitable for use with this inverter.

The inverter has two input areas A and B. The strings per input area must be designed identically.

Requirements for the PV Modules

- The limiting values for the maximum system voltage and the maximum short-circuit current of the inverter must not be exceeded (see Section 13 "Technical Data", page 81).
- The PV modules and strings connected to one input area should have the same electrical properties based on the manufacturer information.
- For an optimum yield all PV modules of one input area should be mounted with the same inclination and azimuth orientation.

Cable requirements:

- Solid or stranded wire of copper with no more than 19 single wires
- Conductor cross-section: 12 AWG to 6 AWG (5.3 mm² to 13.3 mm²)
- The cables must be designed in accordance with local directives and the *National Electrical Code*®. Influencing factors for cable dimensioning are, for example, the nominal DC current, the type of cable, the routing method, cable bundling, ambient temperature, and the maximum desired line losses.

Additionally required mounting material (not included in the scope of delivery):

- Conduit fittings ($\frac{3}{4}$ in. (19 mm)), rain-tight or for wet locations when installed outdoors
- Conduits ($\frac{3}{4}$ in. (19 mm))

6.4.3 Connecting the PV Array**NOTICE****Destruction of the inverter due to overvoltage**

If the open-circuit voltage of the PV modules exceeds the maximum system voltage of the inverter, the inverter can be destroyed by overvoltage.

- Ensure that the open-circuit voltage of the PV modules does not exceed the maximum input voltage of the inverter.
- Otherwise, do not connect strings to the inverter; check the design of the PV system.

1. Switch off or open all AC disconnecting switches and circuit breakers in the output circuit of the inverter and secure against reconnection.
2. If an external DC disconnecting switch is available, switch off or open the DC disconnecting switch.
3. If there is no external DC disconnecting switch available, cover the PV modules with opaque material or disconnect the connectors on the PV modules.
4. Ensure that no DC voltage is present on the DC cables of the PV array.
5. Loosen the screw on the lower side of the DC Disconnect using an Allen key (AF 4) and remove the lid of the DC Disconnect.

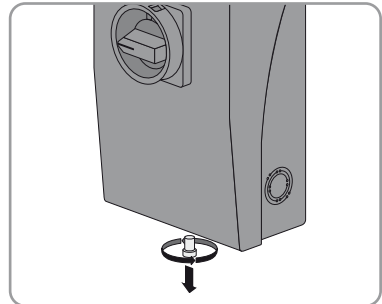

6. Snap out the required number of knockouts on the desired side of the DC Disconnect for the installation of the conduit fittings (diameter $\frac{1}{2}$ in., $\frac{3}{4}$ in. or 1 in.).

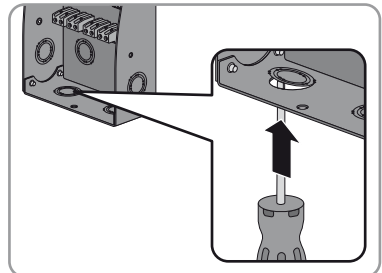

7. **NOTICE****Damage to the DC Disconnect due to enlarged knockouts**

Enlarged knockouts enable moisture to penetrate the DC Disconnect which could damage electronic components in the DC Disconnect.

- Do not enlarge the knockouts.

8. Connect the connection cable of the inverter in the DC Disconnect. Use a flat-blade screwdriver (blade width 5 mm) for this (torque 15 in-lb. (1.7 Nm)).

- Insert the red cable into the **RD** screw terminal and tighten the terminal.
- Insert the orange cable into the **OR** screw terminal and tighten the terminal.
- Insert the black cable into the **BK** screw terminal and tighten the terminal.

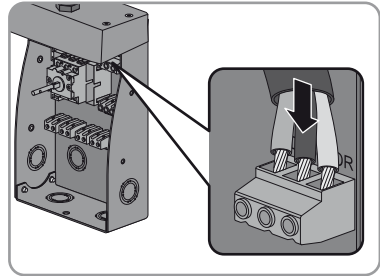

9. Install conduits with conduit fittings in the enclosure openings on the DC Disconnect.
10. Feed the DC cables of the PV strings and the DC equipment grounding conductors through the conduits into the DC Disconnect.
11. Strip the insulation of the insulated conductors by a length of $\frac{1}{2}$ in. (12 mm).
12. Insert the equipment grounding conductor of the PV array into the grounding terminal in the DC Disconnect and tighten the terminals using a flat-blade screwdriver (blade width: 5 mm) (torque: 15 in-lb (1.7 Nm)).

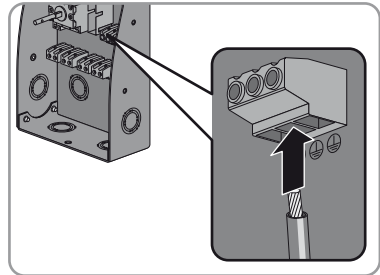

13. Check the PV array for ground faults (see Section 11.5 "Checking the PV System for Ground Faults", page 73).

14. Connect the first string for input A to the terminal blocks for input **A**. Use a flat-blade screwdriver (blade width: 5 mm) for this (torque: 15 in-lb. (1.7 Nm)).

- Insert the cable DC+ into the screw terminal + and tighten the terminal. Ensure the correct polarity when doing so.
- Insert the cable DC – into the screw terminal – and tighten the terminal. Ensure the correct polarity when doing so.

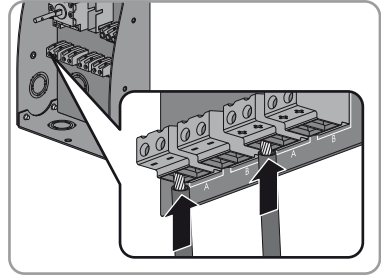

15. If there is another string for input A, connect it in the same way to the terminal blocks for input **A**.

16. Connect the first string for input B to the terminal blocks for input **B**. Use a flat-blade screwdriver (blade width: 5 mm) for this (torque: 15 in-lb. (1.7 Nm)).

- Insert the cable DC+ into the screw terminal + and tighten the terminal. Ensure the correct polarity when doing so.
- Insert the cable DC – into the screw terminal – and tighten the terminal. Ensure the correct polarity when doing so.

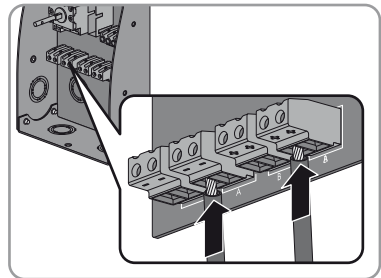

17. If there is another string for input B, connect it in the same way to the terminal blocks for input **B**.

18. Ensure that all screw terminals are correctly connected and that the cables are securely positioned in the screw terminals

19. Turn the rotary switch of the DC Disconnect to the **Off** position.

20. Push the DC Disconnect lid diagonally under the upper edge of the enclosure and press the lid down. The lid must be flush with the enclosure edge.

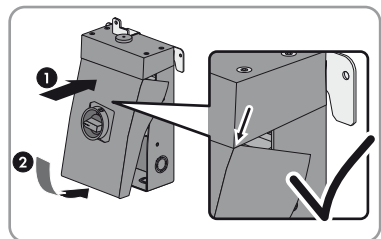

- 21. Tighten the lid of the DC Disconnect using an Allen key (AF 4) and the corresponding screw and conical spring washer (torque : 44 in-lb. (5 Nm)).

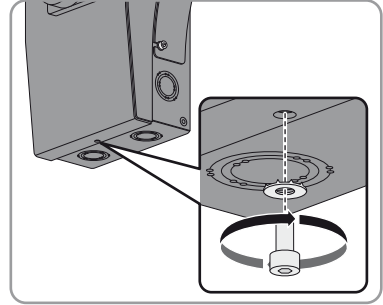

6.5 Connecting the Secure Power Supply Module

Circuit Diagram

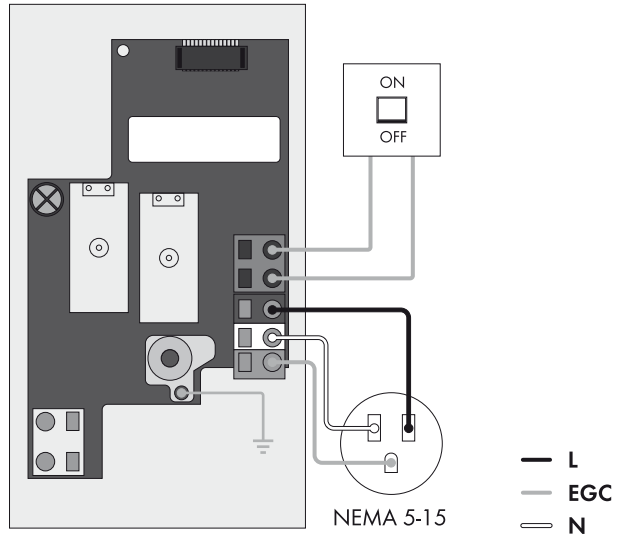

Additionally required mounting material (not included in the scope of delivery):

- Outlet for secure power supply operation
- Switch to activate the secure power outlet that is designed for at least 120 V (AC) and 10 A
- 1 conduit fitting ($\frac{3}{4}$ in. (19 mm)), rain-tight or for wet locations when installed outdoors
- 1 conduit ($\frac{3}{4}$ in. (19 mm))

Switch and outlet requirements

- The switch must be designed for at least 120 V AC and 10 A.
- When using pre-assembled switch-outlet combinations, switch and outlet must not be connected to each other. If they are connected, disconnect them.

i No Integrated Ground-Fault Circuit Interrupter (GFCI) for Outlet

The inverter is not equipped with a GFCI for the outlet. If a GFCI protection is desired, you must use an outlet with integrated GFCI.

Cable Requirements

- 5 insulated conductors for input switch, output switch, line conductor, neutral conductor and equipment grounding conductor (EGC) must be available.
- To avoid confusion, the colors of the cables for switch and outlet should be different.
- Solid or stranded wire of copper with no more than 19 single wires
- Conductor cross-section: 16 AWG to 12 AWG (1.3 mm² to 3.3 mm²)

Procedure

1. If the inverter is in operation, disconnect it (see Section 10).
2. Loosen the screw on the display and flip the display up until it clicks into place.

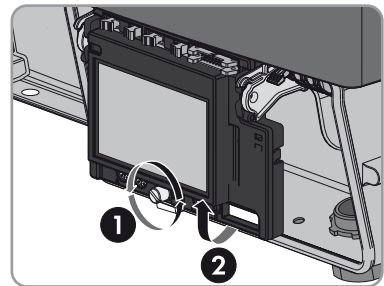

- Remove the filler plugs from the enclosure opening in the inverter.

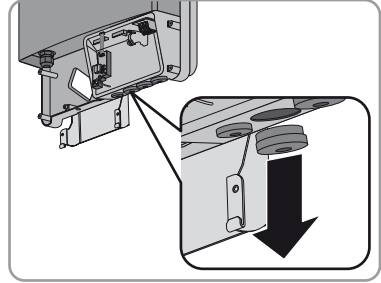

- Install the conduit with conduit fitting in the enclosure opening.
- Feed the cable through the conduit to the terminals on the SPS module.
- Strip $1\frac{1}{32}$ in. (9 mm) off the conductor insulation.

7. **⚠ WARNING**

Danger of fire due to short circuit

A short circuit can occur in the secure power supply operation if the insulated conductors of the outlet and the switch have been swapped. The short circuit can cause a fire in the switch.

- Insert the insulated conductors for connecting the switch into the black terminals.
- Insert the insulated conductors for connecting the outlet into the three-colored terminals.

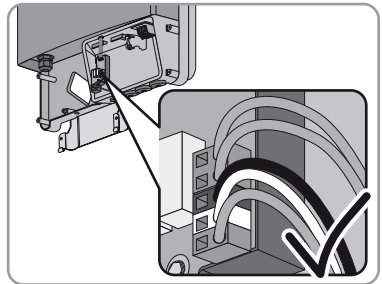

- Ensure that the grounding cable of the module is connected to the ground connection in the inverter.

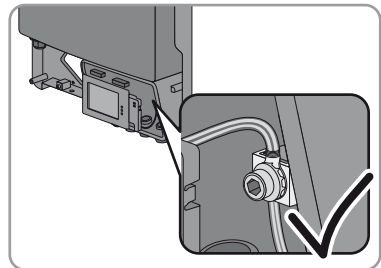

- Secure the conduit fitting from the inside using the counter nut.
- Connect the insulated conductors that are connected to the three-colored terminals of the SPS module to the outlet.

11. Connect the insulated conductors that are connected to the black terminals of the SPS module to the switch.
12. Attach the supplied warning label to the secure power outlet.
13. Label the switch using the supplied label. Label the closed switch position with "ON" and the opened switch position with "OFF".

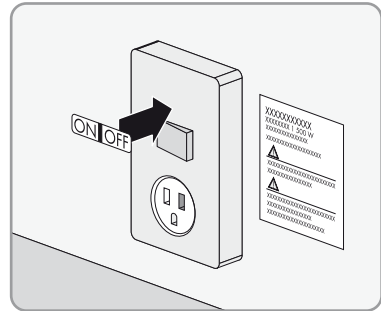

Information on the use of the outlet

You will find further information on the use of the outlet and on the connection conditions in the user manual supplied. Please inform the PV system operator.

7 Commissioning

7.1 Making Settings via the Rotary Switches

7.1.1 Overview of the Rotary Switches

The inverter can be configured for different countries and for use in backup and off-grid systems via two rotary switches. The rotary switches can also be used to change the display language.

By default, the inverter is set to a specific country data set. You can see which country data set was set as default at the factory in the supplementary sheet provided with the factory settings. If the default country data set of the inverter does not apply to your country, you must change the country data set and the display language. You can also change the display language independent of the country data set (see Section 7.1.3).

If you use a communication product, you can also change the country data set after commissioning using that communication product (see Section 8.1).

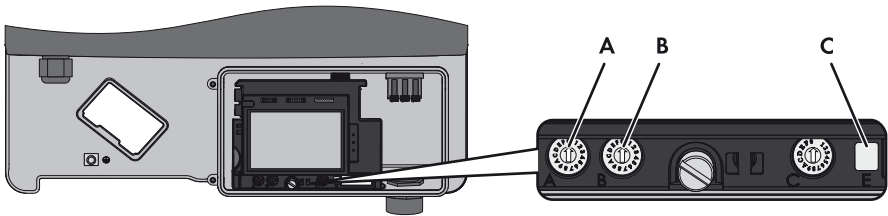

Figure 13: Configuration area inside the inverter

Item	Description
A	Rotary switch A for setting the country standard
B	Rotary switch B for setting the language
C	Jumper slot for setting the language to English

Possible Settings of the Rotary Switches

Here, you will find a list of possible rotary switch positions and which country data sets and display languages are represented by each position.

Each country data set contains various operating parameters, which can be individually set according to each country data set. The operating parameters can be read out using a communication product.

Rotary switch A position	Rotary switch B position	Country data set	Display language
0	0	Default settings	Default settings
0	1	Retained	English
0	2	Retained	German
0	3	Retained	French
0	4	Retained	Spanish
0	5	Retained	Italian
0	6	Retained	Greek
0	7	Retained	Czech
0	8	Retained	Korean
0	9	Retained	Portuguese
0	A	Retained	Dutch
0	B	Retained	Slovenian
0	C	Retained	Bulgarian
0	D	Retained	Polish
9	8	UL1741 *	English
9	9	UL1741 *	Spanish
9	A	UL1741 *	French
C	0	Other standard	English
C	1	Other standard	German
C	2	Other standard	French
C	3	Other standard	Spanish
C	4	Other standard	Italian
C	5	Other standard	Greek
C	6	Other standard	Czech
D	0	Island mode 60 Hz	English
D	1	Island mode 60 Hz	German

Rotary switch A position	Rotary switch B position	Country data set	Display language
D	2	Island mode 60 Hz	French
D	3	Island mode 60 Hz	Spanish
D	4	Island mode 60 Hz	Italian
D	5	Island mode 60 Hz	Greek
D	6	Island mode 60 Hz	Czech
E	0	Island mode 50 Hz	English
E	1	Island mode 50 Hz	German
E	2	Island mode 50 Hz	French
E	3	Island mode 50 Hz	Spanish
E	4	Island mode 50 Hz	Italian
E	5	Island mode 50 Hz	Greek
E	6	Island mode 50 Hz	Czech

* The country data set is automatically blocked after ten feed-in hours. Then you can only change the country data set by entering the personal access code you received from SMA on a communication device.

7.1.2 Changing the Country Data Set and the Display Language

If the default country data set of the inverter does not apply to your country, you must change the country data set and the display language.

1. If the inverter is in operation, disconnect it (see Section 10).
2. Set the rotary switches **A** and **B** to the desired position using a flat-blade screwdriver (blade width: 2.5 mm) (see Section 7.1.1 "Overview of the Rotary Switches", page 47).

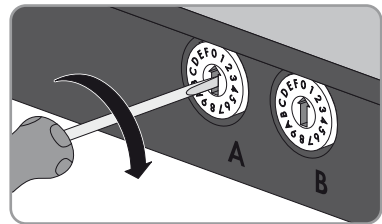

3. Commission the inverter (see Section 7.2).
 - The inverter will adopt the setting after commissioning. This can take up to 5 minutes.

7.1.3 Changing the Display Language

You can change the display language independent of the country data set. This ensures that the country data set remains unchanged.

Hint: If you simply remove the jumper, the display language automatically changes to English.

1. If the inverter is in operation, disconnect it (see Section 10).
2. Set the rotary switch **A** to **O** using a slotted screwdriver (blade width: 2.5 mm). This ensures that the country data set remains unchanged.

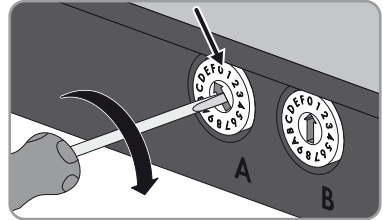

3. Set the rotary switch **B** to the desired language using a slotted screwdriver (blade width: 2.5 mm) (see Section 7.1.1 "Overview of the Rotary Switches", page 47).

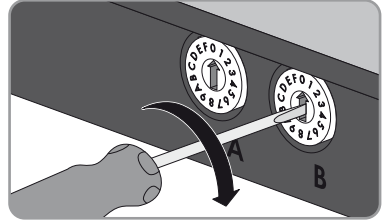

4. Commission the inverter (see Section 7.2).
- The inverter will adopt the setting after commissioning. This can take up to 5 minutes.

7.2 Commissioning the Inverter

Requirements:

- AC overcurrent protection and AC disconnecting unit must be correctly designed.
- The inverter must be correctly mounted and closed.
- The DC Disconnect must be correctly mounted and closed.
- All cables must be correctly connected.

1. Place the lower enclosure lid with the 6 screws onto the enclosure and tighten them using an Allen key (AF 3) in the order 1 to 6 (torque: 18 in-lbs. (2.0 Nm).

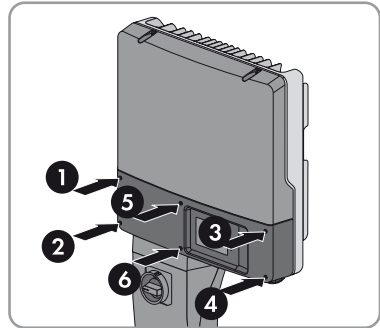

2. Switch on or close all AC disconnecting switches and circuit breakers in the output circuit of the inverter.
 3. If an external DC disconnecting switch is available, switch on or close the DC disconnecting switch.
 4. Turn the rotary switch of the DC Disconnect to the **On** position.
- The inverter carries out an arc-fault circuit interrupter (AFCI) self test.
 - The green LED is lit and the display shows the device type, the firmware version, the device names, the country data set and display language. If communication is via Speedwire, then the status and the versions of the communication assemblies will also be displayed also after the device names.

The inverter feeds into the grid.

✘ Green LED flashing?

Possible cause of error: The DC input voltage is still too low, or the inverter is monitoring the utility grid.

- Once the DC input voltage is sufficiently high, the inverter goes into operation.

✘ The red LED is lit and an error message and event number appear in the display?

- Eliminate the error (see Section 1.1 "Troubleshooting", page 59).

✘ The blue LED is glowing or flashing?

- Eliminate the communication error (see Section 9.3 "LED Signals", page 54).

8 Configuration

8.1 Changing the Country Data Set Using a Communication Product

By default, the inverter is set to a specific country data set. You can see which country data set was set by default at the factory on the type label and the supplementary sheet with the default settings provided. If the default country data set of the inverter does not apply to your country or you want to use the inverter in a backup or off-grid system, then you must change the country data set.

Requirements:

- A communication product that is appropriate for the type of communication used must be available.
 - The responsible grid operator must approve changes of grid-relevant parameters.
 - An SMA Grid Guard code for changing the grid-relevant parameters must be available (for application for the SMA Grid Guard code, see certificate "Application for SMA Grid Guard Code" at www.SMA-Solar.com).
1. Access the user interface of the communication product.
 2. Enter the SMA Grid Guard code.
 3. Select the **CntrySet** or **Set country standard** parameter and set the required country data set.
 4. Save setting.

8.2 Activating and Setting SMA OptiTrac Global Peak

With partially shaded PV modules, you should activate SMA OptiTrac Global Peak and set the time interval in which the inverter will optimize the MPP of the PV system.

Requirement:

- A communication product that is appropriate for the type of communication used must be available.

Procedure:

1. Log in to the communication product as **Installer**.
2. Select the parameter **MPPShdw.IsOn/OptiTrac Global Peak switched on** and set to **On**.
3. Select the parameter **MPPShdw.CycTms/Cycle time of the OptiTrac Global Peak algorithm** and set the required time interval. Hint: The ideal time interval is normally six minutes. This value should only be increased if the shading situation changes extremely slowly.
 - The inverter optimizes the MPP of the PV system at the specified time interval.

9 Display and LEDs

9.1 Switching On the Display

By tapping on the enclosure lid once you can operate the display as follows:

- Switch on the display
- Switch through the text line display
- Switch between the power curve of the last 16 feed-in hours and the energy yields of the last 16 days

9.2 Calling Up Messages of the Start Phase

If you double tap on the enclosure lid, the display messages of the start phase are repeated. The following device properties will be displayed in succession:

- Device type
- Firmware version
- Serial number or device name of the inverter
- For Speedwire communication: version information of the assembly
- Country data set used
- Display language

9.3 LED Signals

The LEDs indicate the operating state of the inverter.

LED	Status	Explanation
Green	is glowing	Operation If an event occurs, the event message is shown in the display (see Section 11.1).
	is flashing	Conditions for connection to the grid are not fulfilled.
	is flashing quickly	The inverter is performing an update.
Red	is glowing	Error The display shows the error message and event number (see Section 11.2).
Blue	is glowing	Data transmission active The inverter has set up a connection to a communication product and data transmission is active.

i All LEDs have gone out

If all three LEDs have gone out, the inverter is switched off because the switch of the DC Disconnect is set to **Off** or insufficient irradiation is available.

- Set the switch of the DC Disconnect to **On**.

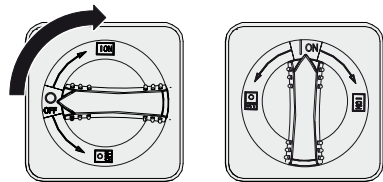

10 Disconnecting the Inverter from Voltage Sources

⚠ DANGER

Danger to life due to high voltages in the inverter

Death or serious injury due to electric shock.

- Only open the inverter in the order described here.
- Before performing any tasks, wait five minutes until the residual voltage has been drained from the components.

NOTICE

Damage to the seal of the enclosure lid during sub-zero conditions

When opening the enclosure lid during sub-zero conditions, the seal of the enclosure lid can be damaged. There may be an ingress of moisture, which can damage the inverter.

- Do not open the inverter when the outside temperature is below 23°F (- 5°C).

1. Switch off or open all AC disconnecting switches and circuit breakers in the output circuit of the inverter and secure against reconnection.
2. If an external DC disconnecting switch is available, switch off or open the DC disconnecting switch.
3. Turn the rotary switch of the DC Disconnect to **Off**.

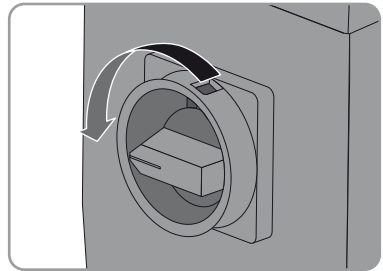

4. Wait until the LEDs and display switch off.
5. Remove all six screws of the lower enclosure lid using an Allen key (AF 3) and remove the enclosure lid.

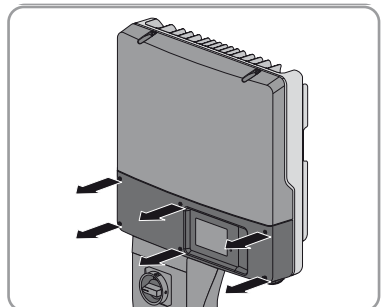

6. **NOTICE****Damage to the inverter due to electrostatic discharge**

The internal components of the inverter can be irreparably damaged by electrostatic discharge.

- Ground yourself before touching any components.
7. Ensure that no voltage is present on the AC connecting terminal plate using a suitable measuring device. Insert the test probe in each round opening of the terminal:
- Ensure that no voltage is present between L1 and N.
 - Ensure that no voltage is present between L1 and the equipment grounding conductor.
 - Ensure that no voltage is present between L2 and N.

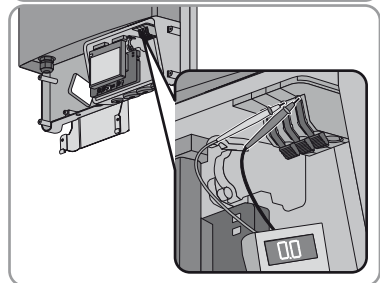
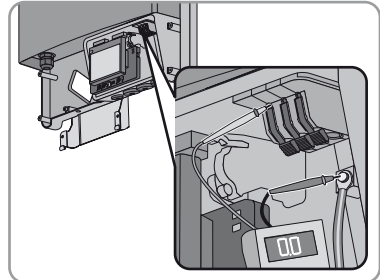
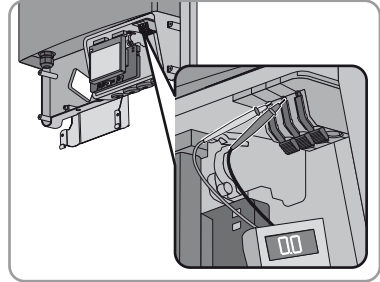

- Ensure that no voltage is present between L2 and the equipment grounding conductor.

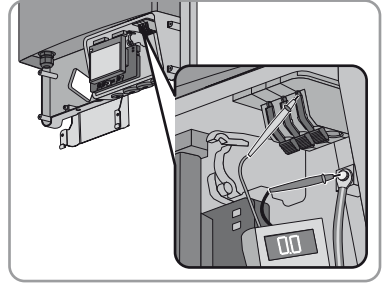

10.1 Disconnecting the DC Disconnect from Voltage Sources

1. Turn the rotary switch of the DC Disconnect to **Off**.

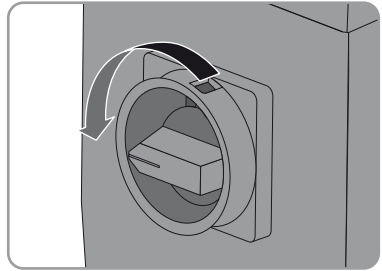

2. Wait until the LEDs and inverter display switch off.
3. Loosen the screw on the lower side of the DC Disconnect using an Allen key (AF 4) and remove the lid of the DC Disconnect.

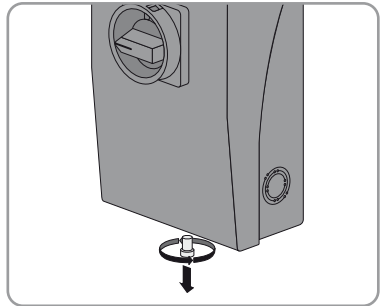

4. If an external DC disconnecting switch is available, open the DC disconnecting switch.
5. If there is no external DC disconnecting switch available, cover the PV modules with opaque material or disconnect the connectors on the PV modules.

6. **⚠ DANGER****Danger to life due to electric shock when touching the DC conductors and DC terminals**

High voltages are present in the DC cables and DC terminals.

- Before performing any tasks, wait five minutes until the residual voltage has been drained.
 - Do not touch the DC conductors and DC terminals.
7. Ensure that no voltage is present on the DC terminals using a suitable measuring device. Insert the test probe in each round opening of the terminal.

11 Troubleshooting

11.1 Event Messages

Display message	Cause
AFCI self-test successful	The inverter has successfully performed the arc fault detection self-test.
Backup mode on	The inverter is operating in grid parallel operation with adjusted grid monitoring.
Grid guard code valid	The SMA Grid Guard code entered is valid. Protected parameters have now been unblocked and you can adjust the parameters. The parameters will be automatically locked again after 10 feed-in hours.
No new update SDcard	There are no update files relevant for this inverter on the SD card or the available update has already been carried out.
Grid param.unchanged	The selected rotary switch position is not assigned or it is not possible to change the grid parameters.
Parameters set successfully	A new country data set has been configured.
SD card is read	The inverter is currently reading the SD card.
Self-test	The self-test is being carried out.
Set parameter	The inverter is setting the parameters.
Standalone op.	The inverter is operating in the secure power supply operation.
Update completed	The inverter has successfully completed the update.
Update main CPU	The inverter is performing an update of the inverter components.
Update communication	The inverter is performing an update of the communications components.
Update RS485I module	The inverter is updating the RS485i module.
Update Speedwire	The inverter is updating the Speedwire module.
Upd. language table	The inverter is updating the language table.
Update Webconnect	The inverter is updating the Webconnect module.
Update file OK	The update file found is valid.

11.2 Error Messages

Event number	Display message	Cause and corrective measures
101 to 103	Grid fault	<p>The line voltage or grid impedance at the connection point of the inverter is too high. The inverter has disconnected from the utility grid.</p> <p>Corrective measures:</p> <ul style="list-style-type: none"> • Check whether the line voltage at the connection point of the inverter is permanently in the permissible range. <p>If the line voltage is outside the permissible range due to local grid conditions, contact the grid operator. Ask the grid operator whether the voltage can be adapted at the feed-in point or if it would be acceptable to change the monitored operating limits.</p> <p>If the line voltage is permanently in the permissible range and this message is still displayed, contact the SMA Service Line.</p>
202 to 205	Grid fault	<p>The utility grid has been disconnected, the AC cable is damaged or the line voltage at the connection point of the inverter is too low. The inverter has disconnected from the utility grid.</p> <p>Corrective measures:</p> <ul style="list-style-type: none"> • Ensure that the circuit breaker is switched on. • Ensure that the AC cable is not damaged. • Ensure that the AC cable is connected correctly. • Check whether the line voltage at the connection point of the inverter is permanently in the permissible range. <p>If the line voltage is outside the permissible range due to local grid conditions, contact the grid operator. Ask the grid operator whether the voltage can be adapted at the feed-in point or if it would be acceptable to change the monitored operating limits.</p> <p>If the line voltage is permanently in the permissible range and this message is still displayed, contact the SMA Service Line.</p>

Event number	Display message	Cause and corrective measures
301	Grid fault	<p>The 10-minute average line voltage is no longer within the permissible range. The line voltage or grid impedance at the connection point is too high. The inverter disconnects from the utility grid to comply with the power quality.</p> <p>Corrective measures:</p> <ul style="list-style-type: none"> • Check whether the line voltage at the connection point of the inverter is permanently in the permissible range. <p>If the line voltage is outside the permissible range due to local grid conditions, contact the grid operator. Ask the grid operator whether the voltage can be adapted at the feed-in point or if it would be acceptable to change the monitored operating limits.</p> <p>If the line voltage is permanently in the permissible range and this message is still displayed, contact the SMA Service Line.</p>
401 to 404	Grid fault	<p>The inverter is no longer in grid-parallel operation. The inverter has stopped feeding into the utility grid.</p> <p>Corrective measures:</p> <ul style="list-style-type: none"> • Check the grid connection for strong, short-term frequency variations.
501	Grid fault	<p>The power frequency is not within the permissible range. The inverter has disconnected from the utility grid.</p> <p>Corrective measures:</p> <ul style="list-style-type: none"> • If possible, check the power frequency and observe how often fluctuations occur. <p>If there is a high number of fluctuations and this message is displayed frequently, contact the grid operator and ask whether they approve a change of the operating parameters of the inverter.</p> <p>If the grid operator approves, discuss any changes to the operating parameters with the SMA Service Line.</p>

Event number	Display message	Cause and corrective measures
601	Grid fault	<p>The inverter has detected an excessively high proportion of direct current in the line current.</p> <p>Corrective measures:</p> <ul style="list-style-type: none"> • Check the grid connection for direct current. <p>If this message is displayed frequently, contact the grid operator and check whether it is possible to raise the limiting value for monitoring on the inverter.</p>
701	Frq. not permitted Check parameters	<p>The power frequency is not within the permissible range. The inverter has disconnected from the utility grid.</p> <p>Corrective measures:</p> <ul style="list-style-type: none"> • If possible, check the power frequency and observe how often fluctuations occur. <p>If there is a high number of fluctuations and this message is displayed frequently, contact the grid operator and ask whether they approve a change of the operating parameters of the inverter.</p> <p>If the grid operator approves, discuss any changes to the operating parameters with the SMA Service Line.</p>
801	Waiting for grid voltage Grid failure Check fuse	<p>There is no line voltage at the AC output of the inverter.</p> <p>Corrective measures:</p> <ul style="list-style-type: none"> • Check the fuse and replace it if necessary. • Check AC installation. • Check whether there is a general power outage.

Event number	Display message	Cause and corrective measures
1501	Reconnection fault grid	<p>The changed country data set or the value of a parameter you have set does not correspond to the local requirements. The inverter cannot connect to the utility grid.</p> <p>Corrective measures:</p> <ul style="list-style-type: none"> • Ensure that the country data set has been configured correctly. Check the setting of the rotary switches A and B or select the parameter Set country standard and check the value.
3301 to 3303	Unstable operation	<p>There is not enough power at the DC input of the inverter for stable operation. This may be caused by snow on the PV modules or insufficient irradiation. The inverter interrupts the feed-in operation.</p> <p>Corrective measures:</p> <ul style="list-style-type: none"> • Wait for higher irradiation. • If this event recurs at medium irradiation levels, check the PV system design and the correct circuitry of the PV array.
3401 to 3402	DC overvoltage Disconnect generator	<p>Overvoltage at the DC input. The inverter may be destroyed.</p> <p>When this message is signaled, it is accompanied by rapid flashing of the backlight.</p> <p>Corrective measures:</p> <ul style="list-style-type: none"> • IMMEDIATELY DISCONNECT the inverter from voltage sources (see Section 10). • Check whether the DC voltage is below the maximum system voltage of the inverter. If the DC voltage is below the maximum system voltage of the inverter, reconnect the DC connectors to the inverter. • If the DC voltage is above the maximum system voltage of the inverter, ensure that the PV array has been correctly rated or contact the PV array installer. • If this message is repeated frequently, contact the SMA Service Line.

Event number	Display message	Cause and corrective measures
3501	Insulation resist. Check generator	The inverter has detected a ground fault in the PV array. Corrective measures: <ul style="list-style-type: none"> • Check the PV system for ground faults (see Section 11.5).
3601	High discharge curr. Check generator	The leakage current from the inverter and the PV array is too high. A ground fault, a residual current or a malfunction is present. The inverter interrupts feed-in operation immediately after exceeding a limiting value and then automatically re-connects to the utility grid. Corrective measures: <ul style="list-style-type: none"> • Check the PV system for ground faults (see Section 11.5).
3701	Resid.curr.too.high Check generator	The inverter has detected a residual current through brief PV array grounding. Corrective measures: <ul style="list-style-type: none"> • Check the PV system for ground faults (see Section 11.5).
3801 to 3802	DC overcurrent Check generator	The inverter switches off due to an overcurrent on the DC side. Corrective measures: If this event occurs frequently: <ul style="list-style-type: none"> • Check the design and circuitry of the PV array.
3901 to 3902	Waiting for DC start conditions Start cond. not met	The input power or the input voltage of the PV modules is insufficient for utility grid feed-in. Corrective measures: <ul style="list-style-type: none"> • Wait for higher irradiation. • If this event recurs at medium irradiation levels, check the PV system design and the correct circuitry of the PV array.
4301	Electr. arc detected Check generator	The inverter has detected an electric arc. Corrective measures: <ul style="list-style-type: none"> • See Section 11.7 for troubleshooting.

Event number	Display message	Cause and corrective measures
6001 to 6009	Self diagnosis Interference device	The cause must be determined by the SMA Service Line. Corrective measures: <ul style="list-style-type: none"> • Contact the SMA Service Line.
6101 to 6112	Self diagnosis Interference device	The cause must be determined by the SMA Service Line. Corrective measures: <ul style="list-style-type: none"> • Contact the SMA Service Line.
6202	Self diagnosis Interference device	The cause must be determined by the SMA Service Line. Corrective measures: <ul style="list-style-type: none"> • Contact the SMA Service Line.
6301 to 6314	Self diagnosis Interference device	The cause must be determined by the SMA Service Line. Corrective measures: <ul style="list-style-type: none"> • Contact the SMA Service Line.
6401 to 6438	Self diagnosis Interference device	The cause must be determined by the SMA Service Line. Corrective measures: <ul style="list-style-type: none"> • Contact the SMA Service Line.
6501 to 6502	Self diagnosis Overtemperature	The inverter has switched off due to excessive temperatures. Corrective measures: <ul style="list-style-type: none"> • Clean the cooling fins and air ducts (see Section 11.3). • Ensure that the inverter has sufficient ventilation.
6603 to 6604	Self diagnosis Overload	The cause must be determined by the SMA Service Line. Corrective measures: <ul style="list-style-type: none"> • Contact the SMA Service Line.

Event number	Display message	Cause and corrective measures
6701 to 6702	Comm. disturbed	<p>A fault has occurred in the internal communication of the inverter. The inverter continues feeding power into the grid.</p> <p>Corrective measures:</p> <p>If this event occurs frequently:</p> <ul style="list-style-type: none"> • Contact the SMA Service Line.
6801 to 6802	Self diagnosis Input A defective	<p>Inverter input A is defective.</p> <p>Corrective measures:</p> <ul style="list-style-type: none"> • Contact the SMA Service Line.
6901 to 6902	Self diagnosis Input B defective	<p>Inverter input B is defective.</p> <p>Corrective measures:</p> <ul style="list-style-type: none"> • Contact the SMA Service Line.
7001 to 7002	Sensor fault	<p>A temperature sensor in the inverter is faulty. The inverter interrupts the feed-in operation.</p> <p>Corrective measures:</p> <ul style="list-style-type: none"> • Contact the SMA Service Line.
7008	Disturbance sensor display temperature	<p>The ambient temperature sensor is faulty. The display is not switched off at temperatures below -13 °F (-25 °C) and as a result may have been destroyed. The inverter continues feeding power into the grid.</p> <p>Corrective measures:</p> <ul style="list-style-type: none"> • Contact the SMA Service Line.
7101	SD card defective	<p>The SD card is not formatted correctly or is defective. The update failed. The inverter continues feeding power into the grid.</p> <p>Corrective measures:</p> <ul style="list-style-type: none"> • Re-format the SD card. • Re-save the files to the SD card.
7102	Parameter file not found or defective	<p>The parameter file was not found or is defective. The update failed. The inverter continues feeding power into the grid.</p> <p>Corrective measures:</p> <ul style="list-style-type: none"> • Copy the parameter file into the SD card drive:\PARASET directory.

Event number	Display message	Cause and corrective measures
7105	Param. setting failed	Parameters cannot be set via the SD card. The inverter continues feeding power into the grid. Corrective measures: <ul style="list-style-type: none"> • Check the parameters for valid values. • Ensure change rights via SMA Grid Guard code.
7106	Update file defect.	The update file is defective. The update failed. The inverter continues feeding power into the grid. Corrective measures: <ul style="list-style-type: none"> • Re-format the SD card. • Re-save the files to the SD card.
7110	No update file found	No new update file was found on the SD card. The update failed. The inverter continues feeding power into the grid. Corrective measures: <ul style="list-style-type: none"> • Copy the update file into the SD card drive:\UPDATE directory.
7201 to 7202	Data stor. not poss.	Internal device fault, the inverter continues feeding power into the grid. Corrective measures: <ul style="list-style-type: none"> • If this error occurs frequently, contact the SMA Service Line.
7303	Update main CPU failed	Internal device fault. The inverter continues feeding power into the grid. In very rare cases, the firmware is damaged and the inverter interrupts the feed-in. Corrective measures: <ul style="list-style-type: none"> • Contact the SMA Service Line.
7305	Update RS485I module failed	Internal device fault, the inverter continues feeding power into the grid. Corrective measures: <ul style="list-style-type: none"> • Re-try update. • If this error occurs again, contact the SMA Service Line.

Event number	Display message	Cause and corrective measures
7311	Update language table failed	<p>Internal device fault, the inverter continues feeding power into the grid.</p> <p>Corrective measures:</p> <ul style="list-style-type: none"> • Re-try update. • If this error occurs again, contact the SMA Service Line.
7316	Update Speedwire module failed	<p>Internal device fault, the inverter continues feeding power into the grid.</p> <p>Corrective measures:</p> <ul style="list-style-type: none"> • Re-try update. • If this error occurs again, contact the SMA Service Line.
7326	Webconnect update unsuccessful	<p>Internal device fault, the inverter continues feeding power into the grid.</p> <p>Corrective measures:</p> <ul style="list-style-type: none"> • Re-try update. • If this error occurs again, contact the SMA Service Line.
7508	External fan fault	<p>The fan is contaminated or defective. The inverter may reduce its power due to overheating. The inverter continues feeding power into the grid.</p> <p>Corrective measures:</p> <ul style="list-style-type: none"> • Clean the fan • Replace the fan.
7701 to 7712	Self diagnosis Interference device	<p>The cause must be determined by the SMA Service Line.</p> <p>Corrective measures:</p> <ul style="list-style-type: none"> • Contact the SMA Service Line.

Event number	Display message	Cause and corrective measures
8001	Derating occurred	<p>The inverter has reduced its power output for more than ten minutes due to excessive temperature.</p> <p>Corrective measures:</p> <ul style="list-style-type: none"> • If this message is frequently displayed, clean the cooling fins and air ducts (see Section 11.3 "Cleaning the Inverter", page 71). • Ensure that the inverter has sufficient ventilation.
8101 to 8104	Comm. disturbed	<p>The cause must be determined by the SMA Service Line.</p> <p>Corrective measures:</p> <ul style="list-style-type: none"> • Contact the SMA Service Line.
8204	AFCI self-test failed	<p>The cause must be determined by the SMA Service Line.</p> <p>Corrective measures:</p> <ul style="list-style-type: none"> • Contact the SMA Service Line.
8206	Electr. arc detected Please confirm by tapping	<p>The inverter has detected an electric arc and was recommissioned after a disconnection. By tapping, you are confirming that you have repaired any possible damage to PV modules, cables or plugs in the PV system.</p> <p>Corrective measures:</p> <ul style="list-style-type: none"> • Tap on the display within ten seconds of the display message appearing in order to recommission the inverter.

Event number	Display message	Cause and corrective measures
8801 to 8803	No display	<p>This error message can have 3 causes but the inverter continues to feed into the utility grid.</p> <p>The ambient temperature is lower than - 13 °F (-25 °C). The display switched off for protection.</p> <p>The inverter cannot identify the display type.</p> <p>No display is connected to the inverter or the connection is defective.</p> <p>Corrective measures:</p> <ul style="list-style-type: none"> • If the display switched off due to the ambient temperature being too low, wait until the ambient temperature is above - 13 °F (-25 °C). • If the ambient temperature is above - 13 °F (-25 °C), contact the SMA Service Line.
9002	Grid guard code invalid	<p>The SMA Grid Guard code entered is incorrect. The parameters are still protected and cannot be changed.</p> <p>Corrective measures:</p> <ul style="list-style-type: none"> • Enter the correct SMA Grid Guard code.
9003	Grid param. locked	<p>The parameters are now locked. The parameters cannot be changed.</p> <p>Corrective measures:</p> <ul style="list-style-type: none"> • Unlock the parameters with the SMA Grid Guard code.

Event number	Display message	Cause and corrective measures
9005	Changing grid param. not possible Ensure DC supply	This error can have the following causes: <ul style="list-style-type: none"> • The selected rotary switch setting for the country configuration is not programmed. • The parameters to be changed are protected. • The DC voltage at the DC input is not sufficient to run the main CPU. <p>Corrective measures:</p> <ul style="list-style-type: none"> • Check the settings of the rotary switches (see Section 7.1.2 "Changing the Country Data Set and the Display Language", page 49). • Enter the SMA Grid Guard code. • Ensure sufficient DC voltage (green LED lights up or flashes).

11.3 Cleaning the Inverter

NOTICE

Damage to the display due to the use of cleaning agents

- If the inverter is dirty, clean the enclosure lid, the display, and the LEDs using only clean water and a cloth.
- If the cooling fins on the rear of the enclosure are dirty, clean them with a soft brush.
- If the air ducts on the top of the inverter are dirty, clean them with a soft brush.

11.4 Cleaning the Fan

The SB 6000TL-US is equipped with a fan as standard. You can dismantle the fan for cleaning, as described in the following sections.

Disassembling the Fan

1. Disconnect the inverter from any voltage sources (see Section 10 "Disconnecting the Inverter from Voltage Sources", page 55).
2. Loosen the screws of the lower enclosure lid and remove the enclosure lid.
3. Wait for the fan to stop rotating.

- Loosen the screw on the display and flip the display up until it clicks into place.

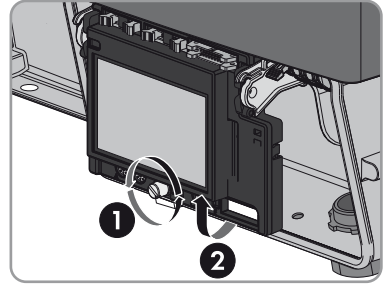

- Push both detents of the fan casing towards the fan and remove the fan along with the fan casing.

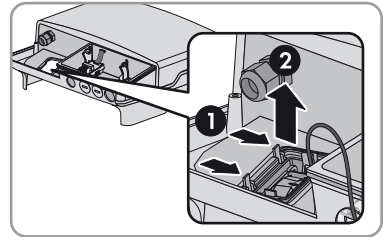

Cleaning the Fan

- Remove the fan and clean it with a soft brush, a paint brush or a cloth and water.

NOTICE

Damage to the fan through use of compressed air

- Do not use compressed air to clean it. This could damage the fan.

Inserting the Fan

- Insert the fan with fan casing into the enclosure opening. The arrow on the fan casing must point towards the display.

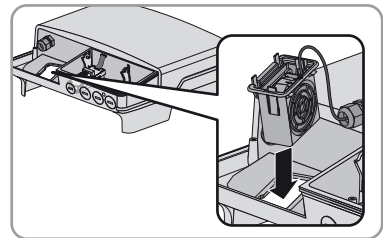

- Hook the detents on the right-hand side of the fan casing underneath the wall of the enclosure and press the fan with fan casing into the enclosure opening.
 - The left-hand detents snap into place.

9. Flip the display down and fasten the screw hand-tight.

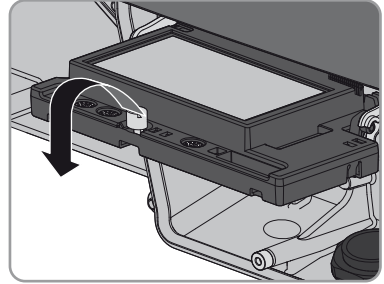

10. Close the inverter and recommission it (see the inverter installation manual).

11.5 Checking the PV System for Ground Faults

If the inverter displays the event numbers 3501, 3601 or 3701, there could be a ground fault. The electrical insulation between the PV system to ground is defective or insufficient.

⚠ WARNING

Danger to life due to electric shock

In the event of a ground fault, high voltages can be present in the PV module construction.

- Only touch the cables of the PV modules on their insulation.
- Do not connect DC cables with ground faults to the inverter.

Proceed as follows to check each string in the PV system for ground faults.

1. Disconnect the inverter from any voltage sources (see Section 10).
2. Measure voltages:
 - Measure the voltages between the positive terminal and the ground potential.
 - Measure the voltages between the negative terminal and the ground potential.
 - Measure the voltages between the positive terminals and negative terminals.

If the following results are returned simultaneously, there is a ground fault in the PV system.

 - All measured voltages are stable.
 - The sum of the two voltages against the ground potential is approximately equal to the voltage between the positive and negative terminals.
3. Determine the location of the ground fault via the ratio of the two measured voltages.

Example: location of the ground fault

The example shows a ground fault between the second and third PV modules.

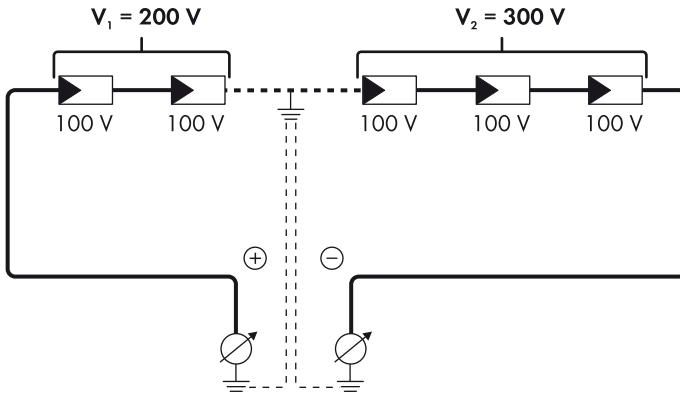

4. Eliminate the ground fault.
5. Commission the inverter (see Section 7.2).
6. If there is no ground fault and the message continues to be displayed, contact the SMA Service Line.

11.6 Replacing DC Varistors

In regions where electrical storms or other DC overvoltages frequently occur, the DC varistors lose their functionality if the PV system is not equipped with additional overvoltage protection. In such cases, SMA recommends replacing DC varistors with new ones after an operating period of 10 years in order to ensure that the functionality of the DC varistors remains at a constant level.

Order new varistors directly from SMA (for order numbers, see Page 89).

NOTICE

Damage to the inverter due to overvoltage

If varistors are missing, the inverter is no longer protected against overvoltage.

- Do not operate the inverter without varistors in plants with a high risk of overvoltages.
- Only recommission the inverter after you have replaced the defective varistors.

1. Disconnect the inverter and the DC Disconnect from voltage sources (see Section 10).

2. Insert the insertion tool into the contacts of the connecting terminal plate.

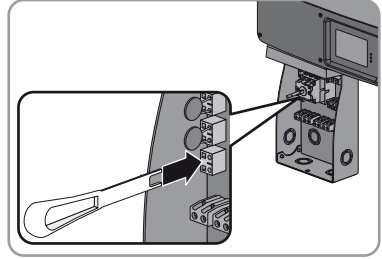

3. Remove the varistor from the connecting terminal plate.

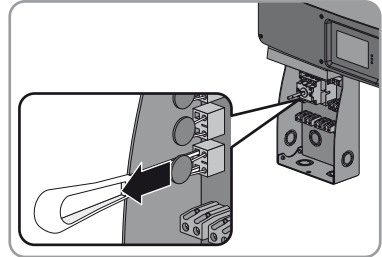

4. Insert the new varistor into the terminal. The labels of the varistor must face to the right at the inside of the inverter.

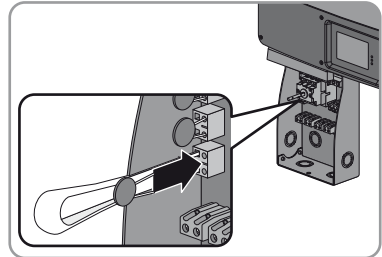

5. Ensure that the wires of the varistors are secure in the terminal.
6. Remove the insertion tool from the contacts of the connecting terminal plate.
7. Push the DC Disconnect lid diagonally under the upper edge of the enclosure and press the lid down. The lid must be flush with the enclosure edge.

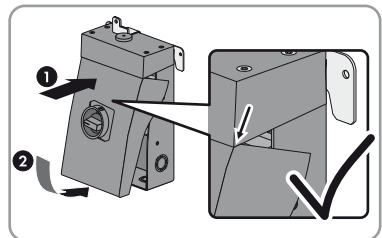

8. Tighten the lid of the DC Disconnect using an Allen key (AF 4) and the corresponding screw and conical spring washer (torque : 44 in-lb. (5 Nm)).

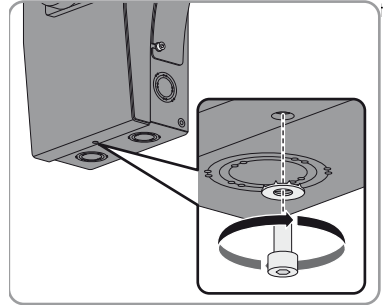

9. Commission the inverter (see Section 7.2).

11.7 The Message "Electr. arc detected" is displayed

- ✘ An electric arc occurred in the PV system.
- ✘ The red LED is permanently lit.
- ✘ The AFCI has tripped and the inverter is in permanent shutdown.

CAUTION

Danger of fire from electric arc

- Only test the AFCI for false tripping in the order described below.
- Do not deactivate the AFCI permanently.

1. Disconnect the inverter from voltage sources (see Section 10).
2. Perform troubleshooting in the PV system:
Check all PV strings for the correct open-circuit voltage.
3. After the fault is rectified, restart the inverter (see Section 7.2).
 The inverter starts and performs another AFCI self-test.
4. If the following message appears on the display, tap on the enclosure lid: **Electr. arc detected.**
Please confirm by tapping.



The message "Electr. arc detected. Please confirm by tapping." appears for **10 seconds only. After this, it is no longer possible to restart the unit by tapping on the enclosure lid.**

- To restart the system, repeat step 1 to step 3.

or

- Access the user interface of the communication product.

- Reset the operation inhibition by setting one of the following parameters:

Select the parameter **Reset operating data** or **Op.FncSetIstl** and set to **Reset operation inhibition** or **RSPermStopOp**. This effects resetting of the operation inhibition.

or

Select the parameter **AFCI switched on** or **AfcilsOn** and set to **No** and then back to **Yes**. This effects resetting of the operation inhibition.

- ☑ If the AFCI self-test is successful, the green LED is lit and the display shows the device type, the firmware version, the device names, the country data set and display language. If communication is Speedwire, then the status and the versions of the communication assemblies will also be displayed also after the device names.

The inverter feeds into the grid.

- ✘ Green LED flashing?
 - Possible cause of error: The DC input voltage is still too low, or the inverter is monitoring the utility grid.
 - Once the DC input voltage is sufficiently high, the inverter goes into operation.
- ✘ The red LED is lit and an error message and event number appear in the display?
 - Eliminate the error (see Section 11 "Troubleshooting", page 59).
- ✘ The blue LED is glowing or flashing?
 - Eliminate the communication error (see Section 9.3 "LED Signals", page 54).
- ✘ If the AFCI self-test fails the inverter repeats the AFCI self-test until it is successful.
- ✘ If the AFCI self-test continues to fail disconnect the Inverter from all voltage sources (see Section 10).



If the AFCI self-test fails permanently

- Contact the SMA Service Line. Observe Section 16.

In the event of inverter inspection

- Disconnect the Inverter from all voltage sources (see Section 10).

12 Decommissioning

12.1 Disassembling the Inverter

1. Disconnect the inverter from any voltage sources (see Section 10).
2. Disconnect the DC Disconnect from voltage sources (see Section 10.1).
3. Remove the AC output cable from the inverter.
4. If the SPS module is connected, remove the output cable from the inverter.
5. If a data cable is connected, remove the data cable from the inverter.
6. Disconnect the DC cable leading from the inverter to the DC Disconnect and pull it back into the inverter.
7. Place the lower enclosure lid with the 6 screws on the enclosure and tighten them using an Allen key (AF 3) in the order 1 to 6 (torque: 18 in.-lb. (2.0 Nm)).

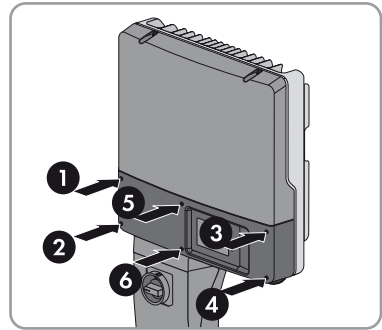

8. **⚠ CAUTION**

Risk of burns due to hot enclosure parts

- Wait 5 minutes for the enclosure to cool down and the residual voltage has been drained.

9. Loosen the screws of the DC Disconnect using an Allen key (AF 4) and remove the DC Disconnect.

10. **⚠ DANGER**

Danger to life due to electric shock when touching the DC cables and DC terminals

High voltages are present in the DC cables and DC terminals.

- Do not touch the DC cables and DC terminals.
- If present, switch off the external DC disconnecting switch or disconnect the PV module plugs.

11. Remove all DC cables from the DC Disconnect.
12. Unscrew all conduits and conduit fittings.

13. Tighten the lid of the DC Disconnect using an Allen key (AF 4) and the corresponding screw and conical spring washer (torque : 44 in-lb. (5 Nm)).
14. If the inverter is protected against theft, open the padlock and remove it.

15. **⚠ CAUTION**

Risk of injury when lifting the inverter, or if it is dropped

The inverter is heavy (see Section 13 "Technical Data", page 81). Risk of injury exists through incorrect lifting and through the inverter falling during transport or when hanging in the wall mounting bracket.

- Lift and transport the inverter horizontally in the mounting position. Use the recessed grips on the sides for this.

16. Lift the inverter off the wall mounting bracket.

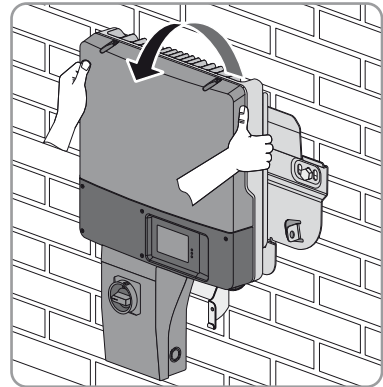

12.2 Packing the Inverter

1. Remove the cable glands from the inverter.
2. Pack the inverter. Use the original packaging or packaging that is suitable for the weight and dimensions of the inverter (see Section 13 "Technical Data", page 81).

12.3 Disposing of the Inverter

- Dispose of the inverter in accordance with the locally applicable disposal regulations for electronic waste.

13 Technical Data

13.1 DC/AC

13.1.1 Sunny Boy 3000TL-US

DC Input

Maximum DC operating power	3,200 W
Maximum system voltage	600 V
Rated MPP tracking voltage range	175 to 480 V
Rated operating voltage	400 V
Minimum operating voltage	125 V
Start voltage, no-load status	150 V
Maximum operating current	18 A
Maximum input current per MPP tracking input	15 A
Maximum short-circuit current per MPP tracking input	19 A
MPP tracking inputs	2
Strings per MPP tracking input	2

AC Output

Rated power at 208 V, or 240 V, 60 Hz	3,000 W
Maximum apparent power	3,050 VA
Nominal AC voltage	208 V / 240 V
AC voltage range at 208 V nominal	183 V to 229 V
AC voltage range at 240 V nominal	211 V to 264 V
Nominal AC current at 208 V	14.5 A
Nominal AC current at 240 V	12.5 A
Maximum output current	15 A
Maximum overcurrent protection	30 A
Total harmonic distortion	≤ 4%
Nominal AC frequency	60 Hz
AC frequency range at 60 Hz nominal	59.3 Hz to 60.5 Hz
Power factor at rated power	1
Connection conductor	2
Output connections	L1, L2, N, PE

Efficiency

Maximum efficiency, η_{\max}	97.1%
CEC efficiency, η_{CEC} at 208 V AC nominal	96.5%
CEC efficiency, η_{CEC} at 240 V AC nominal	96.9%

13.1.2 Sunny Boy 3800TL-US

DC Input

Maximum DC operating power	4,200 W
Maximum system voltage	600 V
Rated MPP tracking voltage range	175 V to 480 V
Rated operating voltage	400 V
Minimum operating voltage	125 V
Start voltage, no-load status	150 V
Maximum operating current	24 A
Maximum input current per MPP tracking input	15 A
Maximum short-circuit current per MPP tracking input	19 A
MPP tracking inputs	2
Strings per MPP tracking input	2

AC Output

Rated power at 208 V, 60 Hz	3,330 W
Rated power at 240 V, 60 Hz	3,840 W
Maximum apparent power at 208 V, 60 Hz	3,330 VA
Maximum apparent power at 240 V, 60 Hz	3,840 VA
Nominal AC voltage	208 V / 240 V
AC voltage range at 208 V nominal	183 V to 229 V
AC voltage range at 240 V nominal	211 V to 264 V
Nominal AC current at 208 V	16 A
Nominal AC current at 240 V	16 A
Maximum output current	16 A
Maximum overcurrent protection	30 A
Total harmonic distortion	$\leq 4\%$
Nominal AC frequency	60 Hz
AC frequency range at 60 Hz nominal	59.3 Hz to 60.5 Hz
Power factor at rated power	1

Connection conductor	2
Output connections	L1, L2, N, PE

Efficiency

Maximum efficiency, η_{\max}	97.2%
CEC efficiency, η_{CEC} at 208 V AC nominal	96.6%
CEC efficiency, η_{CEC} at 240 V AC nominal	97.0%

13.1.3 Sunny Boy 4000TL-US

DC Input

Maximum DC operating power	4,200 W
Maximum system voltage	600 V
Rated MPP tracking voltage range	175 V to 480 V
Rated operating voltage	400 V
Minimum operating voltage	125 V
Start voltage, no-load status	150 V
Maximum operating current	24 A
Maximum input current per MPP tracking input	15 A
Maximum short-circuit current per MPP tracking input	19 A
MPP tracking inputs	2
Strings per MPP tracking input	2

AC Output

Rated power at 208 V, or 240 V, 60 Hz	4,000 W
Maximum apparent power	4,050 VA
Nominal AC voltage	208 V / 240 V
AC voltage range at 208 V nominal	183 V to 229 V
AC voltage range at 240 V nominal	211 V to 264 V
Nominal AC current at 208 V	19.5 A
Nominal AC current at 240 V	16.7 A
Maximum output current	20 A
Maximum overcurrent protection	30 A
Total harmonic distortion	$\leq 4\%$
Nominal AC frequency	60 Hz
AC frequency range at 60 Hz nominal	59.3 Hz to 60.5 Hz

Power factor at rated power	1
Connection conductor	2
Output connections	L1, L2, N, PE

Efficiency

Maximum efficiency, η_{max}	97.2%
CEC efficiency, η_{CEC} at 208 V AC nominal	96.6%
CEC efficiency, η_{CEC} at 240 V AC nominal	97.0%

13.1.4 Sunny Boy 5000TL-US

DC Input

Maximum DC operating power	5,300 W
Maximum system voltage	600 V
Rated MPP tracking voltage range	175 V to 480 V
Rated operating voltage	400 V
Minimum operating voltage	125 V
Start voltage, no-load status	150 V
Maximum operating current	30 A
Maximum input current per MPP tracking input	15 A
Maximum short-circuit current per MPP tracking input	19 A
MPP tracking inputs	2
Strings per MPP tracking input	2

AC Output

Rated power at 208 V, 60 Hz	4,550 W
Rated power at 240 V, 60 Hz	5,000 W
Maximum apparent power at 208 V, 60 Hz	4,550 VA
Maximum apparent power at 240 V, 60 Hz	5,050 VA
Nominal AC voltage	208 V / 240 V
AC voltage range at 208 V nominal	183 V to 229 V
AC voltage range at 240 V nominal	211 V to 264 V
Nominal AC current at 208 V	22 A
Nominal AC current at 240 V	21 A
Maximum output current	22 A
Maximum overcurrent protection	30 A

Total harmonic distortion	≤ 4%
Nominal AC frequency	60 Hz
AC frequency range at 60 Hz nominal	59.3 Hz to 60.5 Hz
Power factor at rated power	1
Connection conductor	2
Output connections	L1, L2, N, PE

Efficiency

Maximum efficiency, η_{\max}	97.0%
CEC efficiency, η_{CEC} at 208 V AC nominal	96.5%
CEC efficiency, η_{CEC} at 240 V AC nominal	96.9%

13.1.5 Sunny Boy 6000TL-US

DC Input

Maximum DC operating power	6,300 W
Maximum system voltage	600 V
Rated MPP tracking voltage range	210 V to 480 V
Rated operating voltage	400 V
Minimum operating voltage	125 V
Start voltage, no-load status	150 V
Maximum operating current	30 A
Maximum input current per MPP tracking input	15 A
Maximum short-circuit current per MPP tracking input	19 A
MPP tracking inputs	2
Strings per MPP tracking input	2

AC Output

Rated power at 208 V, 60 Hz	5,200 W
Rated power at 240 V, 60 Hz	6,000 W
Maximum apparent power at 208 V, 60 Hz	5,300 VA
Maximum apparent power at 240 V, 60 Hz	6,100 VA
Nominal AC voltage	208 V / 240 V
AC voltage range at 208 V nominal	183 V to 229 V
AC voltage range at 240 V nominal	211 V to 264 V
Nominal AC current at 208 V	25 A

Nominal AC current at 240 V	25 A
Maximum output current	25,2 A
Maximum overcurrent protection	40 A
Total harmonic distortion	≤ 4%
Nominal AC frequency	60 Hz
AC frequency range at 60 Hz nominal	59.3 Hz to 60.5 Hz
Power factor at rated power	1
Connection conductor	2
Output connections	L1, L2, N, PE

Efficiency

Maximum efficiency, η_{max}	97.0%*
CEC efficiency, η_{CEC} at 208 V AC nominal	96.5%*
CEC efficiency, η_{CEC} at 240 V AC nominal	96.9%*

* preliminary

13.2 Protective Devices

DC reverse-polarity protection	Short-circuit diode
Input-side disconnection device	DC Disconnect
DC overvoltage protection	Varistors
AC short-circuit current capability	Current control
Grid monitoring	SMA Grid Guard X
Ground-fault monitoring	Insulation monitoring: $R_{iso} \geq 600 \text{ k}\Omega$
All-pole sensitive residual-current monitoring unit	Present
DC arc-fault circuit interrupter	DC AFCI

13.3 General Data

Width x height x depth, inverter	19 ⁵ / ₁₆ in. x 20 ¹ / ₂ in. x 7 ⁵ / ₁₆ in. (490 mm x 519 mm x 185 mm)
Width x height x depth, DC Disconnect	7 ¹³ / ₃₂ in. x 11 ⁴⁵ / ₆₄ in. x 7 ¹ / ₂ in. (187 mm x 297 mm x 190 mm)
Weight inverter	52.9 lb (24 kg)
Weight DC Disconnect	4.4 lb (2 kg)
Length x width x height of the inverter packaging	24 ⁵ / ₁₆ in. x 23 ¹ / ₂ in. x 10 ¹ / ₂ in. (617 mm x 597 mm x 266 mm)
Length x width x height of the DC Disconnect packaging	14 ³⁹ / ₆₄ in. x 9 ¹³ / ₃₂ in. x 11 in. (370 mm x 240 mm x 280 mm)
Transport weight inverter	59.5 lb (27 kg)
Transport weight DC Disconnect	6.6 lb (3 kg)
Climatic category according to IEC 60721-3-4	4K4H
Operating temperature range	- 40 °F to +140 °F (- 40 °C to +60 °C)
Maximum permissible value for relative humidity, non-condensing	100%
Maximum operating altitude above Mean Sea Level	3,000 m
Noise emission, typical	≤ 25 dB(A)
Power loss in night mode	< 1 W
Topology	Transformerless
Cooling concept	Convection
Fan connection	designed for safe disconnection in accordance with DIN EN 50178:1998-04 (until 2013 replaced by DIN EN 62109-1)
Electronics degree of protection	NEMA 3R
Protection class	I
Oversvoltage category	IV
Approvals, as at March 2013	UL 1741, UL 1699B, IEEE 929-2000, IEEE 1547, Canadian Electrical Code® CSA C22.2 NO. 107.1-01
Grid configurations	208/120 V Wye, 120/240 V Split-phase

13.4 DC Disconnect

Maximum rated switching current per string input	20 A
Maximum switching voltage	600 V
Degree of protection	NEMA 3R

13.5 Climatic Conditions

According to IEC 60721-3-4, installation type C, class 4K4H

Extended temperature range	- 40°F to +140°F (- 40°C to +60°C)
Extended humidity range	0% to 100%
Extended air pressure range	79.5 kPa to 106 kPa

According to IEC 60721-3-2, transport type E, class 2K3

Temperature range	- 40°F to +140°F (- 40°C to +60°C)
-------------------	-------------------------------------

13.6 Features

DC connection	Screw terminal
AC connection	Spring-cage terminal
Display	LC graphic display
RS485, galvanically isolated	optional
Speedwire with Webconnect function	optional
Fan retrofit kit	optional
SPS module	optional*

* only with a corresponding order, no retrofitting possible

13.7 Torques

Lower inverter lid screws	18 in.-lbs. (2.0 Nm)
DC Disconnect lid screw	44 in.-lbs. (5.0 Nm)
Screws of the DC Disconnect retainer on the inverter wall mounting bracket	44 in.-lbs. (5.0 Nm)
Screws of the DC Disconnect on the retainer	44 in.-lbs. (5.0 Nm)
Ground connection in the inverter	53 in.-lbs. (6.0 Nm)
Grounding screw in the grounding bracket of the DC Disconnect on the inverter	53 in.-lbs. (6.0 Nm)
DC grounding terminal in the DC disconnect	15 in.-lbs. (1.7 Nm)
DC terminals for the PV modules	15 in.-lbs. (1.7 Nm)
DC terminal for the inverter DC cable in the DC Disconnect	15 in.-lbs. (1.7 Nm)

13.8 Data Storage Capacity

Energy yields over the course of the day	63 days
Daily yields	30 years
Event messages for users	250 events
Event messages for installers	250 events

14 Accessories

You will find relevant accessories and spare parts for your product in the following overview. If required, these can be ordered from SMA or your distributor.

Description	Brief description	SMA order number
DC replacement varistors	Set with 4 varistors incl. insertion tool	SB-VDC-US02
Fan retrofit kit	Retrofit kit for connecting a fan	FANKIT02-10
RS485 module	Module for communication via RS485	DM-485CB-US-10
Speedwire module with Webconnect function	Module for communication with Sunny Portal via Webconnect	SWDM-10

15 Compliance Information

FCC Compliance

This device complies with Part 15 of the FCC Rules.

Operation is subject to the following conditions:

1. This device may not cause harmful interference, and
2. This device must accept any interference received, including interference that may cause undesired operation.

NOTE: This equipment has been tested and found to comply with the limits for a Class B digital device, pursuant to Part 15 of the FCC Rules. These limits are designed to provide reasonable protection against harmful interference in a residential installation. This equipment generates, uses, and can radiate radio frequency energy and if not installed and used in accordance with the instructions, may cause harmful interference to radio communications. However, there is no guarantee that interference will not occur in a particular installation. If this equipment does cause harmful interference to radio or television reception, which can be determined by turning the equipment off and on, the user is encouraged to try to correct the interference by one or more of the following measures:

- Reorient or relocate the receiving antenna.
- Increase the separation between the equipment and the receiver.
- Connect the equipment into an outlet on a circuit different from that to which the receiver is connected.
- Consult the dealer or an experienced radio/TV technician for help.
- The user is cautioned that changes or modifications not expressly approved by SMA America, Inc. could void the user's authority to operate this equipment.

IC Compliance

This device complies with Industry of Canada licence-exempt RSS standard(s).

This Class B digital apparatus complies with Canadian ICES-003.

Cet appareil numérique de la classe B est conforme à la norme NMB-003 du Canada.

Operation is subject to the following two conditions:

- This device may not cause interference, and
- This device must accept any interference, including interferences that may cause undesired operation of the device.

16 Contact

If you have technical problems concerning our products, contact the SMA Service Line. We need the following data in order to provide you with the necessary assistance:

- Inverter device type
- Inverter serial number
- Inverter firmware version
- Special country-specific settings of the inverter (if applicable)
- Type and number of PV modules connected
- Mounting location and mounting altitude of the inverter
- Three-digit or four-digit event number and display message of the inverter
- Optional equipment, e.g., communication products

United States/ Estados Unidos	SMA America, LLC Rocklin, CA	+1 877-MY-SMATech (+1 877-697-6283)* +1 916 625-0870**
Canada/ Canadá	SMA Canada, Inc. Toronto	+1 877-MY-SMATech (+1 877-697-6283)***

* toll free for USA, Canada and Puerto Rico / Llamada gratuita en EE. UU., Canadá y Puerto Rico

** international / internacional

*** toll free for Canada / gratuit pour le Canada

SMA Solar Technology

www.SMA-Solar.com

SMA America, LLC

www.SMA-America.com



YOUR SMA DISTRIBUTOR
SOLARIS
720-474-6050
www.solaris-shop.com

